

# KOBELCO

SK140SRD-7 / SK210D-11E

Performance  Design

Dismantling machine  
**SK140SRD SK210D**



Complies with the EU Stage V  
exhaust emission regulation

*Built for Perfectionists™*

# Performance Design

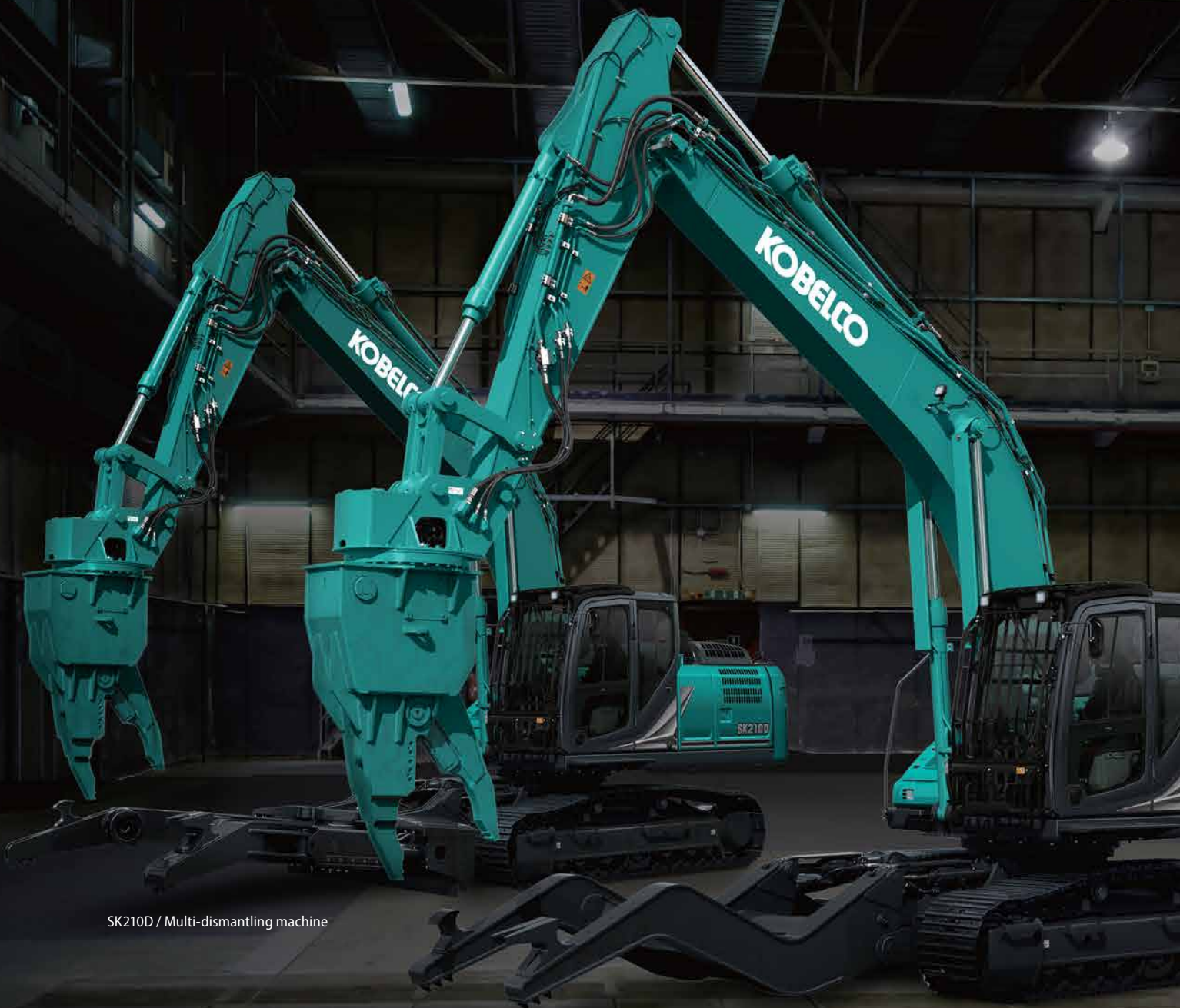

SK210D / Multi-dismantling machine

SK210D / Car-dismantling machine

**PERFORMANCE** — Improved power and speed, and the thorough pursuit of efficiency and productivity.

**DESIGN** — An operator-first design with no compromises on ease of use and comfort.

By combining these two principles, KOBELCO's new values have been achieved in the SK140SRD & SK210D, the new dismantling machine which has been released with specialized equipment for dismantling, and appears in the lineup of 13-ton or 20-ton class machines.

KOBELCO aims to be a unique, unforgettable existence from the first experience, and continues to take on new challenges.

---

## SK140SRD

Multi-dismantling machine

---

## SK210D

Multi-dismantling machine  
Car-dismantling machine

---



SK140SRD / Multi-dismantling machine

# Variety and Individuality. All Parts of the Body are

## Dedicated nibbler

Multi dismantling nibbler : Lightweight design allows fine operation  
 Car dismantling nibbler : Efficient car dismantling work is possible



Multi-dismantling nibbler KHE750PR-2 (for SK140SRD)



Multi-dismantling nibbler KVE720PR (for SK210D)



Car-dismantling nibbler KV800PR (for SK210D)

## Clamp arm

Can secure large objects, and pinch small objects. Using the equipment included with the arm allows work to be performed efficiently.



Multi-dismantling machine (4 way)



Car-dismantling machine (2 way)



SK210D

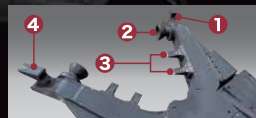

SK140SRD



**Anchor**  
Used to bend long objects



**Grip**  
Rotates objects forwards or backwards that are grabbed by the clamp



**Teeth**  
Allows objects to be crushed or cut



**Puller**  
Shaped for convenient attachment to a harness

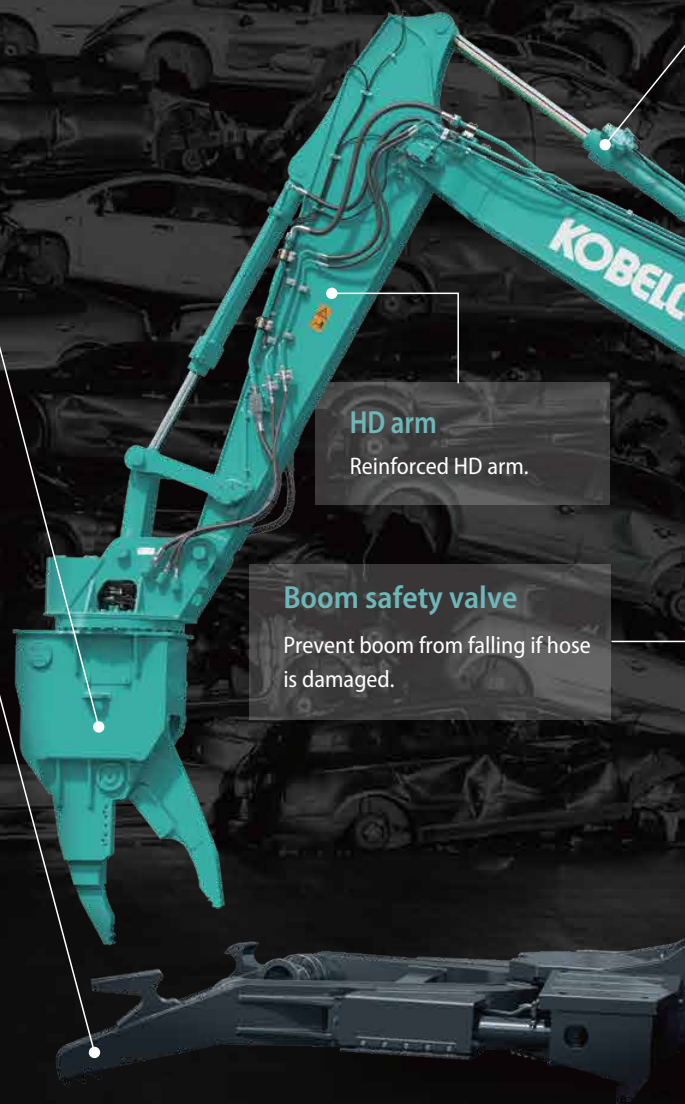

**HD arm**  
Reinforced HD arm.

**Boom safety valve**  
Prevent boom from falling if hose is damaged.

## Dismantling process flow chart

How the dismantling machine works

**1. Collecting fuel, fluids and chlorofluorocarbon gas**  
 Remove fluids such as fuel, anti freeze, oils and chlorofluorocarbon gas

**2. Parts collection**  
 Efficiently collect reusable parts

**3. Collecting undercarriage parts and engines**  
 The car is turned to safely collect engine, exhaust system and suspension parts

# Specialized for dismantling Work.



Photo : SK210D Multi-dismantling machine

## Arm safety valve

Prevent arm from falling if hose is damaged.

## Reinforced arm cylinder [only SK210D]

Reinforced to withstand high loads.

## HD boom

Dedicated reinforced HD boom.

## Boom cylinder guard

Prevents collisions from damaging the cylinder.

## Boom foot cover / Center cover [only SK140SRD]

Prevent metal fragments from entering the cab.

## Cab for dismantling machine

The large skylight glass is equipped with a top guard.

### <Dedicated equipment>

- Grid type front guard with a holder for work boots
- OPG Level II top guard
- 4-inch armrest
- Air suspension seat
- Cab entry step

## Counterweights

For maintaining the ideal balance.

SK140SRD : Additional weight (+580kg)

SK210D : Heavier weight (TTL 5,490kg)

## 4. Car dismantling process



After pre-processing, the car is sorted into raw components such as ferrous, non-ferrous and plastics



29 Cu

Copper  
63.546

13 Al

Aluminium  
26.982



Harnesses



Engine



Radiator

## 4. Processes after removing parts

Once thoroughly cleaned, the parts become good quality recycled parts



## 5. Volume reduction processes

After treating, the scrap cars are cut up and crushed or pressed into materials that meet industry needs



Blocks of material can then be distributed to smelting plants for recycling



EUROPEAN WAY

To the next level of power and functional aesthetics

### High-output engine, compliant with the latest regulations

The high-performance engine is demonstrated in all operations, and notably allows high-load lifting and pulling to be performed smoothly.

#### Engine output

SK210D

**127 kW / 2,000 min<sup>-1</sup>**

Model : YANMAR 4TN107FTT

SK140SRD

**78.5 kW / 2,000 min<sup>-1</sup>**

Model : ISUZU 4JJ1XDDV A01

ISO 14396 : without fan

### Know everything at a glance: Large 10-inch colour monitor

Incorporates the industry's biggest large-format monitor. The information you need is easy to see and operating the menus is simple. The large camera image means you can quickly confirm safety conditions.



### Exquisitely designed LED backlighting

Switches and dials are equipped with LED backlighting. In addition to increasing recognizability at night, the lighting gives the interior a classy aura.

### Simple operation with the jog dial

Several operations combined in the jog dial. Watch the screen associated with the dial, and then turn, select, push, and go. Simple!

### New console tilt makes getting in and out easy

The design of the left console with safety lever takes getting in and out into consideration with a large-angle recoil.



### Automatic lighting LED door light

A bright LED door light turns on in conjunction with opening the door and turning off the key.

## Comfort

Renewed usability and comfort, improved work efficiency.



### Air suspension seat

An air suspension seat is equipped as standard, with excellent shock absorption to prevent fatigue even when sitting for a long time. It includes a wide four-inch arm rest that allows you to take a comfortable position and a seat heater for comfortable operation even in winter season.

### Equipment that improves time spent in the cab



Smartphone holder



12 V Power supply / USB port



DAB+ Radio  
(FM/AM & AUX & USB & Bluetooth\*  
& Hands Free Telephone)



Sun screen

## Operability

Stress-free work performance.

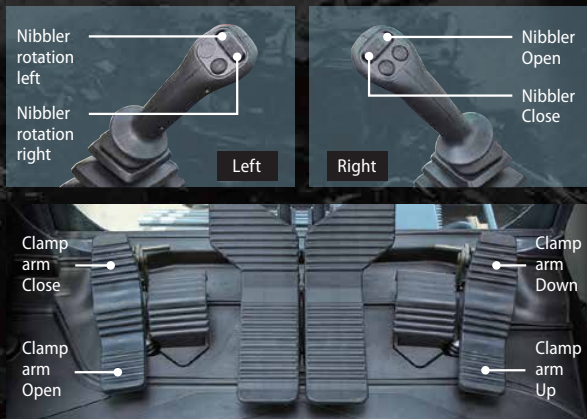

### PHC lever for simultaneous operations

The PHC (Proportional hand control) lever is with a slide switch on the left and right grips for opening/closing and rotating the nibbler. Fine movements can be easily performed, and clamp-arm movements can be performed simultaneously in combination with the foot pedal for increased work efficiency.

### Superior stability

The SK140SRD now has a 580kg add-on weight, and the SK210D has an increased 1,670kg (TTL 5,490kg) counterweight, all equipped as standard.

The increased stability reduces sway during dismantling, affording even more efficient operation.



SK140SRD



SK210D

## Safety

Functions and equipment designed for the protection of operators and workers.



Cab Interference Warning



Boom angle sensor

Arm angle sensor

Bucket angle sensor

### Cab for dismantling that includes a top guard

A new cab with a wiper and a large, glass skylight for a wide upper view. Standard equipment consists of a grid type guard on the front, which does not obstruct the operator's field of vision, and a top guard with a gas damper. The front and right-side windows have shatterproof film applied. This protects the operator from scattering metal fragments.



### Cab-interference prevention system that prevents collisions with the nibbler

The cab interference prevention system is provided as standard equipment to prevent the nibbler from contacting the cab during operation. Precise detection of the position and orientation of the nibbler minimizes the interference warning range to enable a larger effective working area. Since the nibbler tool is restricted from coming into contact with the cab, the operator is able to work more productively and with more focus on the dismantling process.

### A front-side polycarbonate guard is available as an option

This high-strength guard can block even small fragments. It has scratch resistance to maintain a clear view.



\* Cannot be attached to the optional wire mesh type front guard.

Photo: SK140SRD  
Multi-dismantling machine

## Visibility

Work visibility for quickly confirming safety.

### LED work light to keep visibility in low light or at night

Equipped with five high brightness LED work lights. The lights keep the work area bright even in low light or at night. Work area safety can also be quickly confirmed.



Boom (2 lights)

Cab top front (2 lights)



Upper frame (1 light)

Rear counterweight (2 lights)

Photo: SK140SRD



Right camera

Rear camera

Eagle-Eye View

### Right, left and rear view cameras / Eagle-Eye View

Cameras are equipped on the rear, right, and left sides of the base machine. Camera image is easily visible on the large 10-inch monitor. The blind spots behind and to the right can be checked in a glance from the operator's seat to confirm safety. The operator can choose how to display the camera image.

## iNDR [only SK140SRD]

Stand-out KOBELCO-exclusive technology on dismantling work sites.

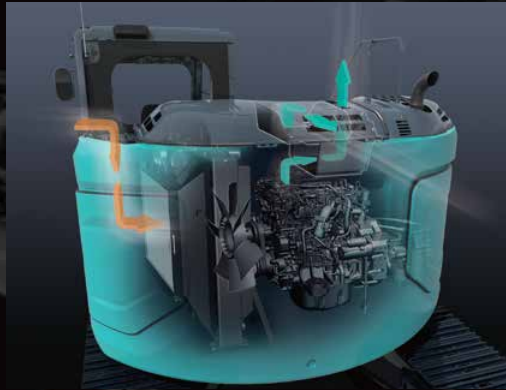

iNDR absorbs sound energy to minimize noise by making a path of air, which cools down the engine. The SK140SRD is equipped with a selective catalytic reduction (SCR) unit, which required a new design with two offset ducts on top. This allows ample space to absorb engine noise.

### Eliminating dust maintains cooling system performance

The high-density 30-mesh\* filters dust in the intake air. This prevents clogging of the cooling system and the air cleaner, which maintains peak performance. The waveform filter allows air through the tops of the waves while collecting dust at the bottom, ensuring a smooth airflow.

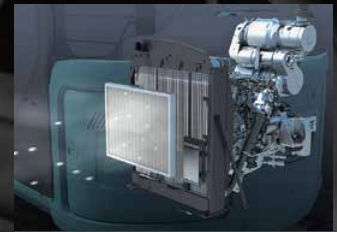

Blocking out dust

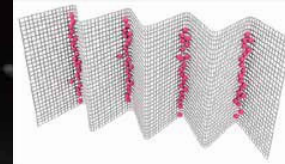

How the filter catches dust

\* "30-mesh" means that there are 30 holes formed by horizontal and vertical wires in every square inch of filter.

## KOBELCO MONITORING EXCAVATOR SYSTEM



### Total support for machines with network speed and accuracy

KOMEXS is a satellite-based system for receiving machine information. Manage your machines anywhere in the world using the Internet. Location, workload and diagnostic data aid business operations.

#### Direct access to operational status

##### Location data

Accurate location data can be obtained even from sites where communications are difficult.

##### Operating hours

A comparison of operating times of machines at multiple locations shows which locations are busier and more profitable. Operating hours on site can be accurately recorded, for running time calculations needed for rental machines, etc.

##### Fuel consumption data

Data on fuel consumption and idling times can be used to indicate improvements in fuel consumption.

##### Graph of work content

The graph shows how working hours are divided among different operating categories, including digging, idling, traveling, and optional operations (N&B).

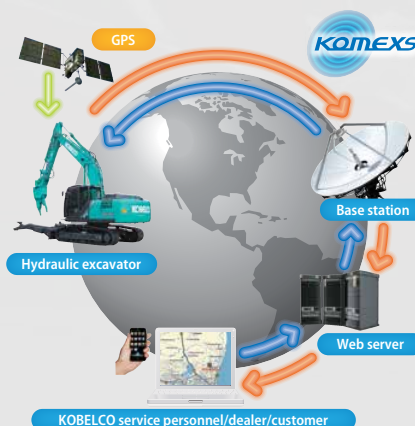

#### Maintenance data and warning alerts

##### Machine maintenance data

Provides maintenance status of separate machines operating at multiple sites. Maintenance data is also relayed to KOBELCO service personnel, for more efficient planning of periodic servicing.

#### Security system

##### Engine start alarm

Sends a notification if the engine is started outside of pre-defined hours.

##### Area alarm

Sends a notification if the machine leaves a pre-defined area.

## Reliability

A multi-dimensional approach for improved reliability and durability.

### HD boom for dismantling

The boom was developed specially. Thick plates are used in each part.



#### HD boom

The sections highlighted in yellow indicate the parts with a dedicated design.

### Dedicated frame for dismantling

Due to the heavy counterweight and clamp arm of this machine, the swing area is redesigned and strengthened for longevity.

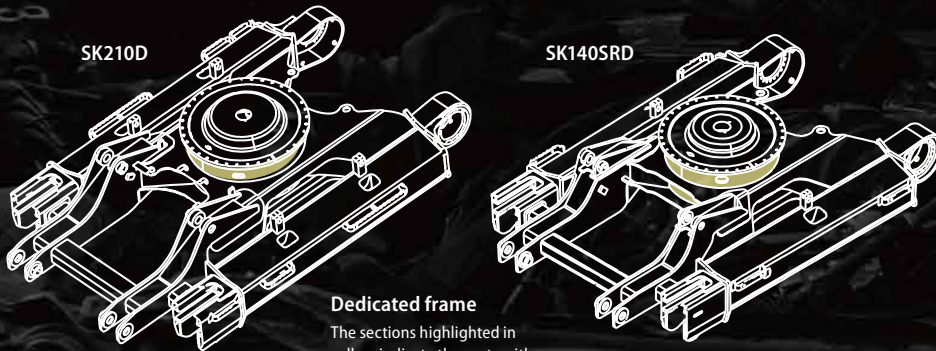

#### Dedicated frame

The sections highlighted in yellow indicate the parts with additional reinforcing.

### Damage - resistant center cover for the clamp arm [only Multi-dismantling machine]

The strength was improved by using a thick plate and changing the shape of the center cover that protects the opening/closing mechanism for the clamp arm.



Photo : SK140SRD Multi-dismantling machine

### Equipment - center cover / boom foot cover [only SK140SRD]

Stops metal fragments from entering the machine from the foot of the boom and prevents the occurrence of hydraulic issues.



Center cover



Boom foot cover



## Equipment

Equipment designed specifically for dismantling.



### Reinforced upper frame under cover guards

6mm-thick steel plate cover protects devices in the base machine.



### Lower frame guard

9mm-thick steel plate cover protects travel-system hydraulic circuits.



### Boom cylinder guard

A steel-plate guard is equipped to protect the boom cylinder rod from scattering-metal fragments.



### Reinforced arm cylinder [only SK210D]

Heavy duty arm cylinder made specially for dismantling application.



### Bucket cylinder rod pin [only SK210D]

The new large-diameter rod pin provides superior durability.



### Hydraulic oil filter

Glass filtration material with outstanding cleaning ability and durability is used.



### Dustproof fuel tank cap

The fuel cap is lined with rubber to prevent dust from contaminating the fuel tank.



### Safety valve for boom & arm cylinder

Prevents attachment from falling if piping is ruptured.

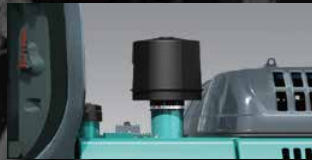

### Pre-aircleaner [only SK210D]

This precleaner has a high dust resistance function that extends the life of the air filter, and is maintenance-free due to the automatic dust discharge function.



### Parallel wipers [only SK210D]

A large wiping area ensures a wide field of view.



### Public address system

Alert workers in the area with clear audio quality.



### Cab entry step

Equipped with a large step to make entering or exiting the driver's seat easy.



### Lower frame step [only SK210D]

An additional step is installed on the side of the crawler frame.



### Refueling pump

Quickly and safely refuel from the ground.



### Work boots tray

This space was added to hold work boots in order to keep the floor of the cab clean.



### Remote fuel drain cock [only SK140SRD]

Allows fuel to be drained without the need for excessive body contortions.



### Removable screens for easy cleaning [only SK210D]

Easily removable screens to prevent material from logging the cooling system.

Photo : SK210D Multi-dismantling machine

## SK140SRD

### Multi-dismantling machine



#### Engine

<b>Model</b>	ISUZU 4JJ1XDDV A01
<b>Type</b>	Four cycle, water cooled, overhead camshaft, vertical in-line, direct injection type, with turbo-charger. (Stage V-compliant engine)
<b>No. of cylinders</b>	4
<b>Bore and stroke</b>	95.4 mm x 104.9 mm
<b>Displacement</b>	2,999 ml
<b>Rated power output</b>	78.5 kW / 2,000 min <sup>-1</sup> (ISO 14396: without fan)
<b>Max. torque</b>	375 N-m / 1,800 min <sup>-1</sup> (ISO 14396 : without fan)



#### Hydraulic system

<b>Pump</b>	
<b>Type</b>	Two variable displacement piston pumps + extra pump + pilot pump
<b>Max. discharge flow</b>	2 x 130 L/min 1 x 59.8, 1 x 20 L/min
<b>Relief valve setting</b>	
<b>Boom, arm and bucket</b>	34.3 MPa
<b>Travel circuit</b>	34.3 MPa
<b>Swing circuit</b>	28.0 MPa
<b>Pilot control circuit</b>	5.0 MPa
<b>Nibbler (Crusher) circuit</b>	Open & Close 24.5 MPa Rotation 20.6 MPa
<b>Clamp arm circuit</b>	Open & Close 24.5 MPa Up & Down 24.5 MPa
<b>Main control valves</b>	12-spool
<b>Oil cooler</b>	Air cooled type



#### Swing system

<b>Swing motor</b>	One fixed displacement piston motor
<b>Brake</b>	Hydraulic
<b>Parking brake</b>	Wet multiple plate
<b>Swing speed</b>	11.0 min <sup>-1</sup>
<b>Swing torque</b>	40.4 kN-m



#### Travel system

<b>Travel motors</b>	Variable displacement axial piston motor x 2 pcs with counterbalance valve
<b>Travel brakes</b>	Hydraulic brake
<b>Parking brakes</b>	Wet multiple plate
<b>Travel shoes</b>	44 each side
<b>Travel speed (high / low)</b>	5.6 / 3.4 km/h
<b>Drawbar pulling force</b>	138 kN (SAE)
<b>Gradeability</b>	70% {35°}



#### Cab & control

<b>Cab</b>	
All-weather, sound-suppressed steel cab mounted on the silicon-sealed viscous mounts and equipped with a heavy, insulated floor mat	
<b>Control</b>	
Two hand levers and two foot pedals for travel	
Two hand levers and two foot pedals for front attachment and swing	
Electric rotary-type engine throttle	
<b>Noise levels</b>	
<b>External</b>	99 dB (A) (2000/14/EC)
<b>Operator</b>	74 dB (A) (ISO 6396)
<b>Vibration levels</b>	
<b>Hand/arm*</b>	≤ 2.5 m/s <sup>2</sup>
<b>Body*</b>	≤ 0.5 m/s <sup>2</sup>

\* For the risk assessment according to 2002/44/EC, refer to ISO/TR 25398: 2006.



#### Boom, arm, bucket & Clamp arm

bore x stroke (mm)

<b>Boom cylinders</b>	100 x 1,092
<b>Arm cylinder</b>	115 x 1,116
<b>Bucket cylinder</b>	100 x 903
<b>Clamp arm up/down cylinders</b>	110 x 220
<b>Clamp arm open/close cylinders</b>	120 x 510



#### Refilling capacities & lubrications

<b>Fuel tank</b>	186 L
<b>Cooling system</b>	17.0 L
<b>Engine oil</b>	17.0 L
<b>Travel reduction gear</b>	2 x 2.1 L
<b>Swing reduction gear</b>	1.65 L
<b>Hydraulic oil tank</b>	89.9 L tank oil level 192 L hydraulic system
<b>DEF / Urea tank</b>	26.0 L



#### Clamp arm ability

<b>Crushing force (clamp arm tooth for rear)</b>	324 kN
<b>Crushing force (clamp arm tooth for front)</b>	216 kN
<b>Clamping force (clamp arm grip)</b>	137 kN

#### Operating weight & ground pressure

<b>Shoe width</b>	500 mm
<b>Ground pressure</b>	64 kPa
<b>Operating weight</b>	20,500 kg (with KHE750PR-2)



#### Front attachment

<b>Model</b>	KHE750PR-2
<b>Weight</b>	970 kg
<b>Shearing force (blade center)</b>	255 kN
<b>Crushing force (tooth-jaw tip)</b>	88.3 kN
<b>Operating pressure</b>	open/close 24.5 MPa rotation 14.2 MPa
<b>Max. RPM</b>	12 min <sup>-1</sup>

Multi-dismantling nibbler KHE750PR-2

Unit : mm

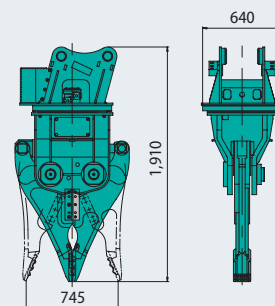

# SK210D

## Multi-dismantling machine / Car-dismantling machine



### Engine

Model	YANMAR 4TN107FTT
Type	Four-stroke, 4 cylinder, water-cooled, direct injection, turbo charged (with intercooler) diesel engine. (Stage V-compliant engine)
No. of cylinders	4
Bore and stroke	107 mm x 127 mm
Displacement	4,567 ml
Rated power output	127 kW / 2,000 min <sup>-1</sup> (ISO 14396: without fan)
Max. torque	805 N-m / 1,500 min <sup>-1</sup> (ISO 14396: without fan)



### Hydraulic system

Pump	
Type	Two variable displacement piston pumps + extra pump + pilot pump
Max. discharge flow	2 x 220 L/min 1 x 50.6, 1 x 20 L/min
Relief valve setting	
Boom, arm and bucket	34.3 MPa
Travel circuit	34.3 MPa
Swing circuit	29.0 MPa
Pilot control circuit	5.0 MPa
Nibbler (Crusher) circuit	Open & Close 29.4 MPa Rotation 20.6 MPa
Clamp arm circuit	Open & Close 29.4 MPa (Multi-dismantling) Up 29.4 MPa / Down 34.3 MPa
Main control valves	8-spool
Oil cooler	Air cooled type



### Swing system

Swing motor	One fixed displacement piston motor
Brake	Hydraulic
Parking brake	Wet multiple plate
Swing speed	12.7 min <sup>-1</sup>
Swing torque	71.5 kN-m



### Travel system

Travel motors	Variable displacement axial piston motor x 2 pcs with Counter balance Valve
Travel brakes	Hydraulic brake
Parking brakes	Wet multiple plate
Travel shoes	46 each side
Travel speed (high / low)	6.0 / 3.6 km/h
Drawbar pulling force	200 kN (SAE)
Gradeability	58% {30°}



### Cab & control

#### Cab

All-weather, sound-suppressed steel cab mounted on the high suspension mounts filled with silicone oil and equipped with a heavy, insulated floor mat

#### Control

Two hand levers and two foot pedals for travel  
Two hand levers and two foot pedals for front attachment and swing  
Electric rotary-type engine throttle

#### Noise levels

External	103 dB (A) (2000/14/EC)
Operator	71 dB (A) (ISO 6396)

#### Vibration levels

Hand/arm*	≤ 2.5 m/s <sup>2</sup>
Body*	≤ 0.5 m/s <sup>2</sup>

\* For the risk assessment according to 2002/44/EC, refer to ISO/TR 25398: 2006.



### Boom, arm, bucket & Clamp arm

bore x stroke (mm)

	Multi-dismantling	Car-dismantling
Boom cylinders	120 x 1,335	
Arm cylinder	135 x 1,558	
Bucket cylinder	120 x 1,080	
Clamp arm up/down cylinders	115 x 320	
Clamp arm open/close cylinders	125 x 590	—



### Refilling capacities & lubrications

Fuel tank	321 L
Cooling system	23 L
Engine oil	20 L
Travel reduction gear	2 x 4.5 L
Swing reduction gear	2.7 L
Hydraulic oil tank	140 L tank oil level
	300 L hydraulic system (Multi-dismantling) 270 L hydraulic system (Car-dismantling)
DEF / Urea tank	83 L



### Clamp arm ability (Multi-dismantling)

Pressing force (clamp arm tooth tip)	62 kN
Crushing force (clamp arm tooth for front)	333 kN
Clamping force (clamp arm grip)	177 kN

### Operating weight & ground pressure

	Multi-dismantling	Car-dismantling
Shoe width	600 mm	
Ground pressure	68 kPa	62 kPa
Operating weight	30,500 kg (with KVE720PR)	27,500 kg (with KVE720PR)



### Front attachment

Model	KVE720PR	KV800PR
Weight	1,900 kg	2,100 kg
Shearing force (blade center)	539 kN	882 kN
Crushing force (tooth-jaw tip)	196 kN	372 kN
Operating pressure	open/close	29.4 MPa
	rotation	14.7 MPa
Max. RPM	10 min <sup>-1</sup>	10 min <sup>-1</sup>

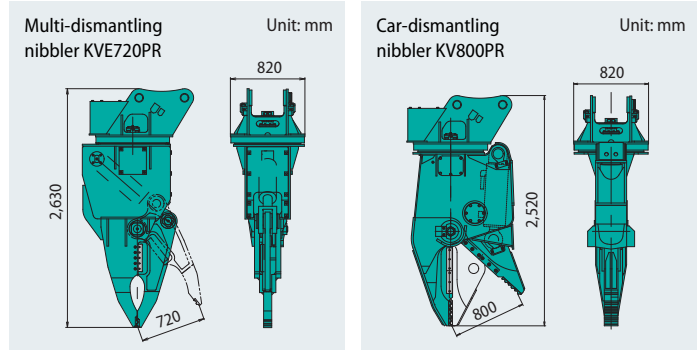

**Dimensions**

**SK140SRD**

**Multi-dismantling machine**

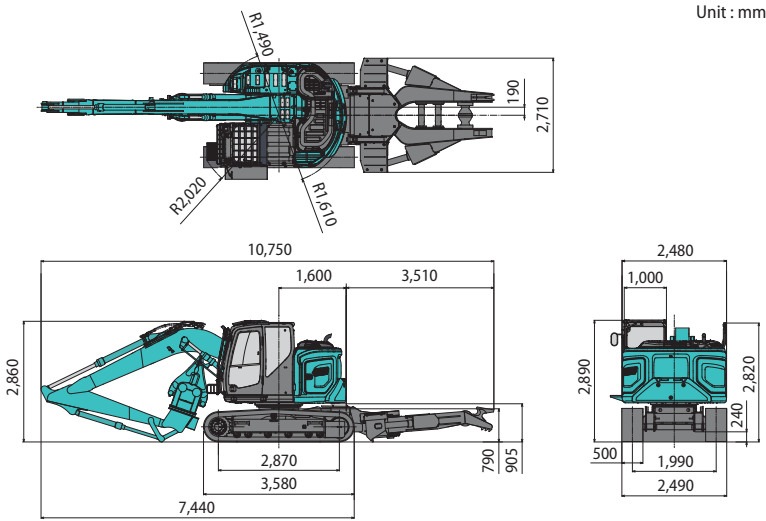

**Working ranges**

**Multi-dismantling machine**

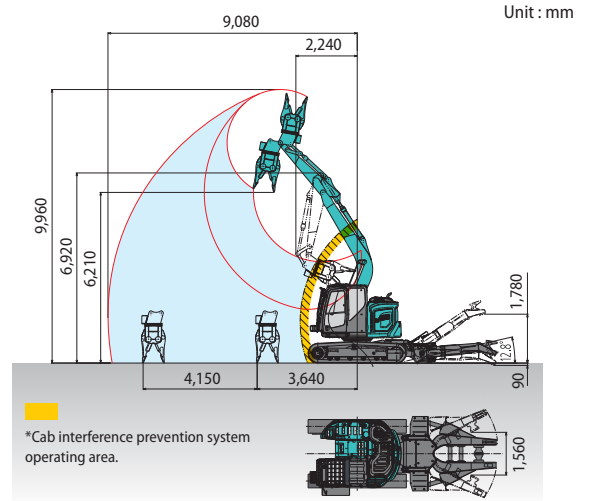

**SK210D**

**Multi-dismantling machine**

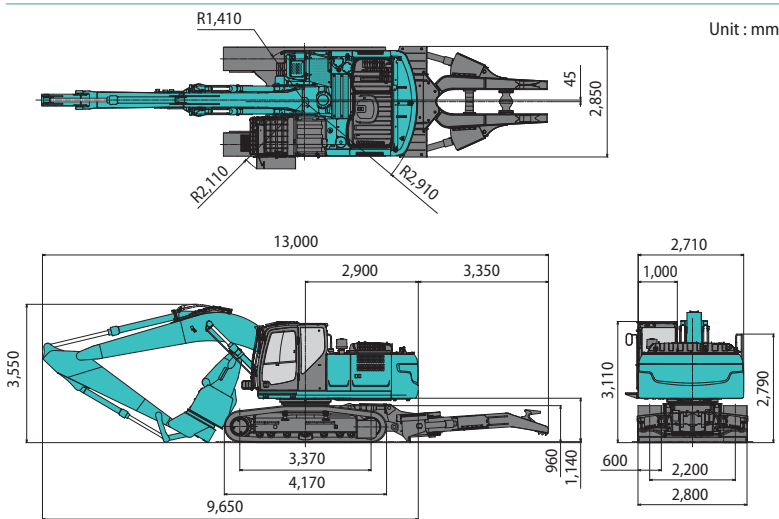

**Multi-dismantling machine**

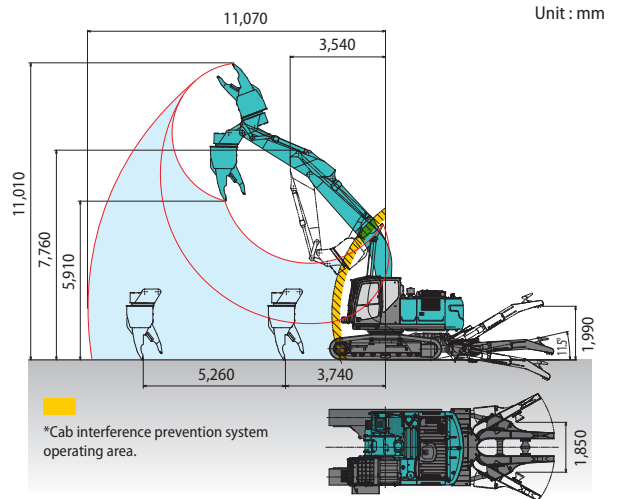

**Car-dismantling machine**

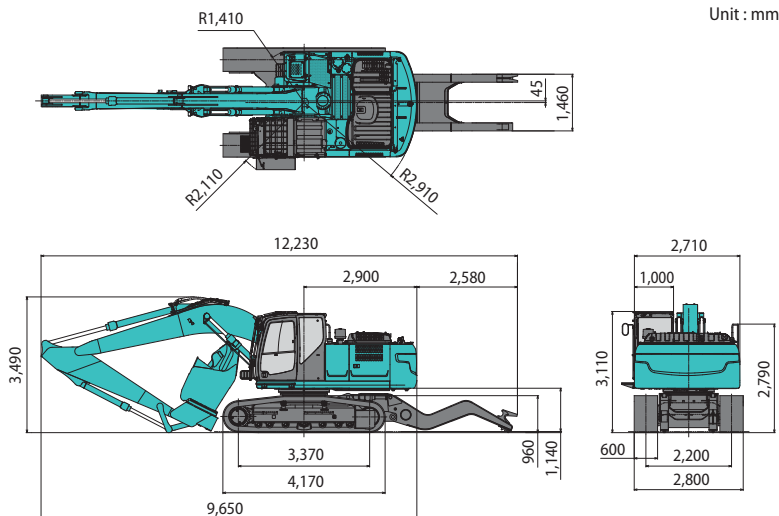

**Car-dismantling machine**

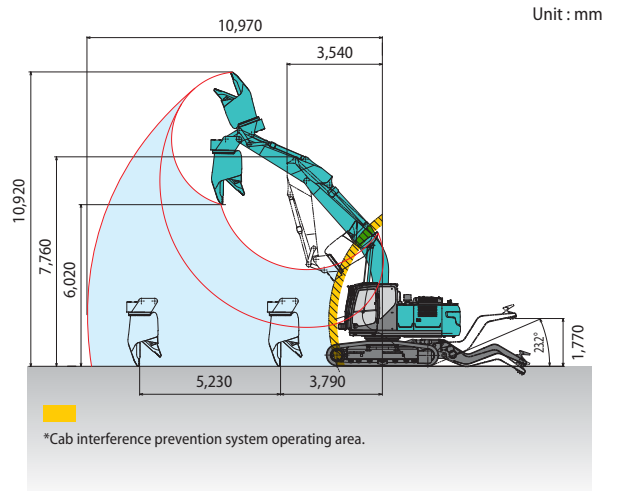

# Standard and Optional Equipment

● =Std ○ =Opt – = N/A

Category	Description	SK140SRD-7	SK210D-11E	
		Multi-dismantling Machine	Car-dismantling Machine	Multi-dismantling Machine
ENGINE	ISUZU 4JJ1XDDV A01 (EU Stage V compliant)	●	–	–
	YANMAR 4TN107FTT (EU Stage V compliant)	–	●	●
	Exhaust DOC DPF SCR system	●	●	●
	Alternator 24 V / 50 A	●	–	–
	Alternator 24 V / 80 A	–	●	●
	Starter motor 24 V / 4 kW	●	–	–
	Starter motor 24 V / 5 kW	–	●	●
	Batteries 2 x 12 V (100 Ah)	●	–	–
	Batteries 2 x 12 V (130 Ah)	–	●	●
	Fan suction type cooling system	●	●	●
	Auto deceleration function	●	●	●
	Auto Idle Stop (AIS)	●	●	●
	Pre-aircleaner	–	●	●
	HYDRAULIC SYSTEM	3 work modes H, S, Eco	●	●
Pressure release function		●	●	●
Auto warm up system		●	●	●
Proportional Hand Control (for Rotation & Nibbler piping)		●	●	●
Hydraulic oil VG32		●	●	●
Hydraulic oil VG46		○	○	○
Hydraulic oil VG68		○	○	○
PIPING	Rotation & Nibbler piping + safety valve (boom & arm cylinder)	●	●	●
CABIN	Air suspension seat with heating	●	●	●
	10-inch colour monitor	●	●	●
	LED door light	●	●	●
	Air-conditioner	●	●	●
	DAB+ radio (FM/AM & AUX & USB & Bluetooth* & hands free telephone)	●	●	●
	Harness for CAB four lights and CAB yellow flasher	●	●	●
	Parallel wiper	–	●	●
	12 V power outlet	●	●	●
	Sun screen	●	●	●
	Cab entry step	●	●	●
	Work boots tray	●	●	●
	Large footrest	●	●	●
LIGHTS	LED work lights: 2 on boom, 1 on upper frame, 2 on rear counterweight, 2 on cab top front	●	●	●
WORKING EQUIPMENT	Standard HD boom (4.68 m)	●	–	–
	Standard HD boom (5.65m)	–	●	●
	Standard HD arm (2.38 m)	●	–	–
	Standard HD arm (2.94 m) with rock guard	–	●	●
	Clamp arm (2 Way)	–	●	–
	Clamp arm (4 Way)	●	–	●
	Nibbler KHE750PR-2	○	–	–
	Nibbler KVE720PR	–	○	○
	Nibbler KV800PR	–	○	○
COUNTERWEIGHT	Additional C/W (+580 kg)	●	–	–
	Heavier C/W (5,490 kg)	–	●	●
UNDERCARRIAGE	500 mm GD shoe	●	–	–
	500 mm flat shoe	○	–	–
	500 mm bolt on rubber pad shoe (with GD shoe)	○	–	–
	600 mm steel shoe	–	●	●
	600 mm flat shoe	–	○	○
	Track guide (one per side)	–	●	●
	Lower frame guard	●	●	●
SAFETY	Engine emergency stop switch	●	●	●
	Pump emergency mode (KPSS release switch)	●	●	●
	Emergency accel dial	●	●	●
	Emergency manual valve for lowering attachment	●	●	●
	Safety valve for boom & arm cylinder	●	●	●
	Cab interference prevention system	●	●	●
	OPG Level II top guard (ISO 10262:1998)	●	●	●
	OPG Level II front guard (ISO 10262:1998)	●	●	●
	Wire mesh type front guard	○	○	○
	Cab front polycarbonate guard	○	○	○
	Eagle-eye view camera (Rear, Right, Left)	●	●	●
	Seatbelt indicator on display	●	●	●
	Travel alarm	○	○	○
	Public address system	●	●	●
	Extended handrail	–	○	○
	Emergency escape hammer	●	●	●
	OTHERS	Refueling pump	●	●
Dustproof fuel tank cap		●	●	●
Harness for engine room light		●	●	●
Boom cylinder guard		●	●	●
Boom foot cover		●	–	–
RAL colour		○	○	○
KOMEXS		●	●	●

Note: Standard and optional equipment may vary. Consult your KOBELCO dealer for specifics.

The air conditioning system on this machine contains fluorinated greenhouse gas HFC-134a (GWP 1430). Quantity of gas 0.8 kg (CO<sub>2</sub> equivalent 1.2 t).

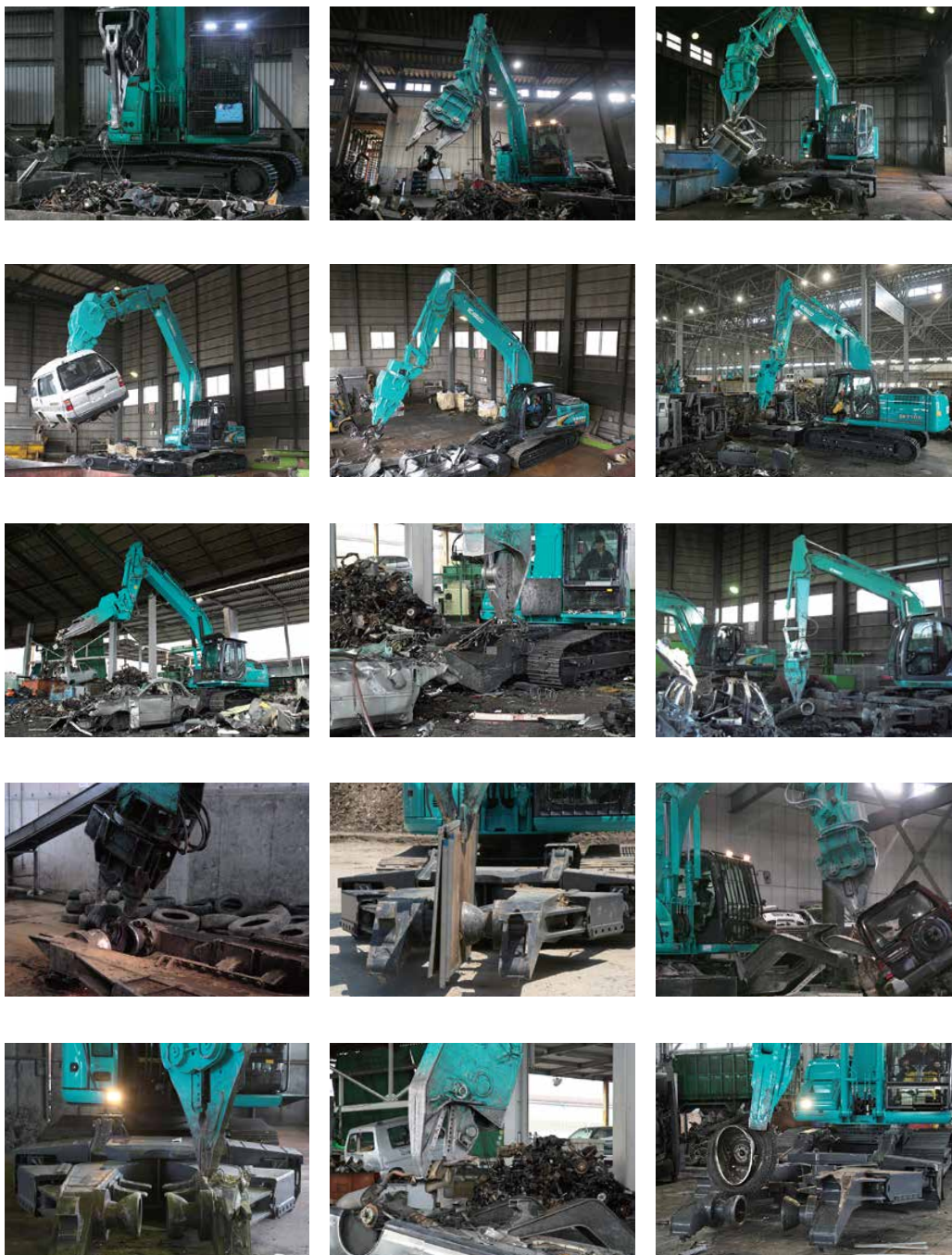

Note: "Bluetooth" is a registered trademark of the Bluetooth SIG Inc.

Note: This catalogue may contain attachments and optional equipment that are not available in your area. And it may contain photographs of machines with specifications that differ from those of machines sold in your areas. Please consult your nearest KOBELCO distributor for those items you require. Due to our policy of continuous product improvements all designs and specifications are subject to change without advance notice.

Copyright by **KOBELCO CONSTRUCTION MACHINERY CO., LTD.** No part of this catalogue may be reproduced in any manner without notice.

**KOBELCO CONSTRUCTION MACHINERY EUROPE B.V.**

Veluwezoom 15  
 1327 AE Almere  
 The Netherlands  
[www.kobelco-europe.com](http://www.kobelco-europe.com)

Enquiries To: