

KOBELCO

SK180LC-11E/SK180N-11E

Performance  Design

SK180_{LC} SK180_N

- Bucket capacity:
0.63 m³
- Engine power:
100 kW / 2,000 min⁻¹
- Operating weight:
19,200 – 21,500 kg



Complies with the EU Stage V
exhaust emission regulation

Built for Perfectionists



Performance Design

SK180LC/SK180N of KOBELCO has realised a completely new value by harmonising PERFORMANCE and DESIGN.

Performance enhancements offer greater efficiency and productivity along with increased power and speed.

Design improvements provide the ultimate in comfort and control.

KOBELCO refuses to compromise, creating machines that meet every challenge.



THE ULTIMATE IN SIMPLE DESIGN

In our pursuit of functional beauty and styling,
we created an all new interior design focused with the operator in mind.

Jog Dial

This dial integrates multiple functions into a single, easy to use interface. Even with gloves on, the operator can make the adjustments they need.

LED Illumination

Dials and buttons are now backlit to provide a bright, clear view in any lighting condition.







UNFORGETTABLE COMFORT

Air suspension seat

A GRAMMER* seat is installed as standard equipment, which achieves excellent shock absorption and superior ride comfort.

*GRAMMER is trademark of GRAMMER AG, registered in Germany and other countries.

Multi Vent Air Conditioner

Cool air is blown from multiple outlets toward the operator's body for more comfortable operation.

Ergonomic Lever Angles

Operators can move levers horizontally without twisting their wrists, reducing fatigue.



New Hydraulic Control

Our newly upgraded hydraulic control system responds to shorter lever strokes than previous models, delivering swifter, more precise movement and improved lever operability.

LED Interior Light

Interior lights turn on and off automatically when the door is open or the ignition is turned to the OFF position. This ensures safe entry and exit in the dark.

Parallel wiper secure a wide field of view



KOBELCO



04:33



SETTING MENU



PICTURE OF CAMERA



CLOCK SETTING



SCREEN BRIGHTNESS



MAINTENANCE



CONSUMPTION



LANGUAGE SELECTION



PRESSURE RELEASE



SAFETY ON FULL DISPLAY

Standard 3 Sides Safety Camera System

Our high-resolution, large display shows right, left and rear side cameras together. Multiple display allows the operator to customize viewing needs to enhance operator awareness and jobsite safety.

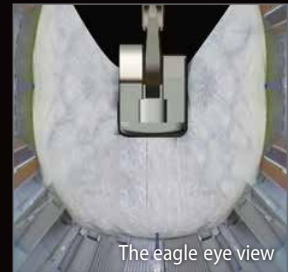
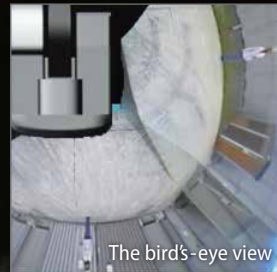
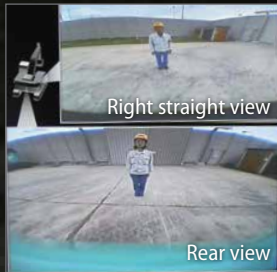

Large 10-Inch Color Monitor

The easy-to-operate menu screen and recognizable icons assist the operator to select the most important information needed to ensure jobsite safety and machine control.



Dial in the Right Information

Simply turn the jog dial to the right or left to select an operational feature, then press the dial to confirm selection.





Independent Travel

Selecting Independent Travel dedicates one hydraulic pump to travel and one to the attachment on a continuous basis, allowing for a smooth and constant movement speed even while swinging or using the boom or attachment. With Independent Travel, safely carrying a large pipe across a job site is a breeze.

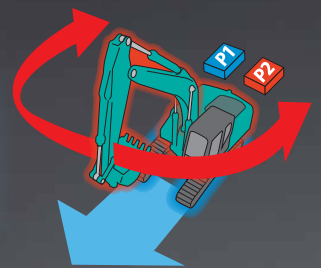

EXPERIENCING A COMPETENT PERFORMANCE

Higher Efficiency, plus a EU Stage V Compliant Engine

The new SK180LC/SK180N is equipped with a Yanmar Stage V compliant engine, which has a higher torque value. Superior balance between engine output and torque contributes to more efficient performance than the previous models. In addition, the DPF replacement interval has been extended.

Model: YANMAR 4TN107FHT

Engine output

100 kW / 2,000 min⁻¹



»» Max. bucket digging force (Arm 2.60 m)

Normal: **114 kN**

With Power Boost: **126 kN**

Lift capacity

8,100 kg

(Reach: 4.50 m Boom: 5.20 m Arm: 2.60 m Bucket: Without
Counterweight: 3,700 kg Shoe: 600 mm <Heavy Lift > At Ground Level)



GREATER MULTI-FUNCTION CAPABILITIES

Attachment mode selection

The auxiliary flow rates for the bucket, breaker, nibbler, and rotating are all now adjustable by the operator through the monitor, allowing you to change tools quickly and easily. Mode settings for other attachments like the tilt rotator can be added or changed.

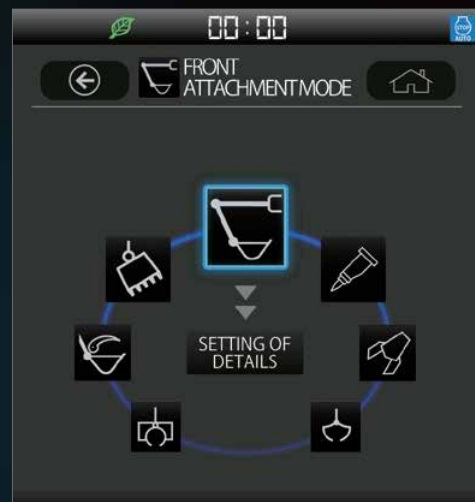

EASY MAINTENANCE



Standard Overhead Top Guard Level II

The standard overhead cab guard can be tilted open with gas damper for easy window cleaning. Meets standard top guard level II requirements. (ISO 10262)



Two-stage air filter



DEF/AdBlue® Tank

The DEF/AdBlue® fill is located inside the locking tool box.



Left side (radiator and cooling system elements)

Laid out for easy access to radiator and cooling system.



Right Side (Ground Level Maintenance)

Hydraulic pump and engine filter compartment.



Engine Oil Filter



Pre-Filter with Integrated Water Separator



Fuel Filter

Note: AdBlue® is a registered trademark of the Verband der Automobilindustrie e.V. (VDA).

DURABILITY YOU CAN TRUST

Enhanced body rigidity for 18-ton class machines

The SK180LC and SK180N machines are widely used in mid-scale construction projects and harsh worksites. The components have been reviewed and improvements have been made to their durability to ensure stable performance in such environments.



Panels and supports

The right and left side panels and rear supports have been thicker to enhance body rigidity.

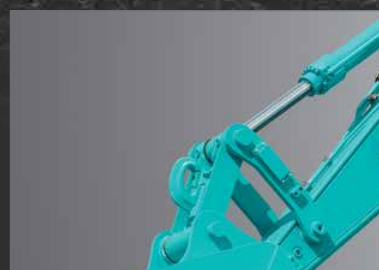

Bucket cylinder rod pin

The increased diameter of the bucket cylinder rod pin contributes to enhanced durability for various types of attachments.

CONVENIENT AND SENSIBLE EQUIPMENT



Engine start password

A password is required when starting the engine for greater security. The initial password must be set at our workshop.



Wiper adjustment function

In addition to the intermittent wiper mode and continuous wiper mode, the one-time wiper mode was added.



Parallel wipers

Sun screen



Console mount

The console-integrated seat allows for comfortable operation.



DAB+ radio (FM/AM & AUX & USB & Bluetooth® & hands-free telephone)



USB port/12V power supply



Smartphone holder

You can use the holder with your smartphone connected to the USB port.



KOBELCO MONITORING EXCAVATOR SYSTEM



Remote Monitoring for Peace of Mind

KOMEXS (Kobelco Monitoring Excavator System) uses satellite communication and internet to relay data, and therefore can be deployed in areas where other forms of communication are difficult. When a hydraulic excavator is fitted with this system, data on the machine's operation, such as operating hours, location, fuel consumption, and maintenance status can be obtained remotely.

Direct Access to Operational Status

Location Data

Accurate location data can be obtained even from sites where communications are difficult.

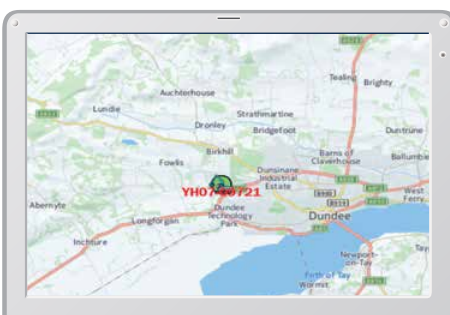

Latest location

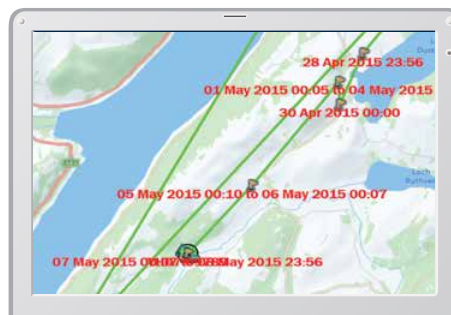

Location records

Period - 11 Apr, 2015		to 10 May, 2015		Search	
Type of Operation	Working Hrs		Ratio		
Total Working Hrs	169 Hrs	100%			
Digging Hrs	72.2 Hrs	43%			
Traveling Hrs	18.3 Hrs	11%			
Idle Hrs	15.9 Hrs	9%			
Opt Att Hrs	62.5 Hrs	37%			
Crane Mode Hrs	0 Hrs	0%			

Work data

Operating Hours

- A comparison of operating times of machines at multiple locations shows which locations are busier and more profitable.
- Operating hours on site can be accurately recorded, for running time calculations needed for rental machines, etc.

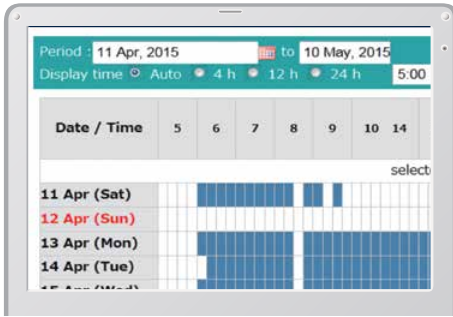

Daily report

Fuel Consumption Data

Data on fuel consumption and idling times can be used to indicate improvements in fuel consumption.

Work mode	Working Hrs	Total Fuel Consumption
H mode	2:06	24.5 L
S mode	0:00	0.0 L
E mode	169:19	1489.7 L
TOTAL	171:25	1514.2 L

Fuel consumption

Graph of Work Content

The graph shows how working hours are divided among different operating categories, including digging, idling, travelling and optional operations.

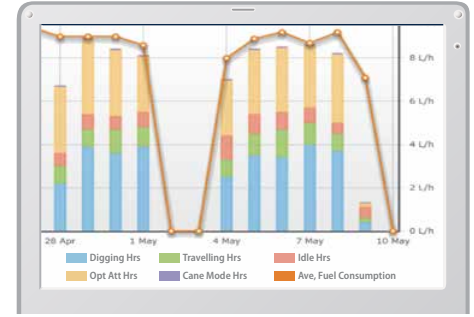

Work status

Maintenance Data and Warning Alerts

Machine Maintenance Data

- Provides maintenance status of separate machines operating at multiple sites.
- Maintenance data is also relayed to KOBELCO service personnel, for more efficient planning of periodic servicing.

Model	Serial No.	Hour Meter	Engine Oil
SK135SRLC-3/SK140SRL	YH07-09721	734 Hr	434
SK135SRLC-3/SK140SRL	YH07-09789	73 Hr	429
SK210LC-9	YQ13-10454	960 Hr	58
SK210LC-9	YQ13-10481	549 Hr	498
SK75SR-	YT08-30374		

Maintenance

Warning Alerts

This system warns an alert if an anomaly is sensed, preventing damage that could result in machine downtime.

Alarm Information Can Be Received through E-mail

Alarm information or maintenance notice can be received through E-mail, using a computer or cell phone.



Alarm messages can be received on mobile device.

Daily/Monthly Reports

Operational data downloaded onto a computer helps in formulating daily and monthly reports.

Security System

Engine Start Alarm

The system can be set an alarm if the machine is operated outside designated time.

Setting Condition
 Setting Condition Change
 Start time 20 : 00
 Release time 07 : 00
 No Working Whole Day
 Mon Tue Wed Thu Fri Sat Sun
 Clear

Engine start alarm outside prescribed work time

Area Alarm

It can be set an alarm if the machine is moved out of its designated area to another location.

Setting Condition
 Around the current (latest) location 1 Km
 Input Latitude and Longitude
 Latitude1
 Longitude1
 Latitude2
 Longitude2
 Map Clear
 Release

Alarm for outside of reset area

Specifications

Engine

Model	YANMAR 4TN107FHT
Type	Four-cycle, water-cooled, direct injection diesel engine, turbo charged, EU Stage V exhaust emission regulation
No. of cylinders	4
Bore and stroke	107 mm × 127 mm
Displacement	4.567 L
Rated power output	95 kW / 2,000 min ⁻¹ (ISO 9249: with fan)
	100 kW / 2,000 min ⁻¹ (ISO 14396: without fan)
Max. torque	588 N-m / 1,500 min ⁻¹ (ISO 9249: with fan)
	602 N-m / 1,500 min ⁻¹ (ISO 14396: without fan)

Hydraulic system

Pump	
Type	Two variable displacement axial piston pumps + extra gear pump + pilot gear pump
Max. discharge flow	2 × 160 L/min, 1 × 41.2 L/min, 1 × 20 L/min
Relief valve setting	
Boom, arm and bucket	34.3 MPa
Power Boost	37.8 MPa
Travel circuit	34.3 MPa
Swing circuit	28.0 MPa
Control circuit	5.0 MPa
Pilot control pump	Gear type
Main control valve	8 - Spool valve
Oil cooler	Air cooled type

Swing system

Swing motor	One fixed displacement piston motor
Brake	Hydraulic; locking automatically when the swing control lever is in the neutral position
Parking brake	Wet multiple plate
Swing speed	12.6 min ⁻¹
Swing torque	52.6 kN-m
Maximum swing gradient (Loaded)*	44 % {24°}

*Value for the least favourable specification

Attachments

Backhoe bucket and combination

Use	Backhoe bucket	
	Normal digging	
Bucket capacity	ISO heaped	m ³
		0.63
Opening width	With side cutter	mm
	Without side cutter	mm
		1,075
		975
Bucket weight		kg
		500
Combination	2.60 m standard arm	⊙
	3.10 m long arm	⊙

⊙ Standard

Travel system

Travel motors	2 x axial-piston, two-step motors	
Travel brakes	Hydraulic brake per motor	
Parking brakes	Oil disc brake per motor	
Travel shoes	SK180LC	49 each side
	SK180N	45 each side
Travel speed	4.5 / 2.7 km/h	
Rated drawbar pull	230 kN (SAE J 1309)	
Gradeability	70% { 35° }	

Cab & control

Cab	
All-weather, sound-suppressed steel cab mounted on the high suspension mounts filled with silicone oil and equipped with a heavy, insulated floor mat.	
Control	
Two hand levers and two foot pedals for travel	
Two hand levers for excavating and swing	
Electric rotary-type engine throttle	
Noise levels	
External	102 dB(A) (2000/14/EC)
Noise levels/Operator	68 dB (A) (ISO 6396:2008)
Vibration levels	
Hand/arm*	≤ 2.5 m/s ²
Body*	≤ 0.5 m/s ²

*For the risk assessment according to 2002/44/EC, refer to ISO/TR 25398: 2006

Cylinders

Boom cylinders	110 mm × 1,156 mm
Arm cylinder	125 mm × 1,285 mm
Bucket cylinder	105 mm × 1,025 mm
Jib cylinder*	135mm × 977mm

*For 2 Piece Boom only

Refilling capacities & lubrications

Fuel tank	280 L
Cooling system	22.7 L
Engine oil	22 L
Travel reduction gear	2 × 4.5 L
Swing reduction gear	1 × 2.7 L
Hydraulic oil tank	122 L tank oil level
	200 L hydraulic system
DEF/Urea tank	33.9 L

Working ranges

Unit: mm

Range	Arm	5.20 m	
		Standard 2.60 m	Long 3.10 m
a- Max. digging reach		8,970	9,490
b- Max. digging reach at ground level		8,800	9,320
c- Max. digging depth		5,990	6,490
d- Max. digging height		9,350	9,770
e- Max. dumping clearance		6,700	7,100
f- Min. dumping clearance		2,650	2,150
g- Max. vertical wall digging depth		5,450	5,950
h- Min. swing radius		2,710	2,740
i- Horizontal digging stroke at ground level		4,490	5,350
j- Digging depth for 2.4 m (8') flat bottom		5,760	6,310
Bucket capacity ISO heaped m ³		0.63	0.63

Digging Force (ISO 6015)

Unit: kN

Arm length	Standard 2.60 m	Long 3.10 m
Bucket digging force	114 126*	114 126*
Arm crowding force	82.3 90.6*	71.7 78.8*

*Power Boost engaged

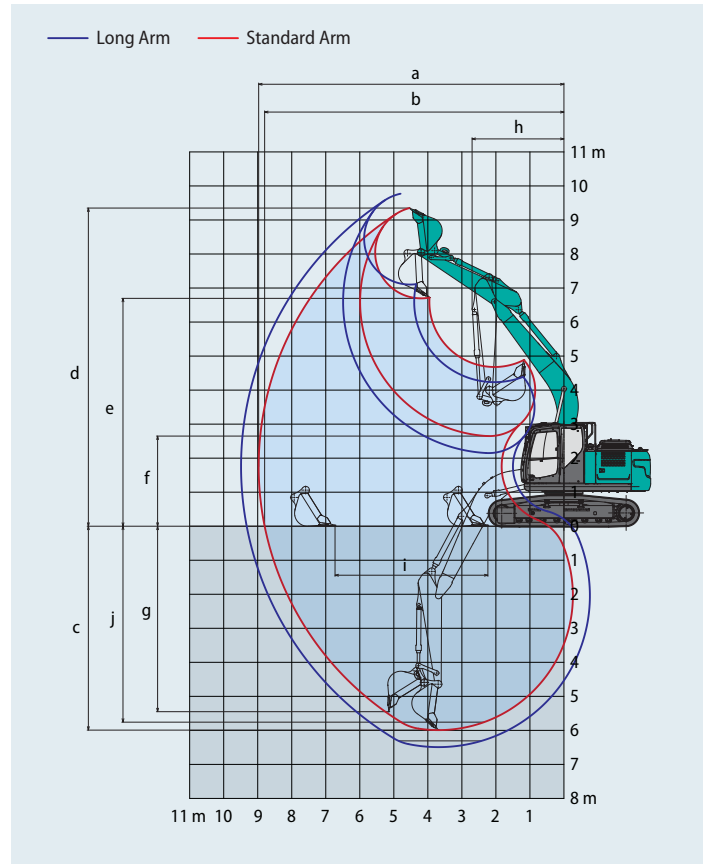

Dimensions

Arm length		Standard 2.60 m	Long 3.10 m
A	Overall length	8,700	8,710
B	Overall height (to top of boom)	2,970	3,100
C	Overall width of crawler	SK180LC	2,800
		SK180N	2,490
D	Overall height (to top of cab)	3,060	
D'	Overall height (to top of handrail)	3,080	
E	Ground clearance of rear end*	1,050	
F	Ground clearance*	440	
G	Tail swing radius	2,550	

Unit: mm

G'	Distance from centre of swing to rear end	2,550	
H	Tumbler distance	SK180LC	3,660
		SK180N	3,280
I	Overall length of crawler	SK180LC	4,450
		SK180N	4,070
J	Track gauge	SK180LC	2,200
		SK180N	1,990
K	Shoe width	SK180LC	600
		SK180N	500
L	Overall width of upperstructure	2,490	

*Without including height of shoe lug

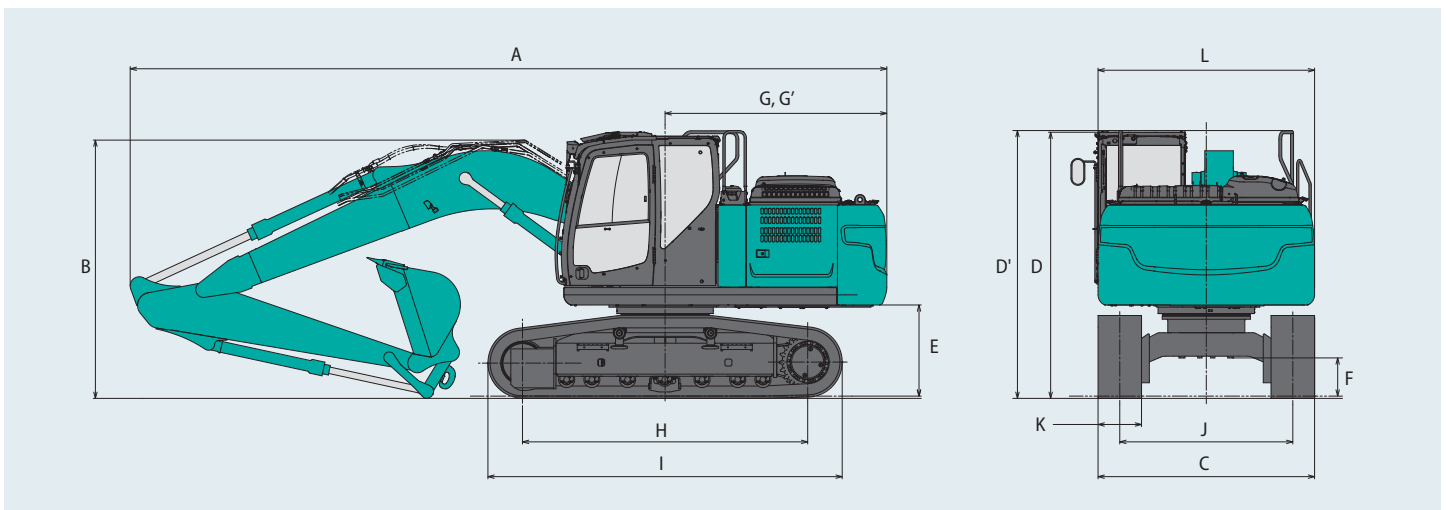

Operating weight & ground pressure

In standard trim, with standard boom, 2.60 m arm, and 0.63 m³ ISO heaped bucket.

Shaped			Triple grouser shoes (even height)				
Shoe width	mm		500	600	700	790	900
Overall width of crawler	SK180LC	mm	—	2,800	2,900	2,990	3,100
	SK180N	mm	2,490	2,590	2,690	2,780	—
Ground pressure	SK180LC	kPa	—	41	36	33	29
	SK180N	kPa	53	45	39	35	—
Operating weight	SK180LC	kg	—	19,900	20,400	20,600	20,900
	SK180N	kg	19,200	19,400	19,800	20,000	—



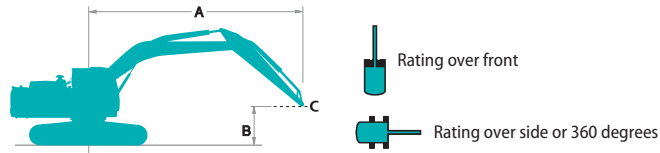









Lift capacities















A - Reach from swing centerline to arm top
 B - Arm top height above/below ground
 C - Lift point
 Relief valve setting: 37.8 MPa

SK180LC		Boom: 5.20 m Arm: 2.60 m Bucket: without Counterweight: 3,700 kg Shoe: 600 mm (Heavy Lift)												
B	A	1.5 m		3.0 m		4.5 m		6.0 m		7.5 m		At max. reach		Radius
7.5 m	kg					*4,320	*4,320					*3,100	*3,100	4.96 m
6.0 m	kg							*3,930	*3,930			*2,770	*2,770	6.32 m
4.5 m	kg					*5,430	*5,430	*4,750	4,190			*2,700	*2,700	7.11 m
3.0 m	kg			*10,260	*10,260	*6,600	6,150	*5,220	4,020	*2,930	2,860	*2,770	*2,770	7.52 m
1.5 m	kg					*7,670	5,750	*5,700	3,840	*3,840	2,790	*2,990	2,730	7.61 m
G.L.	kg			*7,330	*7,330	*8,100	5,520	*5,940	3,710			*3,400	2,790	7.40 m
-1.5 m	kg	*7,010	*7,010	*11,130	10,290	*7,790	5,460	*5,720	3,670			*4,220	3,080	6.86 m
-3.0 m	kg	*11,550	*11,550	*9,160	*9,160	*6,620	5,540					*4,670	3,840	5.89 m
-4.5 m	kg			*5,500	*5,500							*3,960	*3,960	4.21 m

SK180LC		Boom: 5.20 m Arm: 3.10 m Bucket: without Counterweight: 3,700 kg Shoe: 600 mm (Heavy Lift)												
B	A	1.5 m		3.0 m		4.5 m		6.0 m		7.5 m		At max. reach		Radius
7.5 m	kg											*2,260	*2,260	5.73 m
6.0 m	kg							*3,910	*3,910			*2,040	*2,040	6.93 m
4.5 m	kg					*4,870	*4,870	*4,370	4,240	*2,630	*2,630	*1,970	*1,970	7.66 m
3.0 m	kg			*8,960	*8,960	*6,070	*6,070	*4,900	4,050	*3,950	2,860	*2,000	*2,000	8.04 m
1.5 m	kg			*7,790	*7,790	*7,290	5,800	*5,460	3,840	*4,510	2,770	*2,130	*2,130	8.13 m
G.L.	kg			*7,550	*7,550	*7,960	5,500	*5,830	3,680	4,560	2,700	*2,370	*2,370	7.93 m
-1.5 m	kg	*6,000	*6,000	*10,460	10,150	*7,900	5,390	*5,790	3,610			*2,830	2,710	7.43 m
-3.0 m	kg	*9,530	*9,530	*10,060	*10,060	*7,060	5,430	*5,070	3,640			*3,790	3,260	6.55 m
-4.5 m	kg			*7,050	*7,050	*4,910	*4,910					*3,980	*3,980	5.09 m

SK180N		Boom: 5.20 m Arm: 2.60 m Bucket: without Counterweight: 3,700 kg Shoe: 500 mm (Heavy Lift)												
B \ A		1.5 m		3.0 m		4.5 m		6.0 m		7.5 m		At max. reach		Radius
														
7.5 m	kg					*4,320	*4,320					*3,100	*3,100	4.96 m
6.0 m	kg							*3,930	3,760			*2,770	*2,770	6.32 m
4.5 m	kg					*5,430	*5,430	*4,750	3,680			*2,700	*2,700	7.11 m
3.0 m	kg			*10,260	9,740	*6,600	5,350	*5,220	3,520	*2,930	2,490	*2,770	2,480	7.52 m
1.5 m	kg					*7,670	4,960	5,450	3,340	*3,840	2,420	*2,990	2,370	7.61 m
G.L.	kg			*7,330	*7,330	*8,100	4,740	5,310	3,210			*3,400	2,410	7.40 m
-1.5 m	kg	*7,010	*7,010	*11,130	8,650	*7,790	4,690	5,260	3,170			*4,220	2,670	6.86 m
-3.0 m	kg	*11,550	*11,550	*9,160	8,840	*6,620	4,760					*4,670	3,330	5.89 m
-4.5 m	kg			*5,500	*5,500							*3,960	*3,960	4.21 m

SK180N		Boom: 5.20 m Arm: 3.10 m Bucket: without Counterweight: 3,700 kg Shoe: 500 mm (Heavy Lift)												
B \ A		1.5 m		3.0 m		4.5 m		6.0 m		7.5 m		At max. reach		Radius
														
7.5 m	kg											*2,260	*2,260	5.73 m
6.0 m	kg							*3,910	3,820			*2,040	*2,040	6.93 m
4.5 m	kg					*4,870	*4,870	*4,370	3,720	*2,630	2,560	*1,970	*1,970	7.66 m
3.0 m	kg			*8,960	*8,960	*6,070	5,450	*4,900	3,540	*3,950	2,490	*2,000	*2,000	8.04 m
1.5 m	kg			*7,790	*7,790	*7,290	5,010	5,460	3,340	3,890	2,400	*2,130	2,120	8.13 m
G.L.	kg			*7,550	*7,550	*7,960	4,730	5,280	3,180	3,810	2,330	*2,370	2,150	7.93 m
-1.5 m	kg	*6,000	*6,000	*10,460	8,510	*7,900	4,620	5,200	3,110			*2,830	2,340	7.43 m
-3.0 m	kg	*9,530	*9,530	*10,060	8,650	*7,060	4,650	*5,070	3,140			*3,790	2,810	6.55 m
-4.5 m	kg			*7,050	*7,050	*4,910	4,850					*3,980	*3,980	5.09 m

Notes:

1. Do not attempt to lift or hold any load that is greater than these lift capacities at their specified lift point radius and heights. Weight of all accessories must be deducted from the above lift capacities.
2. Lift capacities are based on machine standing on level, firm, and uniform ground. User must make allowance for job conditions such as soft or uneven ground, out of level conditions, side loads, sudden stopping of loads, hazardous conditions, experience of personnel, etc.
3. Arm top defined as lift point.
4. The above lift capacities are in compliance with ISO 10567. They do not exceed 87% of hydraulic lift

capacity or 75% of tipping load. Lift capacities marked with an asterisk (*) are limited by hydraulic capacity rather than tipping load.

5. Operator should be fully acquainted with the Operator's and Maintenance Instructions before operating this machine. Rules for safe operation of equipment should be adhered to at all times.
6. Lift capacities apply to only machine as originally manufactured and normally equipped by KOBELCO CONSTRUCTION MACHINERY CO., LTD.

2 Piece Boom Specifications

Working ranges

Unit: mm

Range	Arm	2 Piece Boom	
		Standard 2.60 m	Long 3.10 m
a- Max. digging reach		8,830	9,350
b- Max. digging reach at ground level		8,660	9,180
c- Max. digging depth		5,600	6,120
d- Max. digging height		10,040	10,520
e- Max. dumping clearance		7,350	7,830
f- Min. dumping clearance		650	150
g- Max. vertical wall digging depth		4,830	5,380
h- Min. swing radius		2,070	2,210
i- Horizontal digging stroke at ground level		6,220	7,230
j- Digging depth for 2.4 m (8') flat bottom		5,480	6,010
Bucket capacity ISO heaped m ³		0.63	0.63

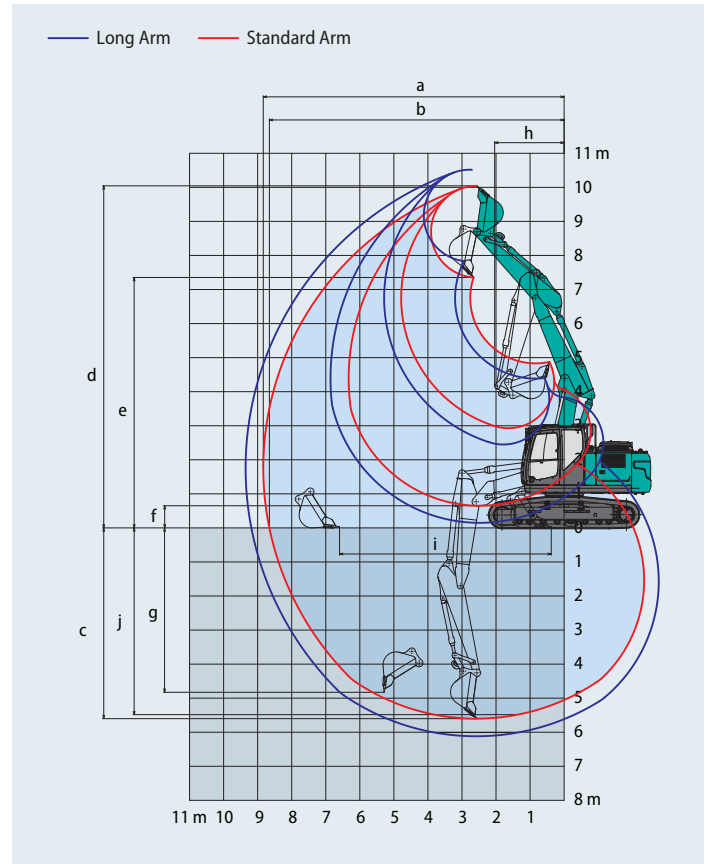

Digging Force (ISO 6015)

Unit: kN

Arm length	Standard 2.60 m	Long 3.10 m
Bucket digging force	114 126*	114 126*
Arm crowding force	82.3 90.6*	71.7 78.8*

*Power Boost engaged.

Dimensions

Unit: mm

Arm length	Standard 2.60 m	Long 3.10 m
A Overall length	8,550	8,560
B Overall height (to top of boom)	2,930	3,090
C Overall width of crawler	SK180LC	2,800
	SK180N	2,490
D Overall height (to top of cab)	3,060	
D' Overall height (to top of handrail)	3,080	
E Ground clearance of rear end*	1,050	
F Ground clearance*	440	
G Tail swing radius	2,550	

G'	Distance from centre of swing to rear end	2,550	
H	Tumbler distance	SK180LC	3,660
		SK180N	3,280
I	Overall length of crawler	SK180LC	4,450
		SK180N	4,070
J	Track gauge	SK180LC	2,200
		SK180N	1,990
K	Shoe width	SK180LC	600
		SK180N	500
L	Overall width of upperstructure	2,490	

*Without including height of shoe lug

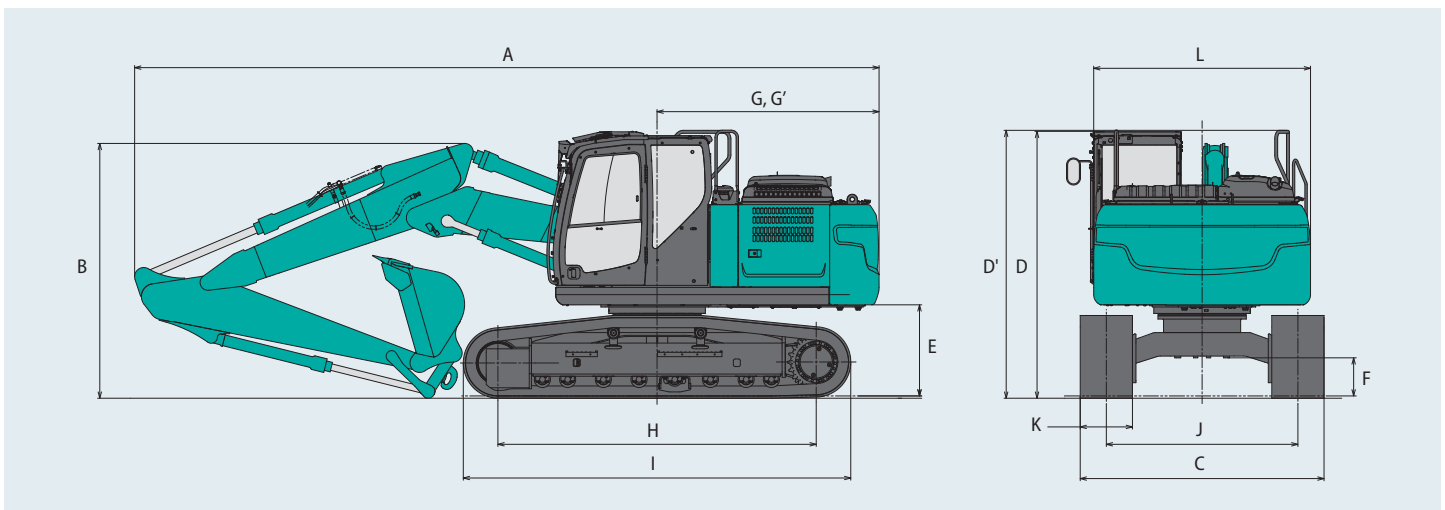

Operating weight & ground pressure

In standard trim, with 2 Piece Boom, 2.60 m arm, and 0.63 m³ ISO heaped bucket.

Shaped			Triple grouser shoes (even height)				
Shoe width	mm		500	600	700	790	900
Overall width of crawler	SK180LC	mm	—	2,800	2,900	2,990	3,100
	SK180N	mm	2,490	2,590	2,690	2,780	—
Ground pressure	SK180LC	kPa	—	42	37	33	30
	SK180N	kPa	54	46	40	36	—
Operating weight	SK180LC	kg	—	20,400	20,900	21,100	21,400
	SK180N	kg	19,700	19,900	20,300	20,500	—

Lift capacities

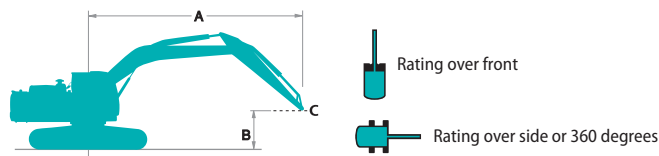





















A - Reach from swing centerline to arm top
 B - Arm top height above/below ground
 C - Lift point
 Relief valve setting: 37.8 MPa

SK180LC		2 Piece Boom		Arm: 2.60 m		Bucket: without		Counterweight: 3,700 kg		Shoe: 600 mm (Heavy Lift)			
A		1.5 m		3.0 m		4.5 m		6.0 m		At max. reach			
B												Radius	
7.5 m	kg					*4,010	*4,010			*3,200	*3,200	4.75 m	
6.0 m	kg					*5,410	*5,410	*3,500	*3,500	*2,830	*2,830	6.15 m	
4.5 m	kg			*6,910	*6,910	*6,710	6,650	*3,990	*3,990	*2,730	*2,730	6.96 m	
3.0 m	kg	*19,920	*19,920	*11,500	*11,500	*7,540	6,190	*3,680	*3,680	*2,790	*2,790	7.38 m	
1.5 m	kg	*19,300	*19,300	*12,570	10,530	*8,080	5,730	*4,010	3,820	*2,990	2,770	7.48 m	
G.L.	kg	*16,090	*16,090	*8,240	*8,240	*7,840	5,460	*5,080	3,680	*3,400	2,830	7.26 m	
-1.5 m	kg			*8,770	*8,770	*6,700	5,390	*4,840	3,630	*3,870	3,150	6.71 m	
-3.0 m	kg			*5,510	*5,510	*4,470	*4,470			*2,960	*2,960	5.72 m	

SK180LC		2 Piece Boom		Arm: 3.10 m		Bucket: without		Counterweight: 3,700 kg		Shoe: 600 mm (Heavy Lift)				
A		1.5 m		3.0 m		4.5 m		6.0 m		7.5 m		At max. reach		
B												Radius		
9.0 m	kg			*3,810	*3,810							*3,220	*3,220	3.27 m
7.5 m	kg					*4,040	*4,040					*2,340	*2,340	5.54 m
6.0 m	kg					*4,360	*4,360	*3,800	*3,800			*2,090	*2,090	6.78 m
4.5 m	kg			*4,600	*4,600	*5,060	*5,060	*3,140	*3,140	*2,110	*2,110	*2,000	*2,000	7.52 m
3.0 m	kg	*17,700	*17,700	*10,560	*10,560	*7,150	6,300	*2,810	*2,810	*3,630	2,850	*2,030	*2,030	7.91 m
1.5 m	kg	*26,860	*26,860	*9,580	*9,580	*7,890	5,790	*3,040	*3,040	*3,930	2,750	*2,140	*2,140	8.00 m
G.L.	kg	*18,600	*18,600	*8,420	*8,420	*7,930	5,450	*4,000	3,650	*4,210	2,670	*2,380	*2,380	7.80 m
-1.5 m	kg	*6,280	*6,280	*9,870	*9,870	*7,110	5,320	*5,170	3,560			*2,840	2,760	7.28 m
-3.0 m	kg			*6,920	*6,920	*5,290	*5,290	*3,560	*3,560			*2,950	*2,950	6.38 m
-4.5 m	kg	*13,470	*13,470	*6,700	*6,700							*1,300	*1,300	4.87 m

Lift capacities

SK180N		2 Piece Boom Arm: 2.60 m Bucket: without Counterweight: 3,700 kg Shoe: 500 mm (Heavy Lift)										
B	A	1.5 m		3.0 m		4.5 m		6.0 m		At max. reach		Radius
												
7.5 m	kg					*4,010	*4,010			*3,200	*3,200	4.75 m
6.0 m	kg					*5,410	*5,410	*3,500	*3,500	*2,830	*2,830	6.15 m
4.5 m	kg			*6,910	*6,910	*6,710	5,830	*3,990	3,690	*2,730	*2,730	6.96 m
3.0 m	kg	*19,920	*19,920	*11,500	9,870	*7,540	5,380	*3,680	3,510	*2,790	2,520	7.38 m
1.5 m	kg	*19,300	*19,300	*12,570	8,870	*8,080	4,940	*4,010	3,310	*2,990	2,400	7.48 m
G.L.	kg	*16,090	*16,090	*8,240	*8,240	*7,840	4,680	*5,080	3,170	*3,400	2,450	7.26 m
-1.5 m	kg			*8,770	8,480	*6,700	4,610	*4,840	3,130	*3,870	2,710	6.71 m
-3.0 m	kg			*5,510	*5,510	*4,470	*4,470			*2,960	*2,960	5.72 m

SK180N		2 Piece Boom Arm: 3.10 m Bucket: without Counterweight: 3,700 kg Shoe: 500 mm (Heavy Lift)												
B	A	1.5 m		3.0 m		4.5 m		6.0 m		7.5 m		At max. reach		Radius
														
9.0 m	kg			*3,810	*3,810							*3,220	*3,220	3.27 m
7.5 m	kg					*4,040	*4,040					*2,340	*2,340	5.54 m
6.0 m	kg					*4,360	*4,360	*3,800	*3,800			*2,090	*2,090	6.78 m
4.5 m	kg			*4,600	*4,600	*5,060	*5,060	*3,140	*3,140	*2,110	*2,110	*2,000	*2,000	7.52 m
3.0 m	kg	*17,700	*17,700	*10,560	10,320	*7,150	5,490	*2,810	*2,810	*3,630	2,470	*2,030	*2,030	7.91 m
1.5 m	kg	*26,860	*26,860	*9,580	8,950	*7,890	5,000	*3,040	*3,040	3,900	2,370	*2,140	2,140	8.00 m
G.L.	kg	*18,600	*18,600	*8,420	8,410	*7,930	4,670	*4,000	3,140	3,820	2,300	*2,380	2,170	7.80 m
-1.5 m	kg	*6,280	*6,280	*9,870	8,340	*7,110	4,540	*5,170	3,060			*2,840	2,370	7.28 m
-3.0 m	kg			*6,920	*6,920	*5,290	4,580	*3,560	3,110			*2,950	2,880	6.38 m
-4.5 m	kg	*13,470	*13,470	*6,700	*6,700							*1,300	*1,300	4.87 m

Notes:

- Do not attempt to lift or hold any load that is greater than these lift capacities at their specified lift point radius and heights. Weight of all accessories must be deducted from the above lift capacities.
- Lift capacities are based on machine standing on level, firm, and uniform ground. User must make allowance for job conditions such as soft or uneven ground, out of level conditions, side loads, sudden stopping of loads, hazardous conditions, experience of personnel, etc.
- Arm top defined as lift point.
- The above lift capacities are in compliance with ISO 10567. They do not exceed 87% of hydraulic lift capacity or 75% of tipping load. Lift capacities marked with an asterisk (*) are limited by hydraulic capacity rather than tipping load.
- Operator should be fully acquainted with the Operator's and Maintenance Instructions before operating this machine. Rules for safe operation of equipment should be adhered to at all times.
- Lift capacities apply to only machine as originally manufactured and normally equipped by KOBELCO CONSTRUCTION MACHINERY CO., LTD.

Standard and Optional Equipment

SK180_{LC}
SK180LC-11E

SK180_N
SK180N-11E

● = Std ○ = Opt — = N/A

Category	Description	SK180LC/N-11E	
		Mono boom / 2 Piece Boom	
		LC	N
ENGINE	YANMAR 4TN107FHT (EU Stage V compliant)	●	●
	Exhaust DOC DPF SCR system	●	●
	Alternator 24 V / 80 A	●	●
	Starter motor 24 V / 5 kW	●	●
	Batteries 2 x 12 V (105 Ah)	●	●
	Fan suction type cooling system	●	●
	Auto deceleration function	●	●
	Auto Idle Stop (AIS)	●	●
HYDRAULIC SYSTEM	3 work modes H, S, Eco	●	●
	Power boost (37.8 MPa)	●	●
	Heavy lift mode	●	●
	Pressure release function	●	●
	Independent travel function	●	●
	Auto warm up system	●	●
	Proportional Hand Control (for E&N&B piping)	●	●
	Hydraulic oil VG32	●	●
	Hydraulic oil VG46	○	○
Hydraulic oil VG68	○	○	
PIPING	E & N&B piping	●	●
	QH piping	●	●
CABIN	Air suspension seat with heating	●	●
	10 inch colour monitor	●	●
	LED door light	●	●
	Air-conditioner	●	●
	DAB+ radio (FM/AM & AUX & USB & Bluetooth* & hands free telephone)	●	●
	Harness for CAB four lights and CAB yellow flasher	●	●
	Parallel wiper	●	●
	12 V power outlet	●	●
	Rain visor	○	○
	Sun screen	●	●
Large footrest	●	●	
LIGHTS	LED work lights ; 2 on Boom, 1 on upper frame, 2 on rear counterweight	●	●
	LED work lights ; 2 on Cab top front	○	○
WORKING EQUIPMENT	Standard Boom (5.20 m)	●	●
	2 Piece Boom	○	○
	Standard arm (2.60 m) with rock guard	●	●
	Long arm (3.10 m) with rock guard	○	○
	Bucket link with lifting hook	●	●
COUNTERWEIGHT	Standard C/W (TTL 3,700 kg)	●	●
UNDERCARRIAGE	500 mm steel shoe	—	●
	600 mm steel shoe	●	○
	700 mm steel shoe	○	○
	790 mm steel shoe	○	○
	900 mm steel shoe	○	—
	Track guide (one per side)	●	●
	Additional track guides (two additional per side)	○	○
SAFETY	Lower frame guard	●	●
	Engine emergency stop switch	●	●
	Pump emergency mode (KPSS release switch)	●	●
	Emergency accel dial	●	●
	Emergency manual valve for lowering attachment	●	●
	Overload alarm	●	●
	Safety valve for boom & arm cylinder	●	●
	ROPS compliant cab (ISO 12117-2:2008)	●	●
	OPG Level II top guard (ISO 10262;1998)	●	●
	OPG Level II front guard (ISO 10262;1998)	○	○
	Eagle-eye view camera (Rear, Right, Left)	●	●
	Seatbelt indicator on display	●	●
	Travel alarm	○	○
Emergency escape hammer	●	●	
OTHERS	Refueling pump	●	●
	Harness for engine room light	●	●
	RAL color	○	○
	KOMEXS	●	●

*The air conditioning system on this machine contains fluorinated greenhouse gas HFC-134a (GWP 1430). Quantity of gas 0.9 kg (CO2 equivalent 1.3 t).
Note: Bluetooth* is a registered trademark of the Bluetooth SIG Inc.

SK180_{LC}
SK180LC-11E

SK180_N
SK180N-11E

Note: This catalogue may contain attachments and optional equipment that are not available in your area. And it may contain photographs of machines with specifications that differ from those of machines sold in your areas. Please consult your nearest KOBELCO distributor for those items you require.
Specialist equipment is needed to use this machine in demolition work. Before using it please contact your KOBELCO dealer.
Due to our policy of continuous product improvements all designs and specifications are subject to change without advance notice.
Copyright by **KOBELCO CONSTRUCTION MACHINERY CO., LTD.** No part of this catalogue may be reproduced in any manner without notice.

KOBELCO CONSTRUCTION MACHINERY EUROPE B.V.

Veluwezoom 15
1327 AE Almere
The Netherlands
www.kobelco-europe.com

Enquiries To: