

# KOBELCO

SK210LC-11E/ SK210NLC-11E/SK210SNLC-11E

Performance  Design

## SK210<sub>LC</sub>

## SK210<sub>NLC</sub>

## SK210<sub>SNLC</sub>

- Bucket capacity:  
0.45 – 0.80 m<sup>3</sup>
- Engine power:  
127 kW / 2,000 min<sup>-1</sup>
- Operating weight:  
22,100 – 24,600 kg



Complies with the EU Stage V  
exhaust emission regulation

*Built for Perfectionists*



# Performance Design

SK210LC/SK210NLC/SK210SNLC of KOBELCO has realised a completely new value by harmonising PERFORMANCE and DESIGN.

Performance enhancements offer greater efficiency and productivity along with increased power and speed.

Design improvements provide the ultimate in comfort and control.

KOBELCO refuses to compromise, creating machines that meet every challenge.



# THE ULTIMATE IN SIMPLE DESIGN

In our pursuit of functional beauty and styling,  
we created an all new interior design focused with the operator in mind.

## Jog Dial

This dial integrates multiple functions into a single, easy to use interface. Even with gloves on, the operator can make the adjustments they need.

## LED Illumination

Dials and buttons are now backlit to provide a bright, clear view in any lighting condition.







# UNFORGETTABLE COMFORT

## Air suspension seat

A GRAMMER\* seat is installed as standard equipment, which achieves excellent shock absorption and superior ride comfort.

\*GRAMMER is trademark of GRAMMER AG, registered in Germany and other countries.

## Multi Vent Air Conditioner

Cool air is blown from multiple outlets toward the operator's body for more comfortable operation.

## Ergonomic Lever Angles

Operators can move levers horizontally without twisting their wrists, reducing fatigue.



## New Hydraulic Control

Our newly upgraded hydraulic control system responds to shorter lever strokes than previous models, delivering swifter, more precise movement and improved lever operability.

## LED Interior Light

Interior lights turn on and off automatically when the door is open or the ignition is turned to the OFF position. This ensures safe entry and exit in the dark.

## Parallel wipers secure a wide field of view



# KOBELCO



04:33



SETTING MENU



PICTURE OF CAMERA



CLOCK SETTING



SCREEN BRIGHTNESS



MAINTENANCE



CONSUMPTION



LANGUAGE SELECTION



PRESSURE RELEASE



# SAFETY ON FULL DISPLAY

## Standard 3 Sides Safety Camera System

Our high-resolution, large display shows right, left and rear side cameras together. Multiple display allows the operator to customize viewing needs to enhance operator awareness and jobsite safety.

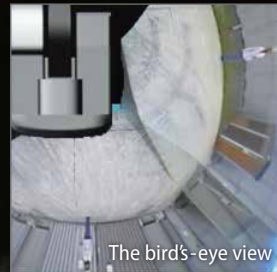
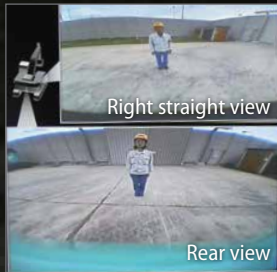

## Large 10-Inch Color Monitor

The easy-to-operate menu screen and recognizable icons assist the operator to select the most important information needed to ensure jobsite safety and machine control.



## Dial in the Right Information

Simply turn the jog dial to the right or left to select an operational feature, then press the dial to confirm selection.





### Independent Travel

Selecting Independent Travel dedicates one hydraulic pump to travel and one to the attachment on a continuous basis, allowing for a smooth and constant movement speed even while swinging or using the boom or attachment. With Independent Travel, safely carrying a large pipe across a job site is a breeze.

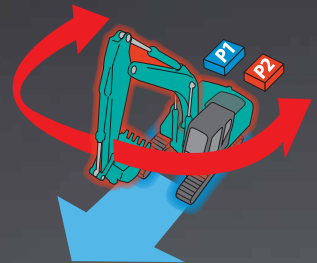

## EXPERIENCING A COMPETENT PERFORMANCE

### Higher Efficiency, plus a EU Stage V Compliant Engine

The new SK210LC/NLC/SNLC is equipped with a Yanmar Stage V compliant engine, which has a higher torque value. Superior balance between engine output and torque contributes to more efficient performance than the previous models. In addition, the DPF replacement interval has been extended.

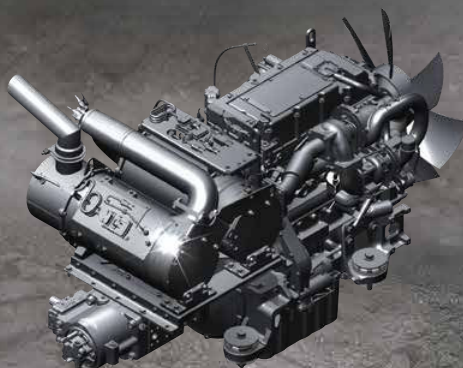

Model: YANMAR 4TN107FTT

Engine output

**127 kW / 2,000 min<sup>-1</sup>**



»» Max. bucket digging force (Arm 2.94 m)

Normal: **143** kN

With Power Boost: **157** kN

Lift capacity

**11,820** kg

(Reach: 4.50 m Boom: 5.65 m Arm: 2.94 m Bucket: Without Counterweight: 4,800 kg Shoe: 600 mm <Heavy Lift>)



# GREATER MULTI-FUNCTION CAPABILITIES

## Attachment mode selection

The auxiliary flow rates for the bucket, breaker, nibbler, and rotating are all now adjustable by the operator through the monitor, allowing you to change tools quickly and easily. Mode settings for other attachments like the tilt rotator can be added or changed.



# EASY MAINTENANCE



## Standard Overhead Top Guard Level II

The standard overhead cab guard can be tilted open with gas damper for easy window cleaning. Meets standard top guard level II requirements. (ISO 10262)



## Engine Maintenance

Lower service platform makes engine service easier.



## Two-Stage Air Filter



## DEF/AdBlue<sup>®</sup> Tank

The DEF/AdBlue<sup>®</sup> fill is located inside the locking tool box.



## Left Side (Radiator and Cooling System Elements)

Laid out for easy access to radiator and cooling system.



## Right Side (Ground Level Maintenance)

Hydraulic pump and engine filter compartment.



## Fuel Filter / Pre-Filter with Integrated Water Separator



## Engine Oil Filter

Note: AdBlue<sup>®</sup> is a registered trademark of the Verband der Automobilindustrie e.V. (VDA).

# DURABILITY YOU CAN TRUST

## Enhanced body rigidity for 20-ton class machines

The SK210LC, SK210NLC and SK210SNLC machines are widely used in mid-scale construction projects and harsh worksites. The components have been reviewed and improvements have been made to their durability to ensure stable performance in such environments.



### Panels and supports

The right and left side panels and rear supports have been thicker to enhance body rigidity.



### Bucket cylinder rod pin

The increased diameter of the bucket cylinder rod pin contributes to enhanced durability for various types of attachments.

# CONVENIENT AND SENSIBLE EQUIPMENT



## Engine start password

A password is required when starting the engine for greater security.



## Wiper adjustment function

In addition to the intermittent wiper mode and continuous wiper mode, the one-time wiper mode was added.



## Parallel wipers

Sun screen



## Console mount

The console-integrated seat allows for comfortable operation.



## DAB+ radio (FM/AM & AUX & USB & Bluetooth® & hands-free telephone)



## USB port/12 V power outlet



## Smartphone holder

You can use the holder with your smartphone connected to the USB port.



# KOBELCO MONITORING EXCAVATOR SYSTEM

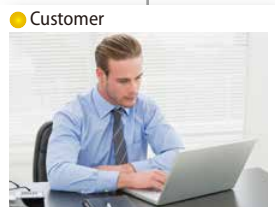

Customer



KOBELCO office



KOBELCO service personnel

## Remote Monitoring for Peace of Mind

KOMEXS (Kobelco Monitoring Excavator System) uses satellite communication and internet to relay data, and therefore can be deployed in areas where other forms of communication are difficult. When a hydraulic excavator is fitted with this system, data on the machine's operation, such as operating hours, location, fuel consumption, and maintenance status can be obtained remotely.

## Direct Access to Operational Status

### Location Data

Accurate location data can be obtained even from sites where communications are difficult.

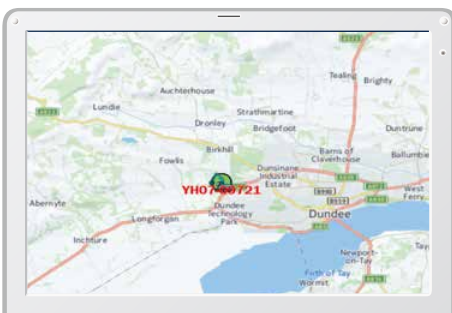

Latest location

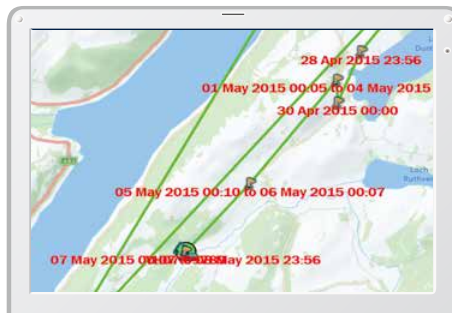

Location records

| Period            | 11 Apr, 2015 | to | 10 May, 2015 | Search |
|-------------------|--------------|----|--------------|--------|
| Type of Operation | Working Hrs  |    | Ratio        |        |
| Total Working Hrs | 169 Hrs      |    | 100 %        |        |
| Digging Hrs       | 72.2 Hrs     |    | 43 %         |        |
| Traveling Hrs     | 18.3 Hrs     |    | 11 %         |        |
| Idle Hrs          | 15.9 Hrs     |    | 9 %          |        |
| Opt Att Hrs       | 62.5 Hrs     |    | 37 %         |        |
| Crane Mode Hrs    | 0 Hrs        |    | 0 %          |        |

Work data

## Operating Hours

- A comparison of operating times of machines at multiple locations shows which locations are busier and more profitable.
- Operating hours on site can be accurately recorded, for running time calculations needed for rental machines, etc.

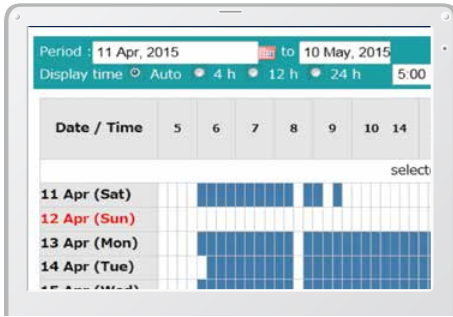

Daily report

## Fuel Consumption Data

Data on fuel consumption and idling times can be used to indicate improvements in fuel consumption.

| Work mode    | Working Hrs   | Total Fuel Consumption |
|--------------|---------------|------------------------|
| H mode       | 2:06          | 24.5 L                 |
| S mode       | 0:00          | 0.0 L                  |
| E mode       | 169:19        | 1489.7 L               |
| <b>TOTAL</b> | <b>171:25</b> | <b>1514.2 L</b>        |

Fuel consumption

## Graph of Work Content

The graph shows how working hours are divided among different operating categories, including digging, idling, travelling and optional operations.

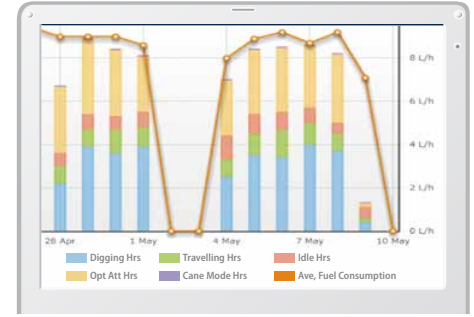

Work status

## Maintenance Data and Warning Alerts

### Machine Maintenance Data

- Provides maintenance status of separate machines operating at multiple sites.
- Maintenance data is also relayed to KOBELCO service personnel, for more efficient planning of periodic servicing.

| Model                | Serial No.                 | Hour Meter | Engine Oil |
|----------------------|----------------------------|------------|------------|
| SK135SRLC-3/SK140SRL | <a href="#">YH07-09721</a> | 734 Hr     | 434        |
| SK135SRLC-3/SK140SRL | <a href="#">YH07-09789</a> | 73 Hr      | 429        |
| SK210LC-9            | <a href="#">YQ13-10454</a> | 960 Hr     | 58         |
| SK210LC-9            | <a href="#">YQ13-10481</a> | 549 Hr     | 498        |
| SK75SR-              | <a href="#">YT08-30374</a> |            |            |

Maintenance

### Warning Alerts

This system warns an alert if an anomaly is sensed, preventing damage that could result in machine downtime.

## Alarm Information Can Be Received through E-mail

Alarm information or maintenance notice can be received through E-mail, using a computer or cell phone.



Alarm messages can be received on mobile device.

## Daily/Monthly Reports

Operational data downloaded onto a computer helps in formulating daily and monthly reports.

## Security System

### Engine Start Alarm

The system can be set an alarm if the machine is operated outside designated time.

Setting Condition

Setting Condition Change

Start time 20 : 00

Release time 07 : 00

No Working Whole Day

Mon Tue Wed Thu Fri Sat Sun

Clear

Engine start alarm outside prescribed work time

### Area Alarm

It can be set an alarm if the machine is moved out of its designated area to another location.

Setting Condition

Around the current (latest) location 1 Km

Input Latitude and Longitude

Latitude1

Longitude1

Latitude2

Longitude2

Map Clear

Release

Alarm for outside of reset area

# Specifications

## Engine

| Model              | YANMAR 4TN107FTT  |
|--------------------|---|
| Type               | Four-cycle, water-cooled, direct injection diesel engine, turbo charged, EU Stage V exhaust emission regulation |
| No. of cylinders   | 4   |
| Bore and stroke    | 107 mm × 127 mm   |
| Displacement       | 4.567 L   |
| Rated power output | 122 kW / 2,000 min <sup>-1</sup> (ISO 9249 : with fan)  |
|                    | 127 kW / 2,000 min <sup>-1</sup> (ISO 14396: without fan)   |
| Max. torque        | 791 N-m / 1,500 min <sup>-1</sup> (ISO 9249: with fan)  |
|                    | 805 N-m / 1,500 min <sup>-1</sup> (ISO 14396: without fan)  |

## Hydraulic system

| Pump                 |  |
|----------------------|--|
| Type                 | Two variable displacement axial piston pumps + extra gear pump + pilot gear pump |
| Max. discharge flow  | 2 × 220 L/min, 1 × 40.6 L/min, 1 × 20 L/min                                      |
| Relief valve setting |  |
| Boom, arm and bucket | 34.3 MPa   |
| Power Boost*         | 37.8 MPa   |
| Travel circuit       | 34.3 MPa   |
| Swing circuit        | 29.0 MPa   |
| Control circuit      | 5.0 MPa  |
| Pilot control pump   | Gear type  |
| Main control valve   | 8-Spool valve  |
| Oil cooler           | Air cooled type  |

\*Not available for Long Reach

## Swing system

|                                  |  |
|----------------------------------|--|
| Swing motor                      | One fixed displacement piston motor  |
| Brake                            | Hydraulic; locking automatically when the swing control lever is in the neutral position |
| Parking brake                    | Wet multiple plate   |
| Swing speed                      | 12.7 min <sup>-1</sup>   |
| Swing torque                     | 71.5 kN-m  |
| Maximum swing gradient (Loaded)* | 30 % {17 °}  |

\*Value for the least favourable specification

## Attachments

Backhoe bucket and combination

| Use             | Backhoe bucket         |                |      |       |       |
|-----------------|------------------------|----------------|------|-------|-------|
|                 | Normal digging         |                |      |       |       |
| Bucket capacity | ISO heaped             | m <sup>3</sup> | 0.45 | 0.70  | 0.80  |
| Opening width   | With side cutter       | mm             | 910  | 1,080 | 1,160 |
|                 | Without side cutter    | mm             | 815  | 980   | 1,140 |
| No. of teeth    |                        |                | 5    | 5     | 5     |
| Bucket weight   |                        | kg             | 360  | 630   | 660   |
| Combination     | 2.40 m short arm       |                | —    | ○     | ○     |
|                 | 2.94 m standard arm    |                | —    | ○     | ◎     |
|                 | 3.50 m long arm        |                | —    | ◎     | △     |
|                 | 6.35m arm (Long Reach) |                | ◎    | —     | —     |

◎ Standard ○ Recommended △ Loading only

## Travel system

|                    |                                   |
|--------------------|-----------------------------------|
| Travel motors      | 2 × axial-piston, two-step motors |
| Travel brakes      | Hydraulic brake per motor         |
| Parking brakes     | Oil disc brake per motor          |
| Travel shoes       | 49 each side                      |
| Travel speed       | 6.0/3.6 km/h                      |
| Rated drawbar pull | 228 kN (SAE J 1309)               |
| Gradeability       | 70% {35°}                         |

## Cab & control

### Cab

All-weather, sound-suppressed steel cab mounted on the high suspension mounts filled with silicone oil and equipped with a heavy, insulated floor mat.

### Control

Two hand levers and two foot pedals for travel

Two hand levers for excavating and swing

Electric rotary-type engine throttle

### Noise levels

External 103 dB(A) (2000/14/EC)

Operator 71 dB(A) (ISO 6396)

### Vibration levels

Hand/arm\* ≤ 2.5 m/s<sup>2</sup>

Body\* ≤ 0.5 m/s<sup>2</sup>

\*For the risk assessment according to 2002/44/EC, refer to ISO/TR 25398: 2006

## Cylinders

|                              |                                       |
|------------------------------|---------------------------------------|
| Boom cylinders               | 120 mm × 1,355 mm                     |
| Arm cylinder (Long Reach)    | 135 mm × 1,558 mm (135 mm × 1,489 mm) |
| Bucket cylinder (Long Reach) | 120 mm × 1,080 mm (95 mm × 885 mm)    |
| Jib cylinder*                | 150 mm × 992 mm                       |

\*For 2 Piece boom only

## Refilling capacities & lubrications

|                       |                        |
|-----------------------|------------------------|
| Fuel tank             | 321 L                  |
| Cooling system        | 23 L                   |
| Engine oil            | 20 L                   |
| Travel reduction gear | 2 × 5.3 L              |
| Swing reduction gear  | 1 × 2.7 L              |
| Hydraulic oil tank    | 140 L tank oil level   |
|                       | 244 L hydraulic system |
| DEF/ Urea tank        | SK210LC/NLC 83 L       |
|                       | SK210SNLC 34 L         |

# SK210<sup>LC</sup>

SK210LC-11E

# SK210<sup>NLC</sup>

SK210NLC-11E

# SK210<sup>SNLC</sup>

SK210SNLC-11E



## Working ranges

Unit: mm

| Boom   | 5.65 m |              |                 |             |
|--|--------|--------------|-----------------|-------------|
| Range  | Arm    | Short 2.40 m | Standard 2.94 m | Long 3.50 m |
| a- Max. digging reach                        |        | 9,420        | 9,900           | 10,340      |
| b- Max. digging reach at ground level        |        | 9,240        | 9,730           | 10,170      |
| c- Max. digging depth                        |        | 6,160        | 6,700           | 7,260       |
| d- Max. digging height                       |        | 9,510        | 9,720           | 9,750       |
| e- Max. dumping clearance                    |        | 6,680        | 6,910           | 6,970       |
| f- Min. dumping clearance                    |        | 2,980        | 2,430           | 1,870       |
| g- Max. vertical wall digging depth          |        | 5,570        | 6,100           | 6,470       |
| h- Min. swing radius                         |        | 3,560        | 3,550           | 3,480       |
| i- Horizontal digging stroke at ground level |        | 4,080        | 5,270           | 6,080       |
| j- Digging depth for 2.4 m (8') flat bottom  |        | 5,950        | 6,520           | 7,080       |
| Bucket capacity ISO heaped m <sup>3</sup>    |        | 0.93         | 0.80            | 0.70        |

## Digging Force (ISO 6015)

Unit: kN

| Arm length           | Short 2.40 m | Standard 2.94 m | Long 3.50 m  |
|----------------------|--------------|-----------------|--------------|
| Bucket digging force | 143<br>157*  | 143<br>157*     | 143<br>157*  |
| Arm crowding force   | 121<br>133*  | 102<br>112*     | 91.8<br>101* |

\*Power boost engaged

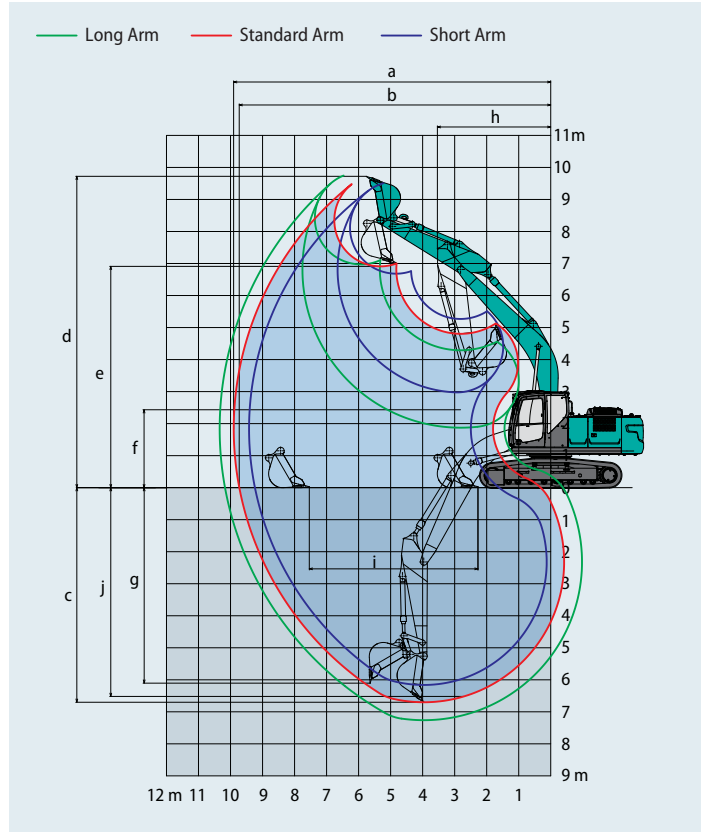

## Dimensions (SK210LC/SK210NLC)

Unit: mm

| Arm length                                   | Short 2.40 m | Standard 2.94 m | Long 3.50 m |
|--|--------------|-----------------|-------------|
| A Overall length                             | 9,680        | 9,600           | 9,670       |
| B Overall height (to top of boom)            | 3,200        | 3,030           | 3,210       |
| C Overall width of crawler                   | SK210LC      | 2,990           |             |
|  | SK210NLC     | 2,800           |             |
| D Overall height (to top of cab)             |              | 3,060           |             |
| E Ground clearance of rear end*              |              | 1,060           |             |
| F Ground clearance*                          |              | 425             |             |
| G Tail swing radius                          |              | 2,910           |             |
| G' Distance from centre of swing to rear end |              | 2,900           |             |
| H Tumbler distance                           |              | 3,660           |             |
| I Overall length of crawler                  |              | 4,450           |             |
| J Track gauge                                | SK210LC      | 2,390           |             |
|  | SK210NLC     | 2,200           |             |
| K Shoe width                                 |              | 600             |             |
| L Overall width of upperstructure            |              | 2,710           |             |

\*Without including height of shoe



## Dimensions (SK210SNLC)

Unit: mm

| Arm length                                   | Short 2.40 m | Standard 2.94 m |
|--|--------------|-----------------|
| A Overall length                             | 9,580        | 9,500           |
| B Overall height (to top of boom)            | 3,200        | 3,030           |
| C Overall width of crawler                   | 2,540        |                 |
| D Overall height (to top of cab)             | 3,060        |                 |
| E Ground clearance of rear end*              | 1,050        |                 |
| F Ground clearance*                          | 425          |                 |
| G Tail swing radius                          | 2,800        |                 |
| G' Distance from centre of swing to rear end | 2,800        |                 |
| H Tumbler distance                           | 3,660        |                 |
| I Overall length of crawler                  | 4,450        |                 |
| J Track gauge                                | 2,040        |                 |
| K Shoe width                                 | 500          |                 |
| L Overall width of upperstructure            | 2,540        |                 |

\*Without including height of shoe

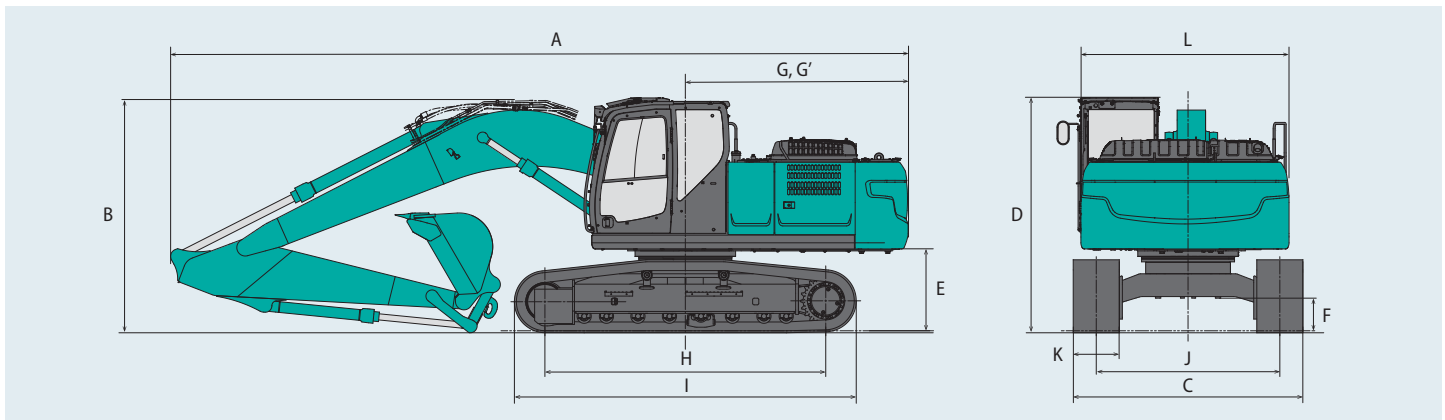

# Operating weight & ground pressure

In standard trim, with standard boom, 2.94 m arm, and 0.8 m³ ISO heaped bucket.

| Shaped                   |           |     | Triple grouser shoes (even height) |        |        |        |        |
|--------------------------|-----------|-----|------------------------------------|--------|--------|--------|--------|
| Shoe width               |           | mm  | 500                                | 600    | 700    | 790    | 900    |
| Overall width of crawler | SK210LC   | mm  | —                                  | 2,990  | 3,090  | 3,180  | 3,290  |
|                          | SK210NLC  | mm  | —                                  | 2,800  | 2,900  | 2,990  | —      |
|                          | SK210SNLC | mm  | 2,540                              | 2,640  | —      | —      | —      |
| Ground pressure          | SK210LC   | kPa | —                                  | 46     | 40     | 36     | 32     |
|                          | SK210NLC  | kPa | —                                  | 46     | 40     | 36     | —      |
|                          | SK210SNLC | kPa | 56                                 | 47     | —      | —      | —      |
| Operating weight         | SK210LC   | kg  | —                                  | 22,100 | 22,500 | 22,700 | 23,100 |
|                          | SK210NLC  | kg  | —                                  | 22,000 | 22,500 | 22,700 | —      |
|                          | SK210SNLC | kg  | 22,500                             | 22,700 | —      | —      | —      |

In standard trim, with standard boom, 2.94 m arm, and 0.8 m³ ISO heaped bucket (optional counterweight 4,800 kg).

| Shaped                   |          |     | Triple grouser shoes (even height) |        |        |        |
|--------------------------|----------|-----|------------------------------------|--------|--------|--------|
| Shoe width               |          | mm  | 600                                | 700    | 790    | 900    |
| Overall width of crawler | SK210LC  | mm  | 2,990                              | 3,090  | 3,180  | 3,290  |
|                          | SK210NLC | mm  | 2,800                              | 2,900  | 2,990  | —      |
| Ground pressure          | SK210LC  | kPa | 47                                 | 41     | 37     | 33     |
|                          | SK210NLC | kPa | 47                                 | 41     | 37     | —      |
| Operating weight         | SK210LC  | kg  | 22,600                             | 23,100 | 23,300 | 23,600 |
|                          | SK210NLC | kg  | 22,500                             | 23,000 | 23,200 | —      |

## Lift capacities

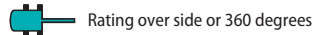
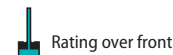
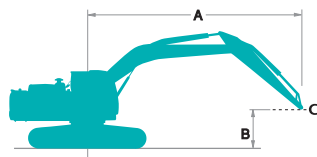

A - Reach from swing centerline to arm top

B - Arm top height above/below ground

C - Lift point

Relief valve setting: 37.8 MPa

| SK210LC |    | Boom: 5.65 m      |                                 | Arm: 2.94 m       |                                 | Bucket: without   |                                 | Counterweight: 4,300 kg |                                 | Shoe: 600 mm (Heavy Lift) |                                 |                   |                                 |        |
|---------|----|-------------------|---------------------------------|-------------------|---------------------------------|-------------------|---------------------------------|-------------------------|---------------------------------|---------------------------|---------------------------------|-------------------|---------------------------------|--------|
| B       | A  | 1.5 m             |                                 | 3.0 m             |                                 | 4.5 m             |                                 | 6.0 m                   |                                 | 7.5 m                     |                                 | At max. reach     |                                 |        |
|         |    | Rating over front | Rating over side or 360 degrees | Rating over front | Rating over side or 360 degrees | Rating over front | Rating over side or 360 degrees | Rating over front       | Rating over side or 360 degrees | Rating over front         | Rating over side or 360 degrees | Rating over front | Rating over side or 360 degrees | Radius |
| 7.5 m   | kg |                   |                                 |                   |                                 |                   |                                 | *5,300                  | *5,300                          |                           |                                 | *4,270            | *4,270                          | 6.26 m |
| 6.0 m   | kg |                   |                                 |                   |                                 |                   |                                 | *5,880                  | 5,480                           |                           |                                 | *3,940            | 3,850                           | 7.36 m |
| 4.5 m   | kg |                   |                                 |                   |                                 |                   |                                 | *6,420                  | 5,280                           | 5,680                     | 3,680                           | *3,860            | 3,270                           | 8.03 m |
| 3.0 m   | kg |                   |                                 |                   |                                 | *9,360            | 7,670                           | *7,270                  | 5,000                           | 5,540                     | 3,560                           | *3,930            | 2,980                           | 8.38 m |
| 1.5 m   | kg |                   |                                 |                   |                                 | *11,040           | 7,100                           | 7,570                   | 4,720                           | 5,400                     | 3,430                           | *4,170            | 2,870                           | 8.45 m |
| G.L.    | kg |                   |                                 | *6,330            | *6,330                          | 11,660            | 6,790                           | 7,360                   | 4,530                           | 5,290                     | 3,330                           | *4,600            | 2,920                           | 8.25 m |
| -1.5 m  | kg | *6,700            | *6,700                          | *11,060           | *11,060                         | 11,560            | 6,700                           | 7,270                   | 4,460                           | 5,260                     | 3,310                           | 5,030             | 3,170                           | 7.75 m |
| -3.0 m  | kg | *11,730           | *11,730                         | *14,650           | 13,240                          | *10,550           | 6,780                           | 7,320                   | 4,510                           |                           |                                 | 6,010             | 3,770                           | 6.89 m |
| -4.5 m  | kg |                   |                                 | *10,860           | *10,860                         | *7,950            | 7,050                           |                         |                                 |                           |                                 | *5,980            | 5,330                           | 5.50 m |

| SK210LC |    | Boom: 5.65 m      |                                 | Arm: 3.50 m       |                                 | Bucket: without   |                                 | Counterweight: 4,300 kg |                                 | Shoe: 600 mm (Heavy Lift) |                                 |                   |                                 |        |
|---------|----|-------------------|---------------------------------|-------------------|---------------------------------|-------------------|---------------------------------|-------------------------|---------------------------------|---------------------------|---------------------------------|-------------------|---------------------------------|--------|
| B       | A  | 1.5 m             |                                 | 3.0 m             |                                 | 4.5 m             |                                 | 6.0 m                   |                                 | 7.5 m                     |                                 | At max. reach     |                                 |        |
|         |    | Rating over front | Rating over side or 360 degrees | Rating over front | Rating over side or 360 degrees | Rating over front | Rating over side or 360 degrees | Rating over front       | Rating over side or 360 degrees | Rating over front         | Rating over side or 360 degrees | Rating over front | Rating over side or 360 degrees | Radius |
| 7.5 m   | kg |                   |                                 |                   |                                 |                   |                                 |                         |                                 |                           |                                 | *3,640            | *3,640                          | 6.84 m |
| 6.0 m   | kg |                   |                                 |                   |                                 |                   |                                 |                         |                                 | *4,540                    | 3,790                           | *3,430            | *3,430                          | 7.86 m |
| 4.5 m   | kg |                   |                                 |                   |                                 |                   |                                 | *5,840                  | 5,350                           | *5,440                    | 3,710                           | *3,400            | 2,970                           | 8.49 m |
| 3.0 m   | kg |                   |                                 | *12,860           | *12,860                         | *8,480            | 7,840                           | *6,750                  | 5,050                           | 5,550                     | 3,560                           | *3,490            | 2,720                           | 8.82 m |
| 1.5 m   | kg |                   |                                 | *7,240            | *7,240                          | *10,380           | 7,190                           | 7,600                   | 4,740                           | 5,380                     | 3,410                           | *3,710            | 2,610                           | 8.89 m |
| G.L.    | kg |                   |                                 | *7,730            | *7,730                          | *11,520           | 6,770                           | 7,330                   | 4,500                           | 5,240                     | 3,280                           | *4,110            | 2,650                           | 8.70 m |
| -1.5 m  | kg | *6,570            | *6,570                          | *10,960           | *10,960                         | 11,470            | 6,610                           | 7,190                   | 4,380                           | 5,170                     | 3,220                           | 4,540             | 2,840                           | 8.22 m |
| -3.0 m  | kg | *10,480           | *10,480                         | *15,820           | 12,950                          | *11,000           | 6,630                           | 7,190                   | 4,380                           |                           |                                 | 5,290             | 3,300                           | 7.42 m |
| -4.5 m  | kg | *15,580           | *15,580                         | *12,690           | *12,690                         | *9,090            | 6,820                           | *6,410                  | 4,540                           |                           |                                 | *6,100            | 4,390                           | 6.16 m |

# SK210<sub>LC</sub>











SK210LC-11E











# SK210<sub>NLC</sub>











SK210NLC-11E











# SK210<sub>SNLC</sub>

SK210SNLC-11E

| SK210LC |    | Boom: 5.65 m Arm: 2.40 m Bucket: without Counterweight: 4,300 kg Shoe: 600 mm (Heavy Lift) |   |   |   |   |   |  |   |   |   |        |        |
|---------|----|--|---|---|---|---|---|--|---|---|---|--------|--------|
| B       | A  | 3.0 m  |   | 4.5 m   |   | 6.0 m   |   | 7.5 m  |   | At max. reach   |   | Radius |        |
|         |    |           |  |  |  |  |  |  |  |  |  |        |        |
| 7.5 m   | kg |  |   |   |   |   |   |  |   |   | *6,320  | 6,030  | 5.58 m |
| 6.0 m   | kg |  |   |   |   | *6,470  | 5,380   |  |   |   | *5,760  | 4,340  | 6.80 m |
| 4.5 m   | kg |  |   | *8,260  | 8,130   | *6,930  | 5,210   | 5,620  | 3,630   |   | 5,590   | 3,610  | 7.52 m |
| 3.0 m   | kg |  |   | *10,100   | 7,490   | *7,700  | 4,940   | 5,520  | 3,540   |   | 5,090   | 3,270  | 7.89 m |
| 1.5 m   | kg |  |   | *11,520   | 6,990   | *7,530  | 4,700   | 5,400  | 3,440   |   | 4,940   | 3,150  | 7.97 m |
| G.L.    | kg |  |   | 11,640  | 6,780   | 7,360   | 4,540   | 5,330  | 3,370   |   | 5,090   | 3,230  | 7.75 m |
| -1.5 m  | kg | *11,440  | *11,440   | *11,390   | 6,760   | 7,320   | 4,510   |  |   |   | 5,630   | 3,560  | 7.22 m |
| -3.0 m  | kg | *13,150  | *13,150   | *9,880  | 6,900   | *7,190  | 4,630   |  |   |   | *6,580  | 4,370  | 6.29 m |
| -4.5 m  | kg |  |   | *6,230  | *6,230  |   |   |  |   |   | *5,690  | *5,690 | 4.72 m |

| SK210LC |    | Boom: 5.65 m Arm: 2.94 m Bucket: without Counterweight: 4,800 kg Shoe: 600 mm (Heavy Lift) |   |   |   |   |   |  |   |   |   |               |        |        |
|---------|----|--|---|---|---|---|---|--|---|---|---|---------------|--------|--------|
| B       | A  | 1.5 m  |   | 3.0 m   |   | 4.5 m   |   | 6.0 m  |   | 7.5 m   |   | At max. reach |        | Radius |
|         |    |           |  |  |  |  |  |  |  |  |  |               |        |        |
| 7.5 m   | kg |  |   |   |   |   |   | *5,300   | *5,300  |   |   | *4,270        | *4,270 | 6.26 m |
| 6.0 m   | kg |  |   |   |   |   |   | *5,880   | 5,840   |   |   | *3,940        | *3,940 | 7.36 m |
| 4.5 m   | kg |  |   |   |   |   |   | *6,420   | 5,640   | *5,910  | 3,960   | *3,860        | 3,520  | 8.03 m |
| 3.0 m   | kg |  |   |   |   | *9,360  | 8,200   | *7,270   | 5,360   | 5,890   | 3,840   | *3,930        | 3,210  | 8.38 m |
| 1.5 m   | kg |  |   |   |   | *11,040   | 7,620   | 8,040  | 5,090   | 5,740   | 3,700   | *4,170        | 3,110  | 8.45 m |
| G.L.    | kg |  |   | *6,330  | *6,330  | *11,820   | 7,310   | 7,820  | 4,890   | 5,630   | 3,600   | *4,600        | 3,170  | 8.25 m |
| -1.5 m  | kg | *6,700   | *6,700  | *11,060   | *11,060   | *11,650   | 7,230   | 7,740  | 4,820   | 5,610   | 3,580   | 5,360         | 3,440  | 7.75 m |
| -3.0 m  | kg | *11,730  | *11,730   | *14,650   | 14,230  | *10,550   | 7,310   | 7,790  | 4,870   |   |   | *6,330        | 4,080  | 6.89 m |
| -4.5 m  | kg |  |   | *10,860   | *10,860   | *7,950  | 7,570   |  |   |   |   | *5,980        | 5,730  | 5.50 m |

| SK210LC |    | Boom: 5.65 m Arm: 3.50 m Bucket: without Counterweight: 4,800 kg Shoe: 600 mm (Heavy Lift) |   |   |   |   |   |  |   |   |   |               |        |        |        |        |
|---------|----|--|---|---|---|---|---|--|---|---|---|---------------|--------|--------|--------|--------|
| B       | A  | 1.5 m  |   | 3.0 m   |   | 4.5 m   |   | 6.0 m  |   | 7.5 m   |   | At max. reach |        | Radius |        |        |
|         |    |         |  |  |  |  |  |  |  |  |  |               |        |        |        |        |
| 7.5 m   | kg |  |   |   |   |   |   |  |   |   |   | *3,640        | *3,640 | 6.84 m |        |        |
| 6.0 m   | kg |  |   |   |   |   |   |  |   |   |   | *4,540        | 4,060  | *3,430 | *3,430 | 7.86 m |
| 4.5 m   | kg |  |   |   |   |   |   | *5,840   | 5,710   |   |   | *5,440        | 3,980  | *3,400 | 3,210  | 8.49 m |
| 3.0 m   | kg |  |   |   |   | *12,860   | *12,860   | *8,480   | 8,370   | *6,750  | 5,410   | *5,860        | 3,840  | *3,490 | 2,940  | 8.82 m |
| 1.5 m   | kg |  |   |   |   | *7,240  | *7,240  | *10,380  | 7,720   | *7,700  | 5,100   | 5,720         | 3,680  | *3,710 | 2,840  | 8.89 m |
| G.L.    | kg |  |   | *7,730  | *7,730  | *11,520   | 7,300   | 7,800  | 4,860   | 5,590   | 3,550   | *4,110        | 2,880  | 8.70 m |        |        |
| -1.5 m  | kg | *6,570   | *6,570  | *10,960   | *10,960   | *11,710   | 7,140   | 7,660  | 4,740   | 5,200   | 3,490   | *4,820        | 3,080  | 8.22 m |        |        |
| -3.0 m  | kg | *10,480  | *10,480   | *15,820   | 13,940  | *11,000   | 7,160   | 7,660  | 4,740   |   |   | 5,640         | 3,580  | 7.42 m |        |        |
| -4.5 m  | kg | *15,580  | *15,580   | *12,690   | *12,690   | *9,090  | 7,350   | *6,410   | 4,900   |   |   | *6,100        | 4,740  | 6.16 m |        |        |













| SK210LC |    | Boom: 5.65 m Arm: 2.40 m Bucket: without Counterweight: 4,800 kg Shoe: 600 mm (Heavy Lift) |   |   |   |   |   |  |   |   |   |        |        |        |
|---------|----|--|---|---|---|---|---|--|---|---|---|--------|--------|--------|
| B       | A  | 3.0 m  |   | 4.5 m   |   | 6.0 m   |   | 7.5 m  |   | At max. reach   |   | Radius |        |        |
|         |    |         |  |  |  |  |  |  |  |  |  |        |        |        |
| 7.5 m   | kg |  |   |   |   |   |   |  |   |   |   | *6,320 | *6,320 | 5.58 m |
| 6.0 m   | kg |  |   |   |   | *6,470  | 5,740   |  |   |   |   | *5,760 | 4,650  | 6.80 m |
| 4.5 m   | kg |  |   | *8,260  | *8,260  | *6,930  | 5,570   | *5,850   | 3,910   |   |   | *5,610 | 3,880  | 7.52 m |
| 3.0 m   | kg |  |   | *10,100   | 8,020   | *7,700  | 5,300   | 5,860  | 3,820   |   |   | 5,410  | 3,520  | 7.89 m |
| 1.5 m   | kg |  |   | *11,520   | 7,520   | 8,000   | 5,060   | 5,740  | 3,710   |   |   | 5,250  | 3,400  | 7.97 m |
| G.L.    | kg |  |   | *11,920   | 7,310   | 7,830   | 4,900   | 5,670  | 3,640   |   |   | 5,420  | 3,490  | 7.75 m |
| -1.5 m  | kg | *11,440  | *11,440   | *11,390   | 7,290   | 7,790   | 4,870   |  |   |   |   | 6,000  | 3,840  | 7.22 m |
| -3.0 m  | kg | *13,150  | *13,150   | *9,880  | 7,430   | *7,190  | 4,990   |  |   |   |   | *6,580 | 4,710  | 6.29 m |
| -4.5 m  | kg |  |   | *6,230  | *6,230  |   |   |  |   |   |   | *5,690 | *5,690 | 4.72 m |











### Notes:











- Do not attempt to lift or hold any load that is greater than these lift capacities at their specified lift point radius and heights. Weight of all accessories must be deducted from the above lift capacities.
- Lift capacities are based on machine standing on level, firm, and uniform ground. User must make allowance for job conditions such as soft or uneven ground, out of level conditions, side loads, sudden stopping of loads, hazardous conditions, experience of personnel, etc.
- Arm top defined as lift point.
- The above lift capacities are in compliance with ISO 10567. They do not exceed 87% of hydraulic lift













capacity or 75% of tipping load. Lift capacities marked with an asterisk (\*) are limited by hydraulic capacity rather than tipping load.

- Operator should be fully acquainted with the Operator's and Maintenance Instructions before operating this machine. Rules for safe operation of equipment should be adhered to at all times.
- Lift capacities apply to only machine as originally manufactured and normally equipped by KOBELCO CONSTRUCTION MACHINERY CO., LTD.

| SK210NLC |    | Boom: 5.65 m Arm: 2.94 m Bucket: without Counterweight: 4,300 kg Shoe: 600 mm (Heavy Lift) |   |   |   |   |   |   |   |   |   |   |   |        |        |
|----------|----|--|---|---|---|---|---|---|---|---|---|---|---|--------|--------|
| B        | A  | 1.5 m  |   | 3.0 m   |   | 4.5 m   |   | 6.0 m   |   | 7.5 m   |   | At max. reach   |   | Radius |        |
|          |    |           |  |  |  |  |  |  |  |  |  |  |  |        |        |
| 7.5 m    | kg |  |   |   |   |   |   | *5,300  | 5,060   |   |   | *4,270  | *4,270  | 6.26 m |        |
| 6.0 m    | kg |  |   |   |   |   |   | *5,880  | 5,050   |   |   | *3,940  | 3,540   | 7.36 m |        |
| 4.5 m    | kg |  |   |   |   |   |   | *6,420  | 4,850   | 5,670   | 3,380   | *3,860  | 2,990   | 8.03 m |        |
| 3.0 m    | kg |  |   |   |   |   | *9,360  | 6,980   | *7,270  | 4,580   | 5,530   | 3,260   | *3,930  | 2,720  | 8.38 m |
| 1.5 m    | kg |  |   |   |   |   | *11,040   | 6,420   | 7,560   | 4,310   | 5,390   | 3,130   | *4,170  | 2,620  | 8.45 m |
| G.L.     | kg |  |   | *6,330  | *6,330  | 11,630  | 6,120   | 7,340   | 4,120   | 5,280   | 3,030   | *4,600  | 2,660   | 8.25 m |        |
| -1.5 m   | kg | *6,700   | *6,700  | *11,060   | *11,060   | 11,530  | 6,040   | 7,250   | 4,040   | 5,250   | 3,010   | 5,020   | 2,890   | 7.75 m |        |
| -3.0 m   | kg | *11,730  | *11,730   | *14,650   | 11,700  | *10,550   | 6,120   | 7,310   | 4,090   |   |   | 6,000   | 3,440   | 6.89 m |        |
| -4.5 m   | kg |  |   | *10,860   | *10,860   | *7,950  | 6,370   |   |   |   |   | *5,980  | 4,850   | 5.50 m |        |

| SK210NLC |    | Boom: 5.65 m Arm: 3.50 m Bucket: without Counterweight: 4,300 kg Shoe: 600 mm (Heavy Lift) |   |   |   |   |   |   |   |   |   |   |   |        |
|----------|----|--|---|---|---|---|---|---|---|---|---|---|---|--------|
| B        | A  | 1.5 m  |   | 3.0 m   |   | 4.5 m   |   | 6.0 m   |   | 7.5 m   |   | At max. reach   |   | Radius |
|          |    |           |  |  |  |  |  |  |  |  |  |  |  |        |
| 7.5 m    | kg |  |   |   |   |   |   |   |   |   |   | *3,640  | *3,640  | 6.84 m |
| 6.0 m    | kg |  |   |   |   |   |   |   |   | *4,540  | 3,480   | *3,430  | 3,180   | 7.86 m |
| 4.5 m    | kg |  |   |   |   |   |   | *5,480  | 4,920   | *5,440  | 3,400   | *3,400  | 2,720   | 8.49 m |
| 3.0 m    | kg |  |   | *12,860   | *12,860   | *8,480  | 7,140   | *6,750  | 4,620   | 5,540   | 3,260   | *3,490  | 2,480   | 8.82 m |
| 1.5 m    | kg |  |   | *7,240  | *7,240  | *10,380   | 6,510   | 7,580   | 4,320   | 5,370   | 3,110   | *3,710  | 2,380   | 8.89 m |
| G.L.     | kg |  |   | *7,730  | *7,730  | *11,520   | 6,110   | 7,310   | 4,090   | 5,230   | 2,980   | *4,110  | 2,400   | 8.70 m |
| -1.5 m   | kg | *6,570   | *6,570  | *10,960   | *10,960   | 11,440  | 5,950   | 7,180   | 3,970   | 5,160   | 2,920   | 4,530   | 2,580   | 8.22 m |
| -3.0 m   | kg | *10,480  | *10,480   | *15,820   | 11,410  | *11,000   | 5,970   | 7,170   | 3,970   |   |   | 5,280   | 3,000   | 7.42 m |
| -4.5 m   | kg | *15,580  | *15,580   | *12,690   | 11,780  | *9,090  | 6,150   | *6,410  | 4,130   |   |   | *6,100  | 3,990   | 6.16 m |

| SK210NLC |    | Boom: 5.65 m Arm: 2.40 m Bucket: without Counterweight: 4,300 kg Shoe: 600 mm (Heavy Lift) |   |   |   |   |   |   |   |   |   |        |        |        |
|----------|----|--|---|---|---|---|---|---|---|---|---|--------|--------|--------|
| B        | A  | 3.0 m  |   | 4.5 m   |   | 6.0 m   |   | 7.5 m   |   | At max. reach   |   | Radius |        |        |
|          |    |         |  |  |  |  |  |  |  |  |  |        |        |        |
| 7.5 m    | kg |  |   |   |   |   |   |   |   |   |   | *6,320 | 5,550  | 5.58 m |
| 6.0 m    | kg |  |   |   |   |   |   |   |   |   |   | *5,760 | 3,990  | 6.80 m |
| 4.5 m    | kg |  |   |   |   |   | *6,470  | 4,960   |   |   |   | 5,570  | 3,310  | 7.52 m |
| 3.0 m    | kg |  |   | *8,260  | 7,430   | *6,930  | 4,780   | 5,600   | 3,330   |   |   | 5,070  | 2,990  | 7.89 m |
| 1.5 m    | kg |  |   | *10,100   | 6,810   | *7,700  | 4,520   | 5,510   | 3,250   |   |   | 4,920  | 2,870  | 7.97 m |
| G.L.     | kg |  |   | *11,520   | 6,320   | 7,520   | 4,280   | 5,390   | 3,140   |   |   | 5,070  | 2,940  | 7.75 m |
| -1.5 m   | kg | *11,440  | *11,440   | *11,390   | 6,100   | 7,310   | 4,100   |   |   |   |   | 5,620  | 3,240  | 7.22 m |
| -3.0 m   | kg | *13,150  | 11,920  | *9,880  | 6,240   | *7,190  | 4,210   |   |   |   |   | *6,580 | 3,990  | 6.29 m |
| -4.5 m   | kg |  |   | *6,230  | *6,230  |   |   |   |   |   |   | *5,690 | *5,690 | 4.72 m |

| SK210NLC |    | Boom: 5.65 m Arm: 2.94 m Bucket: without Counterweight: 4,800 kg Shoe: 600 mm (Heavy Lift) |   |   |   |   |   |   |   |   |   |   |   |        |        |
|----------|----|--|---|---|---|---|---|---|---|---|---|---|---|--------|--------|
| B        | A  | 1.5 m  |   | 3.0 m   |   | 4.5 m   |   | 6.0 m   |   | 7.5 m   |   | At max. reach   |   | Radius |        |
|          |    |         |  |  |  |  |  |  |  |  |  |  |  |        |        |
| 7.5 m    | kg |  |   |   |   |   |   | *5,300  | *5,300  |   |   | *4,270  | *4,270  | 6.26 m |        |
| 6.0 m    | kg |  |   |   |   |   |   | *5,880  | 5,390   |   |   | *3,940  | 3,810   | 7.36 m |        |
| 4.5 m    | kg |  |   |   |   |   |   | *6,420  | 5,200   | *5,910  | 3,650   | *3,860  | 3,240   | 8.03 m |        |
| 3.0 m    | kg |  |   |   |   |   | *9,360  | 7,480   | *7,270  | 4,920   | 5,880   | 3,530   | *3,930  | 2,950  | 8.38 m |
| 1.5 m    | kg |  |   |   |   |   | *11,040   | 6,920   | 8,020   | 4,650   | 5,730   | 3,390   | *4,170  | 2,840  | 8.45 m |
| G.L.     | kg |  |   | *6,330  | *6,330  | *11,820   | 6,620   | 7,810   | 4,470   | 5,620   | 3,300   | *4,600  | 2,900   | 8.25 m |        |
| -1.5 m   | kg | *6,700   | *6,700  | *11,060   | *11,060   | *11,650   | 6,540   | 7,720   | 4,390   | 5,600   | 3,270   | 5,350   | 3,140   | 7.75 m |        |
| -3.0 m   | kg | *11,730  | *11,730   | *14,650   | 12,610  | *10,550   | 6,620   | 7,780   | 4,440   |   |   | *6,330  | 3,730   | 6.89 m |        |
| -4.5 m   | kg |  |   | *10,860   | *10,860   | *7,950  | 6,870   |   |   |   |   | *5,980  | 5,230   | 5.50 m |        |

# SK210<sub>LC</sub>

SK210LC-11E

# SK210<sub>NLC</sub>

SK210NLC-11E

# SK210<sub>SNLC</sub>

SK210SNLC-11E

| SK210NLC |    | Boom: 5.65 m Arm: 3.50 m Bucket: without Counterweight: 4,800 kg Shoe: 600 mm (Heavy Lift) |         |         |         |         |       |        |       |        |       |               |        |        |
|----------|----|--|---------|---------|---------|---------|-------|--------|-------|--------|-------|---------------|--------|--------|
| B        | A  | 1.5 m  |         | 3.0 m   |         | 4.5 m   |       | 6.0 m  |       | 7.5 m  |       | At max. reach |        |        |
|          |    |  |         |         |         |         |       |        |       |        |       |               |        | Radius |
| 7.5 m    | kg |  |         |         |         |         |       |        |       |        |       | *3,640        | *3,640 | 6.84 m |
| 6.0 m    | kg |  |         |         |         |         |       |        |       | *4,540 | 3,740 | *3,430        | 3,430  | 7.86 m |
| 4.5 m    | kg |  |         |         |         |         |       | *5,840 | 5,260 | *5,440 | 3,670 | *3,400        | 2,950  | 8.49 m |
| 3.0 m    | kg |  |         | *12,860 | *12,860 | *8,480  | 7,640 | *6,750 | 4,970 | *5,860 | 3,520 | *3,490        | 2,700  | 8.82 m |
| 1.5 m    | kg |  |         | *7,240  | *7,240  | *10,380 | 7,010 | *7,700 | 4,660 | *5,710 | 3,370 | *3,710        | 2,590  | 8.89 m |
| G.L.     | kg |  |         | *7,730  | *7,730  | *11,520 | 6,610 | 7,780  | 4,430 | 5,570  | 3,240 | *4,110        | 2,620  | 8.70 m |
| -1.5 m   | kg | *6,570   | *6,570  | *10,960 | *10,960 | *11,710 | 6,450 | 7,640  | 4,310 | 5,500  | 3,180 | *4,820        | 2,810  | 8.22 m |
| -3.0 m   | kg | *10,480  | *10,480 | *15,820 | 12,330  | *11,000 | 6,470 | 7,640  | 4,310 |        |       | 5,620         | 3,260  | 7.42 m |
| -4.5 m   | kg | *15,580  | *15,580 | *12,690 | *12,690 | *9,090  | 6,650 | *6,410 | 4,470 |        |       | *6,100        | 4,320  | 6.16 m |

| SK210NLC |    | Boom: 5.65 m Arm: 2.40 m Bucket: without Counterweight: 4,800 kg Shoe: 600 mm (Heavy Lift) |         |         |        |        |       |        |       |               |  |        |       |        |
|----------|----|--|---------|---------|--------|--------|-------|--------|-------|---------------|--|--------|-------|--------|
| B        | A  | 3.0 m  |         | 4.5 m   |        | 6.0 m  |       | 7.5 m  |       | At max. reach |  | Radius |       |        |
|          |    |  |         |         |        |        |       |        |       |               |  |        |       |        |
| 7.5 m    | kg |  |         |         |        |        |       |        |       |               |  | *6,320 | 5,920 | 5.58 m |
| 6.0 m    | kg |  |         |         |        | *6,470 | 5,300 |        |       |               |  | *5,760 | 4,280 | 6.80 m |
| 4.5 m    | kg |  |         | *8,260  | 7,930  | *6,930 | 5,130 | *5,850 | 3,600 | *5,610        |  | 3,570  |       | 7.52 m |
| 3.0 m    | kg |  |         | *10,100 | 7,310  | *7,700 | 4,870 | 5,850  | 3,510 | 5,400         |  | 3,240  |       | 7.89 m |
| 1.5 m    | kg |  |         | *11,520 | 6,820  | 7,990  | 4,630 | 5,730  | 3,400 | 5,240         |  | 3,120  |       | 7.97 m |
| G.L.     | kg |  |         | *11,920 | 6,620  | 7,810  | 4,480 | 5,660  | 3,330 | 5,400         |  | 3,200  |       | 7.75 m |
| -1.5 m   | kg | *11,440  | *11,440 | *11,390 | 6,600  | 7,780  | 4,440 |        |       | 5,980         |  | 3,520  |       | 7.22 m |
| -3.0 m   | kg | *13,150  | 12,830  | *9,880  | 6,740  | *7,190 | 4,560 |        |       | *6,580        |  | 4,310  |       | 6.29 m |
| -4.5 m   | kg |  |         | *6,230  | *6,230 |        |       |        |       | *5,690        |  | *5,690 |       | 4.72 m |

| SK210SNLC |    | Boom: 5.65 m Arm: 2.94 m Bucket: without Counterweight: 4,900 kg Shoe: 500 mm (Heavy Lift) |         |         |         |         |       |        |       |        |       |               |        |        |
|-----------|----|--|---------|---------|---------|---------|-------|--------|-------|--------|-------|---------------|--------|--------|
| B         | A  | 1.5 m  |         | 3.0 m   |         | 4.5 m   |       | 6.0 m  |       | 7.5 m  |       | At max. reach |        |        |
|           |    |  |         |         |         |         |       |        |       |        |       |               |        | Radius |
| 7.5 m     | kg |  |         |         |         |         |       | *5,330 | 5,060 |        |       | *4,300        | *4,300 | 6.26 m |
| 6.0 m     | kg |  |         |         |         |         |       | *5,940 | 5,050 |        |       | *3,980        | 3,580  | 7.36 m |
| 4.5 m     | kg |  |         |         |         |         |       | *6,490 | 4,870 | *5,980 | 3,430 | *3,890        | 3,050  | 8.03 m |
| 3.0 m     | kg |  |         |         |         | *9,450  | 6,950 | *7,360 | 4,610 | 5,880  | 3,320 | *3,970        | 2,780  | 8.38 m |
| 1.5 m     | kg |  |         |         |         | *11,150 | 6,430 | 8,030  | 4,350 | 5,740  | 3,190 | *4,200        | 2,680  | 8.45 m |
| G.L.      | kg |  |         | *6,370  | *6,370  | *11,940 | 6,140 | 7,820  | 4,180 | 5,640  | 3,100 | *4,640        | 2,730  | 8.25 m |
| -1.5 m    | kg | *6,730   | *6,730  | *11,090 | *11,090 | *11,770 | 6,060 | 7,730  | 4,100 | 5,610  | 3,070 | 5,370         | 2,950  | 7.75 m |
| -3.0 m    | kg | *11,760  | *11,760 | *14,800 | 11,460  | *10,660 | 6,140 | 7,780  | 4,150 |        |       | 6,400         | 3,500  | 6.89 m |
| -4.5 m    | kg |  |         | *11,000 | *11,000 | *8,060  | 6,370 |        |       |        |       | *6,070        | 4,880  | 5.50 m |

| SK210SNLC |    | Boom: 5.65 m Arm: 2.40 m Bucket: without Counterweight: 4,900 kg Shoe: 500 mm (Heavy Lift) |         |         |        |        |       |        |       |               |  |        |       |        |
|-----------|----|--|---------|---------|--------|--------|-------|--------|-------|---------------|--|--------|-------|--------|
| B         | A  | 3.0 m  |         | 4.5 m   |        | 6.0 m  |       | 7.5 m  |       | At max. reach |  | Radius |       |        |
|           |    |  |         |         |        |        |       |        |       |               |  |        |       |        |
| 7.5 m     | kg |  |         |         |        |        |       |        |       |               |  | *6,370 | 5,570 | 5.58 m |
| 6.0 m     | kg |  |         |         |        | *6,570 | 4,990 |        |       |               |  | *5,800 | 4,050 | 6.80 m |
| 4.5 m     | kg |  |         | *8,380  | 7,400  | *7,030 | 4,830 | *5,890 | 3,410 | *5,650        |  | 3,390  |       | 7.52 m |
| 3.0 m     | kg |  |         | *10,230 | 6,830  | *7,820 | 4,590 | 5,890  | 3,330 | 5,430         |  | 3,070  |       | 7.89 m |
| 1.5 m     | kg |  |         | *11,680 | 6,370  | 8,020  | 4,360 | 5,770  | 3,220 | 5,280         |  | 2,960  |       | 7.97 m |
| G.L.      | kg |  |         | *12,080 | 6,180  | 7,860  | 4,220 | 5,700  | 3,160 | 5,440         |  | 3,030  |       | 7.75 m |
| -1.5 m    | kg | *11,480  | *11,480 | *11,550 | 6,160  | 7,820  | 4,190 |        |       | 6,020         |  | 3,330  |       | 7.22 m |
| -3.0 m    | kg | *13,350  | 11,720  | *10,030 | 6,290  | *7,310 | 4,290 |        |       | *6,700        |  | 4,060  |       | 6.29 m |
| -4.5 m    | kg |  |         | *6,360  | *6,360 |        |       |        |       | *5,820        |  | *5,820 |       | 4.72 m |

**Notes:**

- Do not attempt to lift or hold any load that is greater than these lift capacities at their specified lift point radius and heights. Weight of all accessories must be deducted from the above lift capacities.
- Lift capacities are based on machine standing on level, firm, and uniform ground. User must make allowance for job conditions such as soft or uneven ground, out of level conditions, side loads, sudden stopping of loads, hazardous conditions, experience of personnel, etc.
- Arm top defined as lift point.
- The above lift capacities are in compliance with ISO 10567. They do not exceed 87% of hydraulic lift capacity or 75% of tipping load. Lift capacities marked with an asterisk (\*) are limited by hydraulic capacity rather than tipping load.
- Operator should be fully acquainted with the Operator's and Maintenance Instructions before operating this machine. Rules for safe operation of equipment should be adhered to at all times.
- Lift capacities apply to only machine as originally manufactured and normally equipped by KOBELCO CONSTRUCTION MACHINERY CO., LTD.

# 2 Piece Boom Specifications

## Working ranges

Unit: mm

| Boom                                      |   | 2 Piece boom    |                    |                |
|---|---|-----------------|--------------------|----------------|
| Arm                                       |   | Short<br>2.40 m | Standard<br>2.94 m | Long<br>3.50 m |
| a-  | Max. digging reach                        | 9,570           | 10,070             | 10,530         |
| b-  | Max. digging reach at ground level        | 9,390           | 9,900              | 10,370         |
| c-  | Max. digging depth                        | 5,890           | 6,420              | 6,930          |
| d-  | Max. digging height                       | 10,830          | 11,230             | 11,500         |
| e-  | Max. dumping clearance                    | 7,950           | 8,350              | 8,620          |
| f-  | Min. dumping clearance                    | 1,510           | 970                | 410            |
| g-  | Max. vertical wall digging depth          | 5,070           | 5,580              | 6,020          |
| h-  | Min. swing radius                         | 2,760           | 2,550              | 2,720          |
| i-  | Horizontal digging stroke at ground level | 5,770           | 6,800              | 7,800          |
| j-  | Digging depth for 2.4 m (8') flat bottom  | 5,780           | 6,310              | 6,830          |
| Bucket capacity ISO heaped m <sup>3</sup> |   | 0.93            | 0.80               | 0.70           |

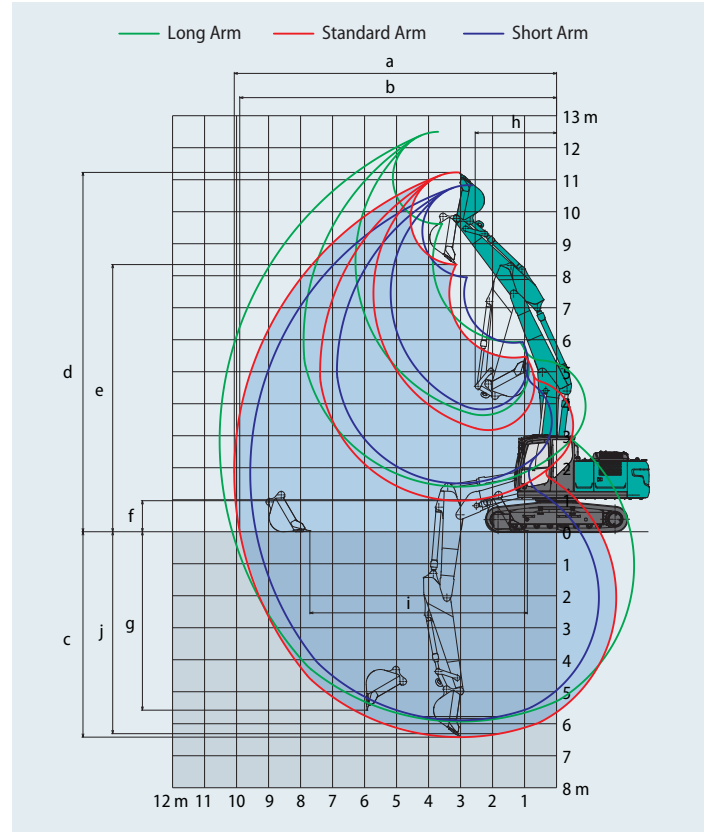

## Digging Force (ISO 6015)

Unit: kN

| Arm length           | Short<br>2.40 m | Standard<br>2.94 m | Long<br>3.50 m |
|----------------------|-----------------|--------------------|----------------|
| Bucket digging force | 143<br>157*     | 143<br>157*        | 143<br>157*    |
| Arm crowding force   | 121<br>133*     | 102<br>112*        | 91.8<br>101*   |

\*Power Boost engaged.

## Dimensions (SK210LC/SK210NLC)

Unit: mm

| Arm length |   | Short<br>2.40 m | Standard<br>2.94 m | Long<br>3.50 m |
|------------|---|-----------------|--------------------|----------------|
| A          | Overall length                            | 9,760           | 9,740              | 9,730          |
| B          | Overall height (to top of boom)           | 3,030           | 2,970              | 3,280          |
| C          | Overall width of crawler                  | SK210LC         | 2,990              |                |
|            |   | SK210NLC        | 2,800              |                |
| D          | Overall height (to top of cab)            | 3,060           |                    |                |
| E          | Ground clearance of rear end*             | 1,060           |                    |                |
| F          | Ground clearance*                         | 425             |                    |                |
| G          | Tail swing radius                         | 2,910           |                    |                |
| G'         | Distance from centre of swing to rear end | 2,900           |                    |                |
| H          | Tumbler distance                          | 3,660           |                    |                |
| I          | Overall length of crawler                 | 4,450           |                    |                |
| J          | Track gauge                               | SK210LC         | 2,390              |                |
|            |   | SK210NLC        | 2,200              |                |
| K          | Shoe width                                | 600             |                    |                |
| L          | Overall width of upperstructure           | 2,710           |                    |                |

\*Without including height of shoe

## Dimensions (SK210SNLC)

Unit: mm

| Arm length |   | Short<br>2.40 m | Standard<br>2.94 m |
|------------|---|-----------------|--------------------|
| A          | Overall length                            | 9,660           | 9,640              |
| B          | Overall height (to top of boom)           | 3,030           | 2,970              |
| C          | Overall width of crawler                  | 2,540           |                    |
| D          | Overall height (to top of cab)            | 3,060           |                    |
| E          | Ground clearance of rear end*             | 1,050           |                    |
| F          | Ground clearance*                         | 425             |                    |
| G          | Tail swing radius                         | 2,800           |                    |
| G'         | Distance from centre of swing to rear end | 2,800           |                    |
| H          | Tumbler distance                          | 3,660           |                    |
| I          | Overall length of crawler                 | 4,450           |                    |
| J          | Track gauge                               | 2,040           |                    |
| K          | Shoe width                                | 500             |                    |
| L          | Overall width of upperstructure           | 2,540           |                    |

\*Without including height of shoe

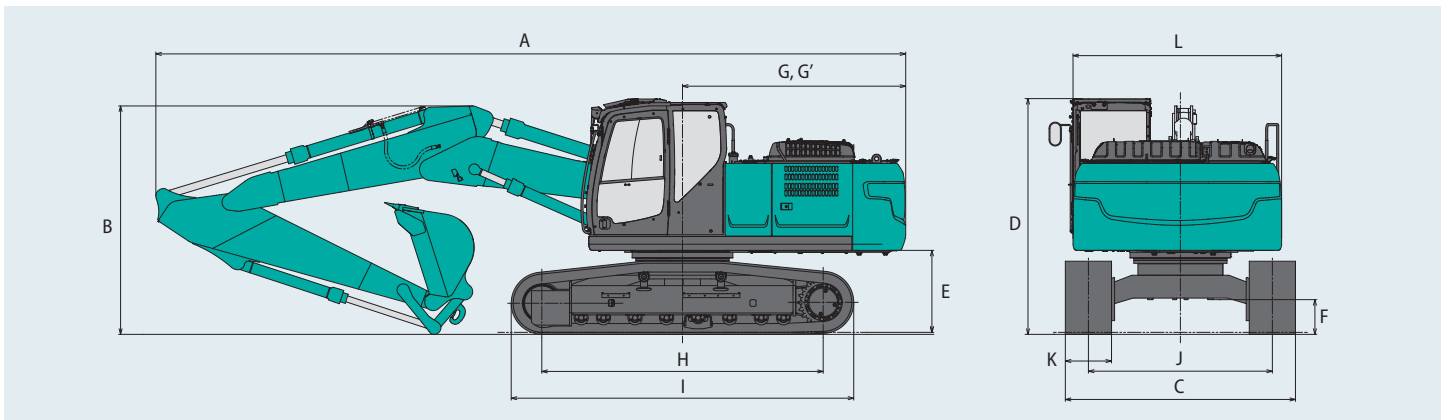

## Operating weight & ground pressure

In standard trim, with 2 Piece boom, 2.94 m arm, and 0.8 m<sup>3</sup> ISO heaped bucket.

| Shaped                   |           |     | Triple grouser shoes (even height) |        |        |        |        |
|--------------------------|-----------|-----|------------------------------------|--------|--------|--------|--------|
| Shoe width               |           |     | 500                                | 600    | 700    | 790    | 900    |
| Overall width of crawler | SK210LC   | mm  | —                                  | 2,990  | 3,090  | 3,180  | 3,290  |
|                          | SK210NLC  | mm  | —                                  | 2,800  | 2,900  | 2,990  | —      |
|                          | SK210SNLC | mm  | 2,540                              | 2,640  | —      | —      | —      |
| Ground pressure          | SK210LC   | kPa | —                                  | 48     | 42     | 38     | 33     |
|                          | SK210NLC  | kPa | —                                  | 48     | 42     | 37     | —      |
|                          | SK210SNLC | kPa | 59                                 | 49     | —      | —      | —      |
| Operating weight         | SK210LC   | kg  | —                                  | 23,100 | 23,600 | 23,800 | 24,100 |
|                          | SK210NLC  | kg  | —                                  | 23,000 | 23,500 | 23,700 | —      |
|                          | SK210SNLC | kg  | 23,500                             | 23,700 | —      | —      | —      |

In standard trim, with 2 Piece boom, 2.94 m arm, and 0.8 m<sup>3</sup> ISO heaped bucket (optional counterweight 4,800 kg).

| Shaped                   |          |     | Triple grouser shoes (even height) |        |        |        |
|--------------------------|----------|-----|------------------------------------|--------|--------|--------|
| Shoe width               |          |     | 600                                | 700    | 790    | 900    |
| Overall width of crawler | SK210LC  | mm  | 2,990                              | 3,090  | 3,180  | 3,290  |
|                          | SK210NLC | mm  | 2,800                              | 2,900  | 2,990  | —      |
| Ground pressure          | SK210LC  | kPa | 49                                 | 43     | 38     | 34     |
|                          | SK210NLC | kPa | 49                                 | 40     | 36     | —      |
| Operating weight         | SK210LC  | kg  | 23,600                             | 24,100 | 24,300 | 24,600 |
|                          | SK210NLC | kg  | 23,500                             | 24,000 | 24,200 | —      |

## Lift capacities

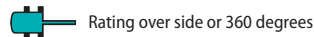
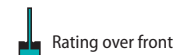
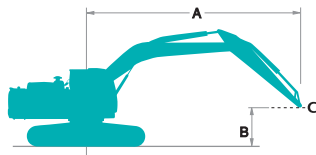

A - Reach from swing centerline to arm top













B - Arm top height above/below ground













C - Lift point













Relief valve setting: 37.8 MPa













| SK210LC |    | 2 Piece boom |         | Arm: 2.94 m |         | Bucket: without |        | Counterweight: 4,300 kg |        | Shoe: 600 mm (Heavy Lift) |       |               |        |        |
|---------|----|--------------|---------|-------------|---------|-----------------|--------|-------------------------|--------|---------------------------|-------|---------------|--------|--------|
| B       | A  | 1.5 m        |         | 3.0 m       |         | 4.5 m           |        | 6.0 m                   |        | 7.5 m                     |       | At max. reach |        |        |
|         |    |              |         |             |         |                 |        |                         |        |                           |       |               |        | Radius |
| 9.0 m   | kg |              |         |             |         | *5,880          | *5,880 |                         |        |                           |       | *4,930        | *4,930 | 4.74 m |
| 7.5 m   | kg |              |         |             |         | *6,770          | *6,770 | *5,680                  | 5,440  |                           |       | *4,040        | *4,040 | 6.49 m |
| 6.0 m   | kg |              |         |             |         | *6,870          | *6,870 | *4,620                  | *4,620 | *4,100                    | 3,600 | *3,700        | 3,550  | 7.55 m |
| 4.5 m   | kg |              |         | *10,460     | *10,460 | *9,180          | 8,220  | *7,630                  | 5,170  | *4,820                    | 3,560 | *3,580        | 3,000  | 8.21 m |
| 3.0 m   | kg | *31,510      | *31,510 | *16,370     | 14,230  | *10,810         | 7,440  | 7,780                   | 4,830  | *4,780                    | 3,410 | *3,610        | 2,720  | 8.55 m |
| 1.5 m   | kg |              |         | *17,860     | 12,690  | *11,550         | 6,750  | 7,410                   | 4,500  | *5,140                    | 3,250 | *3,770        | 2,620  | 8.62 m |
| G.L.    | kg | *19,950      | *19,950 | *14,860     | 12,300  | *11,200         | 6,410  | 7,160                   | 4,280  | 5,140                     | 3,140 | *4,100        | 2,670  | 8.42 m |
| -1.5 m  | kg |              |         | *10,000     | *10,000 | *9,830          | 6,330  | 7,070                   | 4,200  | 5,120                     | 3,110 | *4,690        | 2,910  | 7.93 m |
| -3.0 m  | kg |              |         | *8,590      | *8,590  | *7,430          | 6,450  | *5,640                  | 4,270  |                           |       | *3,780        | 3,460  | 7.10 m |
| -4.5 m  | kg |              |         | *11,920     | *11,920 | *6,720          | *6,720 |                         |        |                           |       | *1,810        | *1,810 | 5.76 m |

| SK210LC |    | 2 Piece boom |         | Arm: 3.50 m |         | Bucket: without |        | Counterweight: 4,300 kg |        | Shoe: 600 mm (Heavy Lift) |       |        |        |               |
|---------|----|--------------|---------|-------------|---------|-----------------|--------|-------------------------|--------|---------------------------|-------|--------|--------|---------------|
| B       | A  | 1.5 m        |         | 3.0 m       |         | 4.5 m           |        | 6.0 m                   |        | 7.5 m                     |       | 9.0 m  |        | At max. reach |
|         |    |              |         |             |         |                 |        |                         |        |                           |       |        |        | Radius        |
| 9.0 m   | kg |              |         |             |         | *5,740          | *5,740 |                         |        |                           |       | *4,030 | *4,030 | 5.53 m        |
| 7.5 m   | kg |              |         |             |         |                 |        | *4,890                  | *4,890 |                           |       | *3,460 | *3,460 | 7.09 m        |
| 6.0 m   | kg |              |         |             |         |                 |        | *5,890                  | 5,520  | *4,460                    | 3,700 | *3,240 | 3,180  | 8.07 m        |
| 4.5 m   | kg |              |         |             |         | *6,900          | *6,900 | *6,880                  | 5,270  | *4,150                    | 3,600 | *3,170 | 2,720  | 8.69 m        |
| 3.0 m   | kg | *27,450      | *27,450 | *15,750     | 14,900  | *10,210         | 7,660  | *7,810                  | 4,900  | *4,070                    | 3,420 | *3,330 | 2,490  | 9.01 m        |
| 1.5 m   | kg | *18,250      | *18,250 | *17,840     | 13,000  | *11,280         | 6,880  | 7,450                   | 4,530  | *4,400                    | 3,240 | *3,890 | 2,410  | 9.08 m        |
| G.L.    | kg | *19,130      | *19,130 | *6,700      | *6,700  | *11,360         | 6,410  | 7,140                   | 4,260  | 5,100                     | 3,090 | *3,710 | 2,400  | 8.89 m        |
| -1.5 m  | kg |              |         | *9,990      | *9,990  | *10,390         | 6,230  | 6,990                   | 4,120  | 5,020                     | 3,020 | *4,220 | 2,580  | 8.43 m        |
| -3.0 m  | kg |              |         | *10,660     | *10,660 | *8,420          | 6,280  | *6,380                  | 4,130  | *4,300                    | 3,070 | *4,000 | 3,000  | 7.65 m        |
| -4.5 m  | kg |              |         | *14,570     | 13,100  | *5,130          | *5,130 | *4,490                  | 4,340  |                           |       | *2,700 | *2,700 | 6.43 m        |

| SK210LC |    | 2 Piece boom |   | Arm: 2.40 m   |   | Bucket: without   |   | Counterweight: 4,300 kg   |   | Shoe: 600 mm (Heavy Lift)   |   | At max. reach   |   | Radius  |        |
|---------|----|--------------|---|---|---|---|---|---|---|---|---|---|---|---|--------|
| B       | A  | 1.5 m        |   | 3.0 m   |   | 4.5 m   |   | 6.0 m   |   | 7.5 m   |   | At max. reach   |   |   |        |
|         |    |              |  |  |  |  |  |  |  |  |  |  |  |  |        |
| 9.0 m   | kg |              |   |   |   |   |   |   |   |   |   |   | *7,980  | *7,980  | 3.73 m |
| 7.5 m   | kg |              |   |   |   | *8,830  | 8,770   |   |   |   |   |   | *6,060  | 5,550   | 5.80 m |
| 6.0 m   | kg |              |   |   |   | *9,000  | 8,570   | *5,580  | 5,290   |   |   |   | *5,130  | 4,010   | 6.97 m |
| 4.5 m   | kg |              |   | *14,150   | *14,150   | *10,110   | 7,990   | *4,770  | *4,770  | *5,240  | 3,490   |   | *4,720  | 3,330   | 7.68 m |
| 3.0 m   | kg |              |   | *15,800   | 14,260  | *11,250   | 7,210   | 7,690   | 4,750   | 5,400   | 3,380   |   | *4,580  | 3,000   | 8.05 m |
| 1.5 m   | kg |              |   | *17,890   | 12,860  | *11,600   | 6,630   | 7,360   | 4,460   | 5,260   | 3,250   |   | *4,650  | 2,890   | 8.12 m |
| G.L.    | kg | *25,320      | *25,320   | *15,660   | 12,430  | *10,800   | 6,400   | 7,160   | 4,290   | 5,180   | 3,170   |   | 4,810   | 2,960   | 7.91 m |
| -1.5 m  | kg |              |   | *9,810  | *9,810  | *9,050  | 6,410   | *7,020  | 4,260   |   |   |   | *4,810  | 3,270   | 7.39 m |
| -3.0 m  | kg |              |   |   |   | *6,250  | *6,250  | *4,580  | 4,400   |   |   |   | *3,540  | *3,540  | 6.48 m |

| SK210LC |    | 2 Piece boom |   | Arm: 2.94 m   |   | Bucket: without   |   | Counterweight: 4,800 kg   |   | Shoe: 600 mm (Heavy Lift)   |   | At max. reach   |   | Radius  |        |
|---------|----|--------------|---|---|---|---|---|---|---|---|---|---|---|---|--------|
| B       | A  | 1.5 m        |   | 3.0 m   |   | 4.5 m   |   | 6.0 m   |   | 7.5 m   |   | At max. reach   |   |   |        |
|         |    |              |  |  |  |  |  |  |  |  |  |  |  |  |        |
| 9.0 m   | kg |              |   |   |   | *5,880  | *5,880  |   |   |   |   |   | *4,930  | *4,930  | 4.74 m |
| 7.5 m   | kg |              |   |   |   | *6,770  | *6,770  | *5,680  | *5,680  |   |   |   | *4,040  | *4,040  | 6.49 m |
| 6.0 m   | kg |              |   |   |   | *6,870  | *6,870  | *4,620  | *4,620  | *4,100  | 3,880   |   | *3,700  | *3,700  | 7.55 m |
| 4.5 m   | kg |              |   | *10,460   | *10,460   | *9,180  | 8,750   | *7,630  | 5,530   | *4,820  | 3,830   |   | *3,580  | 3,520   | 8.21 m |
| 3.0 m   | kg | *31,510      | *31,510   | *16,370   | 15,220  | *10,810   | 7,960   | *8,150  | 5,190   | *4,780  | 3,680   |   | *3,610  | 2,960   | 8.55 m |
| 1.5 m   | kg |              |   | *17,860   | 13,680  | *11,550   | 7,280   | 7,880   | 4,860   | *5,140  | 3,520   |   | *3,770  | 2,850   | 8.62 m |
| G.L.    | kg | *19,950      | *19,950   | *14,860   | 13,290  | *11,200   | 6,940   | 7,630   | 4,640   | 5,490   | 3,410   |   | *4,100  | 2,910   | 8.42 m |
| -1.5 m  | kg |              |   | *10,000   | *10,000   | *9,830  | 6,860   | *7,480  | 4,560   | 5,460   | 3,390   |   | *4,690  | 3,160   | 7.93 m |
| -3.0 m  | kg |              |   | *8,590  | *8,590  | *7,430  | 6,980   | *5,640  | 4,630   |   |   |   | *3,780  | 3,750   | 7.10 m |
| -4.5 m  | kg |              |   | *11,920   | *11,920   | *6,720  | *6,720  |   |   |   |   |   | *1,810  | *1,810  | 5.76 m |

| SK210LC |    | 2 Piece boom |   | Arm: 3.50 m   |   | Bucket: without   |   | Counterweight: 4,800 kg   |   | Shoe: 600 mm (Heavy Lift)   |   | At max. reach   |   | Radius  |        |        |
|---------|----|--------------|---|---|---|---|---|---|---|---|---|---|---|---|--------|--------|
| B       | A  | 1.5 m        |   | 3.0 m   |   | 4.5 m   |   | 6.0 m   |   | 7.5 m   |   | 9.0 m   |   |   |        |        |
|         |    |              |  |  |  |  |  |  |  |  |  |  |  |  |        |        |
| 9.0 m   | kg |              |   |   |   | *5,740  | *5,740  |   |   |   |   |   | *4,030  | *4,030  | 5.53 m |        |
| 7.5 m   | kg |              |   |   |   |   |   | *4,890  | *4,890  |   |   |   | *3,460  | *3,460  | 7.09 m |        |
| 6.0 m   | kg |              |   |   |   |   |   | *5,890  | 5,880   | *4,460  | 3,970   |   | *3,240  | *3,240  | 8.07 m |        |
| 4.5 m   | kg |              |   |   |   | *6,900  | *6,900  | *6,880  | 5,630   | *4,150  | 3,870   |   | *3,170  | 2,950   | 8.69 m |        |
| 3.0 m   | kg | *27,450      | *27,450   | *15,750   | *15,750   | *10,210   | 8,190   | *7,810  | 5,260   | *4,070  | 3,700   | *3,330  | 2,710   | *3,230  | 2,700  | 9.01 m |
| 1.5 m   | kg | *18,250      | *18,250   | *17,840   | 13,990  | *11,280   | 7,410   | 7,920   | 4,890   | *4,400  | 3,510   | *3,890  | 2,630   | *3,390  | 2,600  | 9.08 m |
| G.L.    | kg | *19,130      | *19,130   | *6,700  | *6,700  | *11,360   | 6,930   | 7,610   | 4,620   | *5,180  | 3,360   |   | *3,710  | 2,630   | 8.89 m |        |
| -1.5 m  | kg |              |   | *9,990  | *9,990  | *10,390   | 6,760   | 7,460   | 4,480   | 5,370   | 3,290   |   | *4,220  | 2,820   | 8.43 m |        |
| -3.0 m  | kg |              |   | *10,660   | *10,660   | *8,420  | 6,810   | *6,380  | 4,490   | *4,300  | 3,350   |   | *4,000  | 3,270   | 7.65 m |        |
| -4.5 m  | kg |              |   | *14,570   | 14,090  | *5,130  | *5,130  | *4,490  | *4,490  |   |   |   | *2,700  | *2,700  | 6.43 m |        |

| SK210LC |    | 2 Piece boom |   | Arm: 2.40 m   |   | Bucket: without   |   | Counterweight: 4,800 kg   |   | Shoe: 600 mm (Heavy Lift)   |   | At max. reach   |   | Radius  |        |
|---------|----|--------------|---|---|---|---|---|---|---|---|---|---|---|---|--------|
| B       | A  | 1.5 m        |   | 3.0 m   |   | 4.5 m   |   | 6.0 m   |   | 7.5 m   |   | At max. reach   |   |   |        |
|         |    |              |  |  |  |  |  |  |  |  |  |  |  |  |        |
| 9.0 m   | kg |              |   |   |   |   |   |   |   |   |   |   | *7,980  | *7,980  | 3.73 m |
| 7.5 m   | kg |              |   |   |   | *8,830  | *8,830  |   |   |   |   |   | *6,060  | 5,920   | 5.80 m |
| 6.0 m   | kg |              |   |   |   | *9,000  | *9,000  | *5,580  | *5,580  |   |   |   | *5,130  | 4,310   | 6.97 m |
| 4.5 m   | kg |              |   | *14,150   | *14,150   | *10,110   | 8,520   | *4,770  | *4,770  | *5,240  | 3,760   |   | *4,720  | 3,600   | 7.68 m |
| 3.0 m   | kg |              |   | *15,800   | 15,250  | *11,250   | 7,740   | 8,150   | 5,110   | *5,500  | 3,650   |   | *4,580  | 3,250   | 8.05 m |
| 1.5 m   | kg |              |   | *17,890   | 13,850  | *11,600   | 7,160   | 7,830   | 4,820   | 5,610   | 3,520   |   | *4,650  | 3,140   | 8.12 m |
| G.L.    | kg | *25,320      | *25,320   | *15,660   | 13,420  | *10,800   | 6,930   | 7,630   | 4,650   | 5,520   | 3,450   |   | *4,930  | 3,220   | 7.91 m |
| -1.5 m  | kg |              |   | *9,810  | *9,810  | *9,050  | 6,940   | *7,020  | 4,620   |   |   |   | *4,810  | 3,550   | 7.39 m |
| -3.0 m  | kg |              |   |   |   | *6,250  | *6,250  | *4,580  | *4,580  |   |   |   | *3,540  | *3,540  | 6.48 m |

# SK210<sup>LC</sup>

SK210LC-11E

# SK210<sup>NLC</sup>

SK210NLC-11E

# SK210<sup>SNLC</sup>

SK210SNLC-11E

| SK210NLC |    | 2 Piece boom |         | Arm: 2.94 m |         | Bucket: without |        | Counterweight: 4,300 kg |        | Shoe: 600 mm (Heavy Lift) |       |               |        |        |
|----------|----|--------------|---------|-------------|---------|-----------------|--------|-------------------------|--------|---------------------------|-------|---------------|--------|--------|
| B        | A  | 1.5 m        |         | 3.0 m       |         | 4.5 m           |        | 6.0 m                   |        | 7.5 m                     |       | At max. reach |        | Radius |
|          |    |              |         |             |         |                 |        |                         |        |                           |       |               |        |        |
| 9.0 m    | kg |              |         |             |         | *5,880          | *5,880 |                         |        |                           |       | *4,930        | *4,930 | 4.74 m |
| 7.5 m    | kg |              |         |             |         | *6,770          | *6,770 | *5,680                  | 5,000  |                           |       | *4,040        | *4,040 | 6.49 m |
| 6.0 m    | kg |              |         |             |         | *6,870          | *6,870 | *4,620                  | *4,620 | *4,100                    | 3,290 | *3,700        | 3,240  | 7.55 m |
| 4.5 m    | kg |              |         | *10,460     | *10,460 | *9,180          | 7,500  | *7,630                  | 4,730  | *4,820                    | 3,250 | *3,580        | 2,730  | 8.21 m |
| 3.0 m    | kg | *31,510      | *31,510 | *16,370     | 12,600  | *10,810         | 6,730  | 7,760                   | 4,400  | *4,780                    | 3,100 | *3,610        | 2,470  | 8.55 m |
| 1.5 m    | kg |              |         | *17,860     | 11,140  | *11,550         | 6,070  | 7,390                   | 4,070  | *5,140                    | 2,940 | *3,770        | 2,370  | 8.62 m |
| G.L.     | kg | *19,950      | *19,950 | *14,860     | 10,760  | *11,200         | 5,730  | 7,140                   | 3,860  | 5,130                     | 2,830 | *4,100        | 2,410  | 8.42 m |
| -1.5 m   | kg |              |         | *10,000     | *10,000 | *9,830          | 5,660  | 7,050                   | 3,780  | 5,100                     | 2,810 | *4,690        | 2,630  | 7.93 m |
| -3.0 m   | kg |              |         | *8,590      | *8,590  | *7,430          | 5,770  | *5,640                  | 3,850  |                           |       | *3,780        | 3,130  | 7.10 m |
| -4.5 m   | kg |              |         | *11,920     | 11,800  | *6,720          | 6,140  |                         |        |                           |       | *1,810        | *1,810 | 5.76 m |

| SK210NLC |    | 2 Piece boom |         | Arm: 3.50 m |         | Bucket: without |        | Counterweight: 4,300 kg |        | Shoe: 600 mm (Heavy Lift) |       |        |       |               |        |        |
|----------|----|--------------|---------|-------------|---------|-----------------|--------|-------------------------|--------|---------------------------|-------|--------|-------|---------------|--------|--------|
| B        | A  | 1.5 m        |         | 3.0 m       |         | 4.5 m           |        | 6.0 m                   |        | 7.5 m                     |       | 9.0 m  |       | At max. reach |        |        |
|          |    |              |         |             |         |                 |        |                         |        |                           |       |        |       |               |        |        |
| 9.0 m    | kg |              |         |             |         | *5,740          | *5,740 |                         |        |                           |       |        |       | *4,030        | *4,030 | 5.53 m |
| 7.5 m    | kg |              |         |             |         |                 |        | *4,890                  | *4,890 |                           |       |        |       | *3,460        | *3,460 | 7.09 m |
| 6.0 m    | kg |              |         |             |         |                 |        | *5,890                  | 5,070  | *4,460                    | 3,390 |        |       | *3,240        | 2,900  | 8.07 m |
| 4.5 m    | kg |              |         |             |         | *6,900          | *6,900 | *6,880                  | 4,820  | *4,150                    | 3,290 |        |       | *3,170        | 2,470  | 8.69 m |
| 3.0 m    | kg | *27,450      | *27,450 | *15,750     | 13,230  | *10,210         | 6,950  | *7,810                  | 4,460  | *4,070                    | 3,120 | *3,330 | 2,250 | *3,230        | 2,240  | 9.01 m |
| 1.5 m    | kg | *18,250      | *18,250 | *17,840     | 11,430  | *11,280         | 6,190  | 7,440                   | 4,100  | *4,400                    | 2,930 | *3,890 | 2,180 | *3,390        | 2,140  | 9.08 m |
| G.L.     | kg | *19,130      | *19,130 | *6,700      | *6,700  | 11,330          | 5,730  | 7,130                   | 3,830  | 5,090                     | 2,780 |        |       | *3,710        | 2,160  | 8.89 m |
| -1.5 m   | kg |              |         | *9,990      | *9,990  | *10,390         | 5,560  | 6,970                   | 3,700  | 5,010                     | 2,720 |        |       | *4,220        | 2,330  | 8.43 m |
| -3.0 m   | kg |              |         | *10,660     | *10,660 | *8,420          | 5,610  | *6,380                  | 3,710  | *4,300                    | 2,770 |        |       | *4,000        | 2,710  | 7.65 m |
| -4.5 m   | kg |              |         | *14,570     | 11,520  | *5,130          | *5,130 | *4,490                  | 3,910  |                           |       |        |       | *2,700        | *2,700 | 6.43 m |















| SK210NLC |    | 2 Piece boom |         | Arm: 2.40 m |         | Bucket: without |       | Counterweight: 4,300 kg |       | Shoe: 600 mm (Heavy Lift) |       |               |       |        |        |        |
|----------|----|--------------|---------|-------------|---------|-----------------|-------|-------------------------|-------|---------------------------|-------|---------------|-------|--------|--------|--------|
| B        | A  | 1.5 m        |         | 3.0 m       |         | 4.5 m           |       | 6.0 m                   |       | 7.5 m                     |       | At max. reach |       | Radius |        |        |
|          |    |              |         |             |         |                 |       |                         |       |                           |       |               |       |        |        |        |
| 9.0 m    | kg |              |         |             |         |                 |       |                         |       |                           |       |               |       | *7,980 | *7,980 | 3.73 m |
| 7.5 m    | kg |              |         |             |         | *8,830          | 8,040 |                         |       |                           |       |               |       | *6,060 | 5,080  | 5.80 m |
| 6.0 m    | kg |              |         |             |         | *9,000          | 7,840 | *5,580                  | 4,850 |                           |       |               |       | *5,130 | 3,670  | 6.97 m |
| 4.5 m    | kg |              |         | *14,150     | *14,150 | *10,110         | 7,270 | *4,770                  | 4,630 | *5,240                    | 3,180 | *4,720        | 3,030 | *4,720 | 3,030  | 7.68 m |
| 3.0 m    | kg |              |         | *15,800     | 12,620  | *11,250         | 6,520 | 7,670                   | 4,320 | 5,390                     | 3,070 | *4,580        | 2,730 | *4,580 | 2,730  | 8.05 m |
| 1.5 m    | kg |              |         | *17,890     | 11,300  | 11,580          | 5,950 | 7,340                   | 4,040 | 5,250                     | 2,940 | *4,650        | 2,620 | *4,650 | 2,620  | 8.12 m |
| G.L.     | kg | *25,320      | *25,320 | *15,660     | 10,890  | *10,800         | 5,730 | 7,150                   | 3,870 | 5,170                     | 2,870 | 4,800         | 2,680 | 4,800  | 2,680  | 7.91 m |
| -1.5 m   | kg |              |         | *9,810      | *9,810  | *9,050          | 5,740 | *7,020                  | 3,840 |                           |       |               |       | *4,810 | 2,960  | 7.39 m |
| -3.0 m   | kg |              |         |             |         | *6,250          | 5,920 | *4,580                  | 3,980 |                           |       |               |       | *3,540 | *3,540 | 6.48 m |















| SK210NLC |    | 2 Piece boom |         | Arm: 2.94 m |         | Bucket: without |        | Counterweight: 4,800 kg |        | Shoe: 600 mm (Heavy Lift) |       |               |       |        |        |        |
|----------|----|--------------|---------|-------------|---------|-----------------|--------|-------------------------|--------|---------------------------|-------|---------------|-------|--------|--------|--------|
| B        | A  | 1.5 m        |         | 3.0 m       |         | 4.5 m           |        | 6.0 m                   |        | 7.5 m                     |       | At max. reach |       | Radius |        |        |
|          |    |              |         |             |         |                 |        |                         |        |                           |       |               |       |        |        |        |
| 9.0 m    | kg |              |         |             |         | *5,880          | *5,880 |                         |        |                           |       |               |       | *4,930 | *4,930 | 4.74 m |
| 7.5 m    | kg |              |         |             |         | *6,770          | *6,770 | *5,680                  | 5,340  |                           |       |               |       | *4,040 | *4,040 | 6.49 m |
| 6.0 m    | kg |              |         |             |         | *6,870          | *6,870 | *4,620                  | *4,620 | *4,100                    | 3,560 |               |       | *3,700 | 3,500  | 7.55 m |
| 4.5 m    | kg |              |         | *10,460     | *10,460 | *9,180          | 8,000  | *7,630                  | 5,080  | *4,820                    | 3,510 | *3,580        | 2,970 | *3,580 | 2,970  | 8.21 m |
| 3.0 m    | kg | *31,510      | *31,510 | *16,370     | 13,510  | *10,810         | 7,230  | *8,150                  | 4,740  | *4,780                    | 3,360 | *3,610        | 2,690 | *3,610 | 2,690  | 8.55 m |
| 1.5 m    | kg |              |         | *17,860     | 12,050  | *11,550         | 6,570  | 7,860                   | 4,420  | *5,140                    | 3,210 | *3,770        | 2,590 | *3,770 | 2,590  | 8.62 m |
| G.L.     | kg | *19,950      | *19,950 | *14,860     | 11,680  | *11,200         | 6,230  | 7,610                   | 4,200  | 5,470                     | 3,090 | *4,100        | 2,640 | *4,100 | 2,640  | 8.42 m |
| -1.5 m   | kg |              |         | *10,000     | *10,000 | *9,830          | 6,160  | *7,480                  | 4,120  | 5,450                     | 3,070 | *4,690        | 2,870 | *4,690 | 2,870  | 7.93 m |
| -3.0 m   | kg |              |         | *8,590      | *8,590  | *7,430          | 6,270  | *5,640                  | 4,190  |                           |       |               |       | *3,780 | 3,410  | 7.10 m |
| -4.5 m   | kg |              |         | *11,920     | *11,920 | *6,720          | 6,640  |                         |        |                           |       |               |       | *1,810 | *1,810 | 5.76 m |















**Notes:**















- Do not attempt to lift or hold any load that is greater than these lift capacities at their specified lift point radius and heights. Weight of all accessories must be deducted from the above lift capacities.
- Lift capacities are based on machine standing on level, firm, and uniform ground. User must make allowance for job conditions such as soft or uneven ground, out of level conditions, side loads, sudden stopping of loads, hazardous conditions, experience of personnel, etc.
- Arm top defined as lift point.
- The above lift capacities are in compliance with ISO 10567. They do not exceed 87% of hydraulic lift

- capacity or 75% of tipping load. Lift capacities marked with an asterisk (\*) are limited by hydraulic capacity rather than tipping load.
- Operator should be fully acquainted with the Operator's and Maintenance Instructions before operating this machine. Rules for safe operation of equipment should be adhered to at all times.
- Lift capacities apply to only machine as originally manufactured and normally equipped by KOBELCO CONSTRUCTION MACHINERY CO., LTD.

| SK210NLC |    | 2 Piece boom  |   | Arm: 3.50 m   |   | Bucket: without   |   | Counterweight: 4,800 kg   |   | Shoe: 600 mm (Heavy Lift)   |   |   |   |   |   |        |
|----------|----|---|---|---|---|---|---|---|---|---|---|---|---|---|---|--------|
| B        | A  | 1.5 m   |   | 3.0 m   |   | 4.5 m   |   | 6.0 m   |   | 7.5 m   |   | 9.0 m   |   | At max. reach   |   |        |
|          |    |  |  |  |  |  |  |  |  |  |  |  |  |  |  | Radius |
| 9.0 m    | kg |   |   |   |   | *5,740  | *5,740  |   |   |   |   |   |   | *4,030  | *4,030  | 5.53 m |
| 7.5 m    | kg |   |   |   |   |   |   | *4,890  | *4,890  |   |   |   |   | *3,460  | *3,460  | 7.09 m |
| 6.0 m    | kg |   |   |   |   |   |   | *5,890  | 5,420   | *4,460  | 3,650   |   |   | *3,240  | 3,140   | 8.07 m |
| 4.5 m    | kg |   |   |   |   | *6,900  | *6,900  | *6,880  | 5,170   | *4,150  | 3,550   |   |   | *3,170  | 2,690   | 8.69 m |
| 3.0 m    | kg | *27,450   | *27,450   | *15,750   | 14,140  | *10,210   | 7,450   | *7,810  | 4,810   | *4,070  | 3,380   | *3,330  | 2,460   | *3,230  | 2,450   | 9.01 m |
| 1.5 m    | kg | *18,250   | *18,250   | *17,840   | 12,340  | *11,280   | 6,690   | 7,910   | 4,450   | *4,400  | 3,190   | *3,890  | 2,390   | *3,390  | 2,350   | 9.08 m |
| G.L.     | kg | *19,130   | *19,130   | *6,700  | *6,700  | *11,360   | 6,230   | 7,590   | 4,180   | *5,180  | 3,050   |   |   | *3,710  | 2,380   | 8.89 m |
| -1.5 m   | kg |   |   | *9,990  | *9,990  | *10,390   | 6,070   | 7,440   | 4,050   | 5,350   | 2,980   |   |   | *4,220  | 2,550   | 8.43 m |
| -3.0 m   | kg |   |   | *10,660   | *10,660   | *8,420  | 6,110   | *6,380  | 4,060   | *4,300  | 3,030   |   |   | *4,000  | 2,970   | 7.65 m |
| -4.5 m   | kg |   |   | *14,570   | 12,430  | *5,130  | *5,130  | *4,490  | 4,260   |   |   |   |   | *2,700  | *2,700  | 6.43 m |

| SK210NLC |    | 2 Piece boom  |   | Arm: 2.40 m   |   | Bucket: without   |   | Counterweight: 4,800 kg   |   | Shoe: 600 mm (Heavy Lift)   |   |   |   |   |   |        |
|----------|----|---|---|---|---|---|---|---|---|---|---|---|---|---|---|--------|
| B        | A  | 1.5 m   |   | 3.0 m   |   | 4.5 m   |   | 6.0 m   |   | 7.5 m   |   | At max. reach   |   |   |   |        |
|          |    |  |  |  |  |  |  |  |  |  |  |  |  |  |  | Radius |
| 9.0 m    | kg |   |   |   |   |   |   |   |   |   |   |   |   | *7,980  | *7,980  | 3.73 m |
| 7.5 m    | kg |   |   |   |   | *8,830  | 8,540   |   |   |   |   |   |   | *6,060  | 5,440   | 5.80 m |
| 6.0 m    | kg |   |   |   |   | *9,000  | 8,340   | *5,580  | 5,190   |   |   |   |   | *5,130  | 3,950   | 6.97 m |
| 4.5 m    | kg |   |   | *14,150   | *14,150   | *10,110   | 7,770   | *4,770  | *4,770  | *5,240  | 3,440   |   |   | *4,720  | 3,290   | 7.68 m |
| 3.0 m    | kg |   |   | *15,800   | 13,530  | *11,250   | 7,020   | 8,140   | 4,670   | *5,500  | 3,330   |   |   | *4,580  | 2,970   | 8.05 m |
| 1.5 m    | kg |   |   | *17,890   | 12,210  | *11,600   | 6,450   | 7,810   | 4,380   | 5,590   | 3,210   |   |   | *4,650  | 2,860   | 8.12 m |
| G.L.     | kg | *25,320   | *25,320   | *15,660   | 11,800  | *10,800   | 6,230   | 7,610   | 4,210   | 5,510   | 3,130   |   |   | *4,930  | 2,930   | 7.91 m |
| -1.5 m   | kg |   |   | *9,810  | *9,810  | *9,050  | 6,240   | *7,020  | 4,190   |   |   |   |   | *4,810  | 3,230   | 7.39 m |
| -3.0 m   | kg |   |   |   |   | *6,250  | *6,250  | *4,580  | 4,330   |   |   |   |   | *3,540  | *3,540  | 6.48 m |

| SK210SNLC |    | 2 Piece boom  |   | Arm: 2.94 m   |   | Bucket: without   |   | Counterweight: 4,900 kg   |   | Shoe: 500 mm (Heavy Lift)   |   |   |   |   |   |        |
|-----------|----|---|---|---|---|---|---|---|---|---|---|---|---|---|---|--------|
| B         | A  | 1.5 m   |   | 3.0 m   |   | 4.5 m   |   | 6.0 m   |   | 7.5 m   |   | At max. reach   |   |   |   |        |
|           |    |  |  |  |  |  |  |  |  |  |  |  |  |  |  | Radius |
| 9.0 m     | kg |   |   |   |   | *5,330  | *5,330  |   |   |   |   |   |   | *4,460  | *4,460  | 4.74 m |
| 7.5 m     | kg |   |   |   |   | *6,130  | *6,130  | *5,100  | 4,980   |   |   |   |   | *3,650  | *3,650  | 6.49 m |
| 6.0 m     | kg |   |   |   |   | *6,210  | *6,210  | *4,130  | *4,130  | *3,700  | 3,300   |   |   | *3,340  | 3,250   | 7.55 m |
| 4.5 m     | kg |   |   | *9,450  | *9,450  | *8,300  | 7,420   | *6,810  | 4,720   | *4,310  | 3,260   |   |   | *3,230  | 2,750   | 8.21 m |
| 3.0 m     | kg | *28,190   | *28,190   | *14,620   | 12,230  | *9,640  | 6,670   | *7,250  | 4,390   | *4,270  | 3,120   |   |   | *3,250  | 2,490   | 8.55 m |
| 1.5 m     | kg |   |   | *15,880   | 10,830  | *10,260   | 6,020   | *7,530  | 4,080   | *4,590  | 2,960   |   |   | *3,400  | 2,390   | 8.62 m |
| G.L.      | kg | *18,160   | *18,160   | *13,120   | 10,470  | *9,920  | 5,690   | *7,370  | 3,860   | *5,260  | 2,850   |   |   | *3,700  | 2,430   | 8.42 m |
| -1.5 m    | kg |   |   | *9,060  | *9,060  | *8,660  | 5,620   | *6,600  | 3,790   | *4,800  | 2,830   |   |   | *4,100  | 2,650   | 7.93 m |
| -3.0 m    | kg |   |   | *7,450  | *7,450  | *6,500  | 5,730   | *4,930  | 3,850   |   |   |   |   | *3,270  | 3,150   | 7.10 m |
| -4.5 m    | kg |   |   | *10,510   | *10,510   | *5,880  | *5,880  |   |   |   |   |   |   | *1,470  | *1,470  | 5.76 m |

| SK210SNLC |    | 2 Piece boom  |   | Arm: 2.40 m   |   | Bucket: without   |   | Counterweight: 4,900 kg   |   | Shoe: 500 mm (Heavy Lift)   |   |   |   |   |   |        |
|-----------|----|---|---|---|---|---|---|---|---|---|---|---|---|---|---|--------|
| B         | A  | 1.5 m   |   | 3.0 m   |   | 4.5 m   |   | 6.0 m   |   | 7.5 m   |   | At max. reach   |   |   |   |        |
|           |    |  |  |  |  |  |  |  |  |  |  |  |  |  |  | Radius |
| 9.0 m     | kg |   |   |   |   |   |   |   |   |   |   |   |   | *7,240  | *7,240  | 3.73 m |
| 7.5 m     | kg |   |   |   |   | *7,980  | 7,940   |   |   |   |   |   |   | *5,450  | 5,060   | 5.80 m |
| 6.0 m     | kg |   |   |   |   | *8,150  | 7,750   | *5,010  | 4,840   |   |   |   |   | *4,600  | 3,680   | 6.97 m |
| 4.5 m     | kg |   |   | *12,700   | *12,700   | *9,050  | 7,190   | *4,260  | *4,260  | *4,690  | 3,200   |   |   | *4,220  | 3,050   | 7.68 m |
| 3.0 m     | kg |   |   | *14,110   | 12,250  | *10,030   | 6,460   | *7,470  | 4,320   | *4,920  | 3,090   |   |   | *4,090  | 2,750   | 8.05 m |
| 1.5 m     | kg |   |   | *15,910   | 10,990  | *10,310   | 5,910   | *7,600  | 4,040   | *5,250  | 2,960   |   |   | *4,150  | 2,640   | 8.12 m |
| G.L.      | kg | *22,430   | *22,430   | *13,860   | 10,590  | *9,550  | 5,690   | *7,240  | 3,880   | *5,430  | 2,890   |   |   | *4,400  | 2,700   | 7.91 m |
| -1.5 m    | kg |   |   | *8,560  | *8,560  | *7,970  | 5,700   | *6,190  | 3,850   |   |   |   |   | *4,210  | 2,980   | 7.39 m |
| -3.0 m    | kg |   |   |   |   | *5,430  | *5,430  | *3,980  | *3,980  |   |   |   |   | *3,050  | *3,050  | 6.48 m |

Notes:

- Do not attempt to lift or hold any load that is greater than these lift capacities at their specified lift point radius and heights. Weight of all accessories must be deducted from the above lift capacities.
- Lift capacities are based on machine standing on level, firm, and uniform ground. User must make allowance for job conditions such as soft or uneven ground, out of level conditions, side loads, sudden stopping of loads, hazardous conditions, experience of personnel, etc.
- Arm top defined as lift point.
- The above lift capacities are in compliance with ISO 10567. They do not exceed 87% of hydraulic lift capacity or 75% of tipping load. Lift capacities marked with an asterisk (\*) are limited by hydraulic capacity rather than tipping load.
- Operator should be fully acquainted with the Operator's and Maintenance Instructions before operating this machine. Rules for safe operation of equipment should be adhered to at all times.
- Lift capacities apply to only machine as originally manufactured and normally equipped by KOBELCO CONSTRUCTION MACHINERY CO., LTD.

## Long Reach Attachment Specifications

### Working ranges

Unit: mm

| Boom   | 8.75 m |
|--|--------|
| Arm  | 6.35 m |
| <b>Range</b>                                 |        |
| a- Max. digging reach                        | 15,820 |
| b- Max. digging reach at ground level        | 15,710 |
| c- Max. digging depth                        | 12,010 |
| d- Max. digging height                       | 13,900 |
| e- Max. dumping clearance                    | 11,530 |
| f- Min. dumping clearance                    | 2,080  |
| g- Max. vertical wall digging depth          | 11,190 |
| h- Min. swing radius                         | 4,730  |
| i- Horizontal digging stroke at ground level | 11,610 |
| j- Digging depth for 2.4 m (8') flat bottom  | 11,910 |
| Bucket capacity ISO heaped m <sup>3</sup>    | 0.45   |

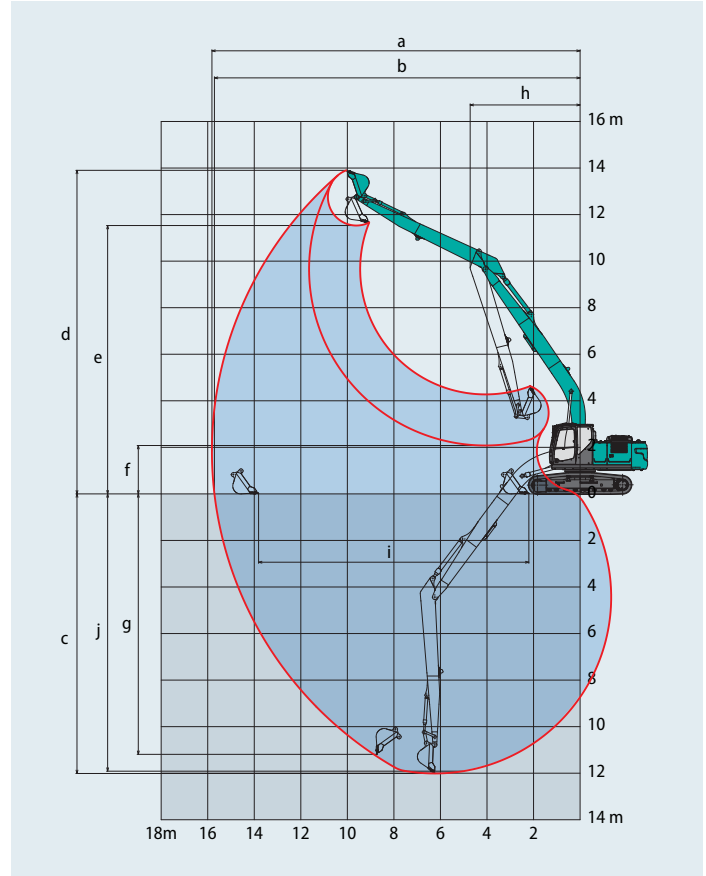

### Digging Force (ISO 6015)

Unit: kN

| Arm length           | Standard 6.35 m |
|----------------------|-----------------|
| Bucket digging force | 88              |
| Arm crowding force   | 54              |

### Dimensions (SK210LC)

| Arm length                        | Standard 6.35 m |
|-----------------------------------|-----------------|
| A Overall length                  | 12,690          |
| B Overall height (to top of boom) | 3,160           |
| C Overall width of crawler        | 2,990           |
| D Overall height (to top of cab)  | 3,060           |
| E Ground clearance of rear end*   | 1,060           |
| F Ground clearance*               | 425             |

Unit: mm

|  |       |
|--|-------|
| G Tail swing radius                          | 2,910 |
| G' Distance from centre of swing to rear end | 2,900 |
| H Tumbler distance                           | 3,660 |
| I Overall length of crawler                  | 4,450 |
| J Track gauge                                | 2,390 |
| K Shoe width                                 | 600   |
| L Overall width of upperstructure            | 2,710 |

\*Without including height of shoe

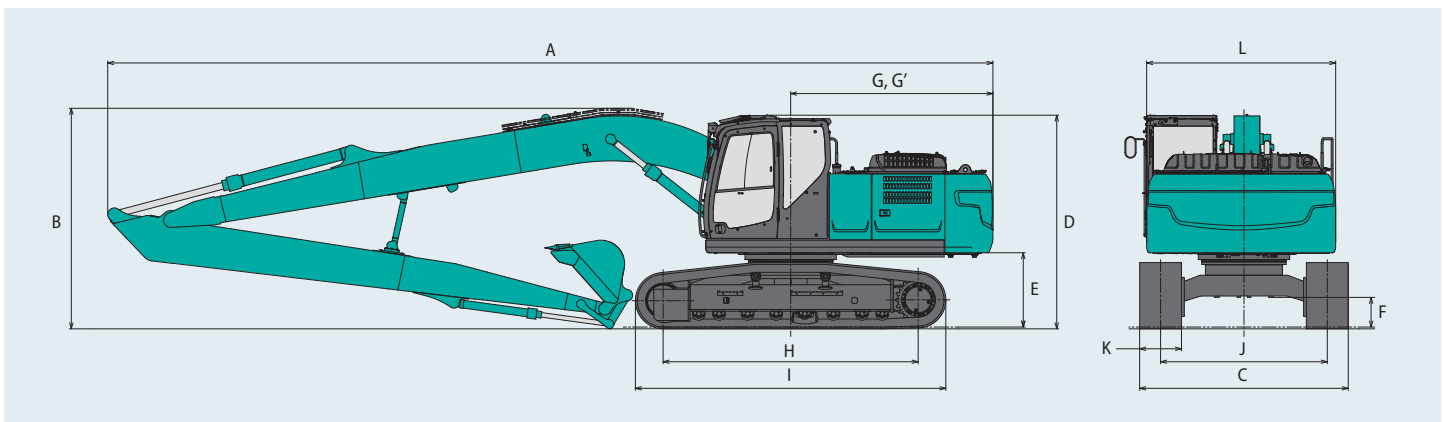

# Operating weight & ground pressure

In standard trim, with 8.75 m boom, 6.35 m arm, and 0.45 m<sup>3</sup> ISO heaped bucket.

| Shaped                   |     | Triple grouser shoes (even height) |        |        |        |
|--------------------------|-----|------------------------------------|--------|--------|--------|
| Shoe width               | mm  | 600                                | 700    | 790    | 900    |
| Overall width of crawler | mm  | 2,990                              | 3,090  | 3,180  | 3,290  |
| Ground pressure          | kPa | 49                                 | 43     | 38     | 34     |
| Operating weight         | kg  | 23,600                             | 24,100 | 24,300 | 24,600 |

## Lift capacities

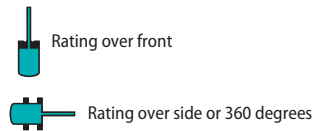
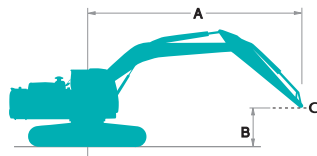

A - Reach from swing centerline to arm top  
 B - Arm top height above/below ground  
 C - Lift point  
 Relief valve setting: 34.3 MPa

| SK210LC |    | Boom: 8.75 m Arm: 6.35 m Bucket: without Counterweight: 5,490 kg Shoe: 600mm |        |        |        |        |        |        |        |        |        |        |        |        |        |        |        |        |        |               |        |        |         |         |
|---------|----|--|--------|--------|--------|--------|--------|--------|--------|--------|--------|--------|--------|--------|--------|--------|--------|--------|--------|---------------|--------|--------|---------|---------|
| B       | A  | 1.5 m  |        | 3.0 m  |        | 4.5 m  |        | 6.0 m  |        | 7.5 m  |        | 9.0 m  |        | 10.5 m |        | 12.0 m |        | 13.5 m |        | At max. reach |        | Radius |         |         |
|         |    |  |        |        |        |        |        |        |        |        |        |        |        |        |        |        |        |        |        |               |        |        |         |         |
| 12.0 m  | kg |  |        |        |        |        |        |        |        |        |        |        |        |        |        |        |        |        |        |               | *1,080 | *1,080 | 10.44 m |         |
| 10.5 m  | kg |  |        |        |        |        |        |        |        |        |        |        |        | *1,880 | *1,880 |        |        |        |        |               |        | *1,000 | *1,000  | 11.72 m |
| 9.0 m   | kg |  |        |        |        |        |        |        |        |        |        |        |        | *2,220 | *2,220 | *1,620 | *1,620 |        |        |               |        | *950   | *950    | 12.70 m |
| 7.5 m   | kg |  |        |        |        |        |        |        |        |        |        |        |        | *2,430 | *2,430 | *2,070 | *2,070 |        |        |               |        | *930   | *930    | 13.44 m |
| 6.0 m   | kg |  |        |        |        |        |        |        |        |        |        |        |        | *2,560 | *2,560 | *2,400 | 2,060  | *1,510 | *1,510 |               |        | *930   | *930    | 13.98 m |
| 4.5 m   | kg |  |        |        |        |        |        |        |        |        |        |        | *3,020 | *3,020 | *2,740 | 2,520  | *2,550 | 1,980  | *1,900 | 1,560         |        | *940   | *940    | 14.35 m |
| 3.0 m   | kg |  |        | *5,190 | *5,190 | *6,520 | *6,520 | *4,810 | *4,810 | *3,890 | *3,890 | *3,330 | 3,050  | *2,950 | 2,380  | *2,680 | 1,880  | *2,190 | 1,500  |               | *970   | *970   | 14.54 m |         |
| 1.5 m   | kg |  |        |        |        | *7,340 | 7,280  | *5,600 | 4,990  | *4,380 | 3,680  | *3,640 | 2,830  | *3,160 | 2,230  | *2,810 | 1,780  | 2,350  | 1,440  |               | *1,020 | *1,020 | 14.58 m |         |
| G.L.    | kg |  |        | *2,060 | *2,060 | *4,980 | *4,980 | *6,190 | 4,520  | *4,780 | 3,380  | *3,910 | 2,630  | *3,340 | 2,090  | 2,760  | 1,690  | 2,300  | 1,380  |               | *1,090 | *1,090 | 14.47 m |         |
| -1.5 m  | kg | *2,040   | *2,040 | *2,810 | *2,810 | *4,960 | *4,960 | *6,520 | 4,230  | *5,050 | 3,160  | 4,040  | 2,470  | 3,250  | 1,990  | 2,680  | 1,620  | 2,250  | 1,340  |               | *1,180 | *1,180 | 14.19 m |         |
| -3.0 m  | kg | *2,940   | *2,940 | *3,720 | *3,720 | *5,610 | *5,610 | *6,610 | 4,090  | 5,070  | 3,030  | 3,930  | 2,370  | 3,170  | 1,910  | 2,630  | 1,570  | *1,860 | 1,320  |               | *1,320 | 1,290  | 13.75 m |         |
| -4.5 m  | kg | *3,880   | *3,880 | *4,740 | *4,740 | *6,630 | 6,140  | *6,480 | 4,040  | 5,010  | 2,970  | 3,880  | 2,320  | 3,140  | 1,880  | 2,620  | 1,560  |        |        |               | *1,510 | 1,380  | 13.11 m |         |
| -6.0 m  | kg | *4,890   | *4,890 | *5,910 | *5,910 | *7,960 | 6,250  | *6,120 | 4,080  | *4,890 | 2,980  | 3,880  | 2,320  | 3,150  | 1,890  | *2,580 | 1,590  |        |        |               | *1,800 | 1,550  | 12.26 m |         |
| -7.5 m  | kg | *6,030   | *6,030 | *7,300 | *7,300 | *7,040 | 6,440  | *5,510 | 4,190  | *4,440 | 3,050  | *3,620 | 2,380  | *2,900 | 1,950  |        |        |        |        |               |        | *2,290 | 1,820   | 11.15 m |
| -9.0 m  | kg |  |        | *7,450 | *7,450 | *5,700 | *5,700 | *4,550 | 4,380  | *3,660 | 3,200  | *2,860 | 2,520  |        |        |        |        |        |        |               |        | *2,470 | 2,310   | 9.67 m  |
| -10.5 m | kg |  |        |        |        | *3,700 | *3,700 | *2,980 | *2,980 | *2,190 | *2,190 |        |        |        |        |        |        |        |        |               |        | *2,110 | *2,110  | 7.62 m  |

### Notes:

- Do not attempt to lift or hold any load that is greater than these lift capacities at their specified lift point radius and heights. Weight of all accessories must be deducted from the above lift capacities.
- Lift capacities are based on machine standing on level, firm, and uniform ground. User must make allowance for job conditions such as soft or uneven ground, out of level conditions, side loads, sudden stopping of loads, hazardous conditions, experience of personnel, etc.
- Arm top defined as lift point.
- The above lift capacities are in compliance with ISO 10567. They do not exceed 87% of hydraulic lift capacity or 75% of tipping load. Lift capacities marked with an asterisk (\*) are limited by hydraulic capacity rather than tipping load.
- Operator should be fully acquainted with the Operator's and Maintenance Instructions before operating this machine. Rules for safe operation of equipment should be adhered to at all times.
- Lift capacities apply to only machine as originally manufactured and normally equipped by KOBELCO CONSTRUCTION MACHINERY CO., LTD.



## Standard and Optional Equipment

● =Std ○ =Opt — =N/A

| Category  | Description  | SK210(N)LC-11E           |     |      |            |
|---|--|--------------------------|-----|------|------------|
|   |  | Mono boom / 2 Piece boom |     |      | Long Reach |
|   |  | LC                       | NLC | SNLC | LC         |
| ENGINE  | YANMAR 4TN107FTT (EU Stage V compliant)                                | ●                        | ●   | ●    | ●          |
|   | Exhaust DOC DPF SCR system   | ●                        | ●   | ●    | ●          |
|   | Alternator 24 V/80 A   | ●                        | ●   | ●    | ●          |
|   | Starter motor 24 V/5 kW  | ●                        | ●   | ●    | ●          |
|   | Batteries 2 x 12 V (130 Ah)  | ●                        | ●   | ●    | ●          |
|   | Fan suction type cooling system  | ●                        | ●   | ●    | ●          |
|   | Auto deceleration function   | ●                        | ●   | ●    | ●          |
|   | Auto Idle Stop (AIS)   | ●                        | ●   | ●    | ●          |
| HYDRAULIC SYSTEM                                      | 3 work modes H, S, Eco   | ●                        | ●   | ●    | ●          |
|   | Power boost (37.8 MPa)   | ●                        | ●   | ●    | —          |
|   | Heavy lift mode  | ●                        | ●   | ●    | —          |
|   | Pressure release function  | ●                        | ●   | ●    | ●          |
|   | Independent travel function  | ●                        | ●   | ●    | ●          |
|   | Auto warm up system  | ●                        | ●   | ●    | ●          |
|   | Proportional Hand Control (for E&N&B piping)                           | —                        | —   | —    | —          |
|   | Proportional Hand Control (for Extra piping)                           | —                        | —   | —    | ●          |
|   | Hydraulic oil VG32   | ●                        | ●   | ●    | ●          |
|   | Hydraulic oil VG46   | ○                        | ○   | ○    | ○          |
|   | Hydraulic oil VG68   | ○                        | ○   | ○    | ○          |
|   | PIPING   | E & N&B piping           | ●   | ●    | ●          |
| E & N&B piping + Bigger capacity P4 pump (89.4 L/min) |  | —                        | ○   | —    | —          |
| Standard piping (only mono boom spec)                 |  | ○                        | —   | —    | —          |
| Extra piping  |  | —                        | —   | —    | ●          |
| CABIN   | QH piping  | ●                        | ●   | ●    | ●          |
|   | Air suspension seat with heating                                       | ●                        | ●   | ●    | ●          |
|   | 10 inch colour monitor   | ●                        | ●   | ●    | ●          |
|   | LED door light   | ●                        | ●   | ●    | ●          |
|   | Air-conditioner  | ●                        | ●   | ●    | ●          |
|   | DAB+ radio (FM/AM & AUX & USB & Bluetooth* & hands free telephone)     | ●                        | ●   | ●    | ●          |
|   | Harness for CAB four lights and CAB yellow flasher                     | ●                        | ●   | ●    | ●          |
|   | Parallel wiper   | ●                        | ●   | ●    | ●          |
|   | 12 V power outlet  | ●                        | ●   | ●    | ●          |
|   | Rain visor   | ○                        | ○   | ○    | ○          |
|   | Sun screen   | ●                        | ●   | ●    | ●          |
| LIGHTS  | Large footrest   | ●                        | ●   | ●    | ●          |
|   | LED work lights ; 2 on boom, 1 on upper frame, 2 on rear counterweight | ●                        | ●   | ●    | ●          |
| WORKING EQUIPMENT                                     | LED work lights ; 2 on CAB top front                                   | ○                        | ○   | ○    | ○          |
|   | Standard Boom (5.65 m)   | ●                        | ●   | ●    | —          |
|   | 2 Piece Boom   | ○                        | ○   | ○    | —          |
|   | Long Reach (50 ft)   | —                        | —   | —    | ●          |
|   | Standard HD arm (2.94 m) with rock guard                               | ●                        | ●   | ○    | —          |
|   | Short HD arm (2.40 m) with rock guard                                  | ○                        | ○   | ●    | —          |
|   | Long HD arm (3.50 m) with rock guard                                   | ○                        | ○   | —    | —          |
|   | Long Reach arm (6.35 m)  | —                        | —   | —    | ●          |
| COUNTERWEIGHT   | Bucket link with lifting hook  | ●                        | ●   | ●    | ●          |
|   | Standard C/W (TTL 4,300 kg)  | ●                        | ●   | —    | —          |
|   | Standard C/W (TTL 4,900 kg)  | —                        | —   | ●    | —          |
|   | Semi heavier C/W (TTL 4,800 kg)  | ○                        | ○   | —    | —          |
|   | Heavier C/W (TTL 5,490 kg)   | —                        | —   | —    | ●          |
| UNDERCARRIAGE   | 500 mm steel shoe  | —                        | —   | ●    | —          |
|   | 600 mm steel shoe  | ●                        | ●   | ○    | ●          |
|   | 700 mm steel shoe  | ○                        | ○   | —    | ○          |
|   | 790 mm steel shoe  | ○                        | ○   | —    | ○          |
|   | 900 mm steel shoe  | ○                        | —   | —    | ○          |
|   | Track guide (one per side)   | ●                        | ●   | ●    | ●          |
|   | Additional track guides (two additional per side)                      | ○                        | ○   | ○    | ○          |
| SAFETY  | Lower frame guard  | ●                        | ●   | ●    | ●          |
|   | Engine emergency stop switch   | ●                        | ●   | ●    | ●          |
|   | Pump emergency mode (KPSS release switch)                              | ●                        | ●   | ●    | ●          |
|   | Emergency accel dial   | ●                        | ●   | ●    | ●          |
|   | Emergency manual valve for lowering attachment                         | ●                        | ●   | ●    | ●          |
|   | Overload alarm   | ●                        | ●   | ●    | ●          |
|   | Safety valve for boom & arm cylinder                                   | ●                        | ●   | ●    | ●          |
|   | ROPS compliant cab (ISO 12117-2:2008)                                  | ●                        | ●   | ●    | ●          |
|   | OPG Level II top guard (ISO 10262:1998)                                | ●                        | ●   | ●    | ●          |
|   | OPG Level II front guard (ISO 10262:1998)                              | ○                        | ○   | ○    | ○          |
|   | Eagle-eye view camera (Rear, Right, Left)                              | ●                        | ●   | ●    | ●          |
|   | Seatbelt indicator on display  | ●                        | ●   | ●    | ●          |
|   | Travel alarm   | ○                        | ○   | —    | ○          |
|   | Extended guard rail  | ○                        | ○   | ○    | ○          |
|   | Emergency escape hammer  | ●                        | ●   | ●    | ●          |
| OTHERS  | Refueling pump   | ●                        | ●   | ●    | ●          |
|   | Harness for engine room light  | ●                        | ●   | ●    | ●          |
|   | RAL color  | ○                        | ○   | ○    | ○          |
|   | KOMEXS   | ●                        | ●   | ●    | ●          |

\*The air conditioning system on this machine contains fluorinated greenhouse gas HFC-134a (GWP 1430). Quantity of gas 0.8 kg (CO<sub>2</sub> equivalent 1.3 t).  
Note: Bluetooth\* is a registered trademark of the Bluetooth SIG Inc.

Note: This catalogue may contain attachments and optional equipment that are not available in your area. And it may contain photographs of machines with specifications that differ from those of machines sold in your areas. Please consult your nearest KOBELCO distributor for those items you require.

Specialist equipment is needed to use this machine in demolition work. Before using it please contact your KOBELCO dealer.

Due to our policy of continuous product improvements all designs and specifications are subject to change without advance notice.

Copyright by **KOBELCO CONSTRUCTION MACHINERY CO., LTD.** No part of this catalogue may be reproduced in any manner without notice.

### KOBELCO CONSTRUCTION MACHINERY EUROPE B.V.

Veluwezoom 15  
1327 AE Almere  
The Netherlands  
www.kobelco-europe.com

Enquiries To: