

KOBELCO

SK260LC/SK260NLC-11E

Performance  Design

SK260_{LC} SK260_{NLC}

- Bucket capacity:
0.40 – 1.40 m³
- Engine power:
155 kW / 2,200 min⁻¹
- Operating weight:
26,600 – 28,900 kg



Complies with the EU Stage V
exhaust emission regulation

Built for Perfectionists



Performance Design

SK260LC/SK260NLC of KOBELCO has realised a completely new value by harmonising PERFORMANCE and DESIGN.

Performance enhancements offer greater efficiency and productivity along with increased power and speed.

Design improvements provide the ultimate in comfort and control.

KOBELCO refuses to compromise, creating machines that meet every challenge.



SK260LC

THE ULTIMATE IN SIMPLE DESIGN

In our pursuit of functional beauty and styling, we created an all new interior design focused with the operator in mind.

Jog Dial

This dial integrates multiple functions into a single, easy to use interface. Even with gloves on, the operator can make the adjustments they need.

LED Illumination

Dials and buttons are now backlit to provide a bright, clear view in any lighting condition.







UNFORGETTABLE COMFORT

Air suspension seat

A GRAMMER* seat is installed as standard equipment, which achieves excellent shock absorption and superior ride comfort.

*GRAMMER is trademark of GRAMMER AG, registered in Germany and other countries.

Multi Vent Air Conditioner

Cool air is blown from multiple outlets toward the operator's body for more comfortable operation.

Ergonomic Lever Angles

Operators can move levers horizontally without twisting their wrists, reducing fatigue.



New Hydraulic Control

Our newly upgraded hydraulic control system responds to shorter lever strokes than previous models, delivering swifter, more precise movement and improved lever operability.

LED Interior Light

Interior lights turn on and off automatically when the door is open or the ignition is turned to the OFF position. This ensures safe entry and exit in the dark.

Parallel wiper secure a wide field of view



KOBELCO



04:33



SETTING MENU



PICTURE OF CAMERA



CLOCK SETTING



SCREEN BRIGHTNESS



MAINTENANCE



CONSUMPTION



LANGUAGE SELECTION



PRESSURE RELEASE



SAFETY ON FULL DISPLAY

Standard 3 Sides Safety Camera System

Our high-resolution, large display shows right, left and rear side cameras together. Multiple display allows the operator to customize viewing needs to enhance operator awareness and jobsite safety.

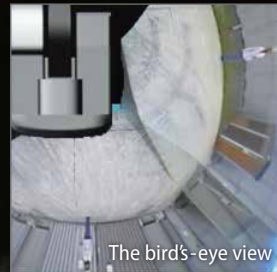
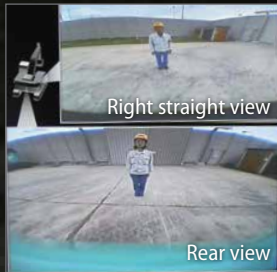

Large 10-Inch Color Monitor

The easy-to-operate menu screen and recognizable icons assist the operator to select the most important information needed to ensure jobsite safety and machine control.



Dial in the Right Information

Simply turn the jog dial to the right or left to select an operational feature, then press the dial to confirm selection.





Independent Travel

Selecting Independent Travel dedicates one hydraulic pump to travel and one to the attachment on a continuous basis, allowing for a smooth and constant movement speed even while swinging or using the boom or attachment. With Independent Travel, safely carrying a large pipe across a job site is a breeze.

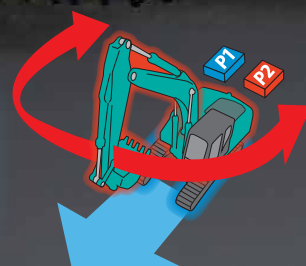

EXPERIENCING A COMPETENT PERFORMANCE

Higher Efficiency, plus a EU Stage V Compliant Engine

The new SK260LC/SK260NLC is equipped with a Yanmar Stage V compliant engine, which has a higher torque value. Superior balance between engine output and torque contributes to more efficient performance than the previous models. In addition, the DPF replacement interval has been extended.

Model: YANMAR 4TN107FTT

Engine output

155kW / 2,200 min⁻¹



>>> Max. bucket digging force (Arm 2.98 m)

Normal: **170** kN

With Power Boost: **187** kN

Lift capacity

13,390 kg

(Reach: 4.50 m Boom: 6.02 m Arm: 2.98 m Bucket: Without
Shoe: 600 mm <Heavy Lift> At Ground Level)



GREATER MULTI-FUNCTION CAPABILITIES

Attachment mode selection

The auxiliary flow rates for the bucket, breaker, nibbler, and rotating are all now adjustable by the operator through the monitor, allowing you to change tools quickly and easily. Mode settings for other attachments like the tilt rotator can be added or changed.

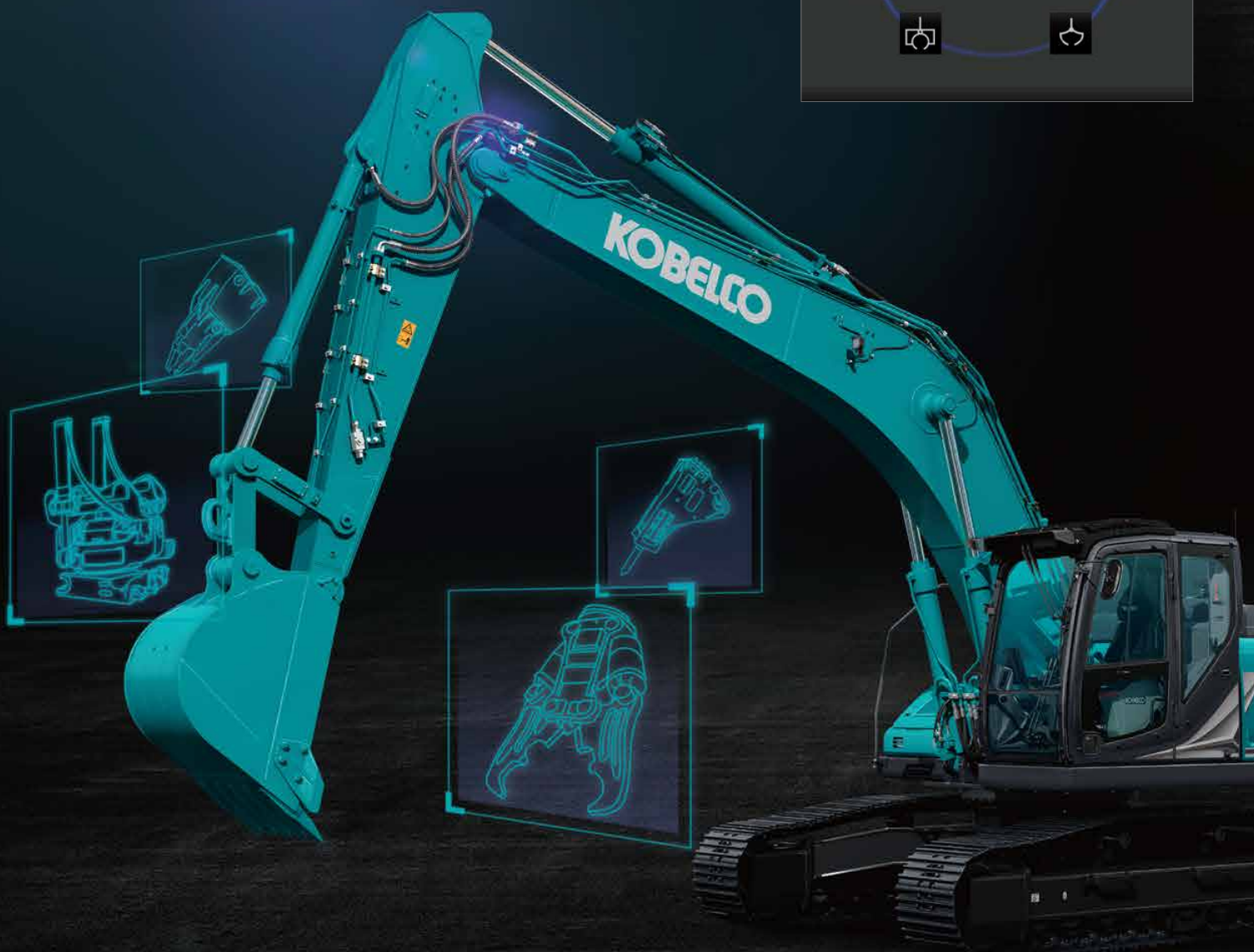

EASY MAINTENANCE



Standard Overhead Top Guard Level II

The standard overhead cab guard can be tilted open with gas damper for easy window cleaning. Meets standard top guard level II requirements (ISO 10262).



Two-stage air filter



DEF/AdBlue® Tank

The DEF/AdBlue® fill is located inside the locking tool box.



Left side (radiator and cooling system elements)

Laid out for easy access to radiator and cooling system.

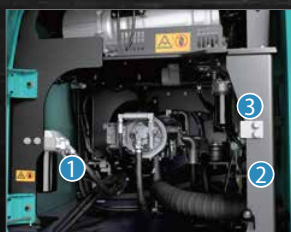

Right Side (Ground Level Maintenance)

Hydraulic pump and engine filter compartment.



Engine Oil Filter

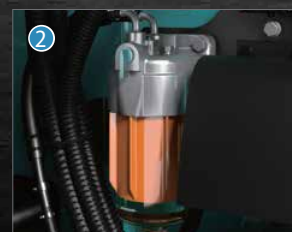

Pre-Filter with Integrated Water Separator



Fuel Filter

Note: AdBlue® is a registered trademark of the Verband der Automobilindustrie e.V. (VDA).

DURABILITY YOU CAN TRUST

Enhanced body rigidity for 25-ton class machines

The SK260LC/SK260NLC machines are widely used in mid-scale construction projects and harsh worksites. The components have been reviewed and improvements have been made to their durability to ensure stable performance in such environments.



Panels and supports

The right and left side panels and rear supports have been thicker to enhance body rigidity.



Bucket cylinder rod pin

The increased diameter of the bucket cylinder rod pin contributes to enhanced durability for various types of attachments.

CONVENIENT AND SENSIBLE EQUIPMENT



Engine start password

A password is required when starting the engine for greater security.



Wiper adjustment function

In addition to the intermittent wiper mode and continuous wiper mode, the one-time wiper mode was added.



Parallel wiper Sun screen



Console mount

The console-integrated seat allows for comfortable operation.



DAB+ radio (FM/AM & AUX & USB & Bluetooth® & hands-free telephone)



USB port/12 V power outlet



Smartphone holder

You can use the holder with your smartphone connected to the USB port.



KOBELCO MONITORING EXCAVATOR SYSTEM



Remote Monitoring for Peace of Mind

KOMEXS (Kobelco Monitoring Excavator System) uses satellite communication and internet to relay data, and therefore can be deployed in areas where other forms of communication are difficult. When a hydraulic excavator is fitted with this system, data on the machine's operation, such as operating hours, location, fuel consumption, and maintenance status can be obtained remotely.

Direct Access to Operational Status

Location Data

Accurate location data can be obtained even from sites where communications are difficult.

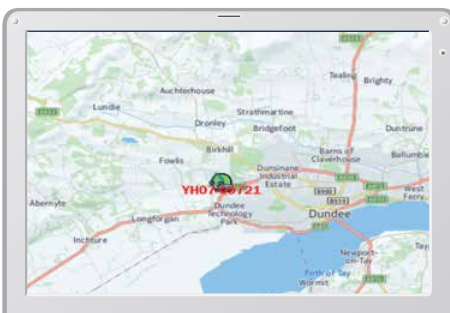

Latest location

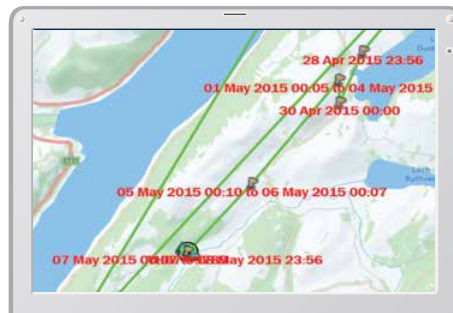

Location records

Period: 11 Apr, 2015 to 10 May, 2015		Search	
Type of Operation	Working Hrs		Ratio
Total Working Hrs	169 Hrs	100%	
Digging Hrs	72.2 Hrs	43%	
Traveling Hrs	18.3 Hrs	11%	
Idle Hrs	15.9 Hrs	9%	
Opt Att Hrs	62.5 Hrs	37%	
Crane Mode Hrs	0 Hrs	0%	

Work data

Operating Hours

- A comparison of operating times of machines at multiple locations shows which locations are busier and more profitable.
- Operating hours on site can be accurately recorded, for running time calculations needed for rental machines, etc.

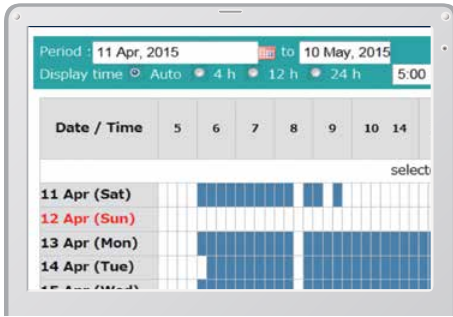

Daily report

Fuel Consumption Data

Data on fuel consumption and idling times can be used to indicate improvements in fuel consumption.

Work mode	Working Hrs	Total Fuel Consumption
H mode	2:06	24.5 L
S mode	0:00	0.0 L
E mode	169:19	1489.7 L
TOTAL	171:25	1514.2 L

Fuel consumption

Graph of Work Content

The graph shows how working hours are divided among different operating categories, including digging, idling, travelling and optional operations.

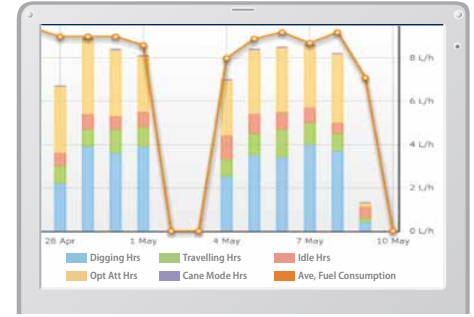

Work status

Maintenance Data and Warning Alerts

Machine Maintenance Data

- Provides maintenance status of separate machines operating at multiple sites.
- Maintenance data is also relayed to KOBELCO service personnel, for more efficient planning of periodic servicing.

Model	Serial No.	Hour Meter	Engine Oil
SK135SRLC-3/SK140SRL	YH07-09721	734 Hr	434
SK135SRLC-3/SK140SRL	YH07-09789	73 Hr	429
SK210LC-9	YQ13-10454	960 Hr	58
SK210LC-9	YQ13-10481	549 Hr	498
SK75SR-	YT08-30374		

Maintenance

Warning Alerts

This system warns an alert if an anomaly is sensed, preventing damage that could result in machine downtime.

Alarm Information Can Be Received through E-mail

Alarm information or maintenance notice can be received through E-mail, using a computer or cell phone.



Alarm messages can be received on mobile device.

Daily/Monthly Reports

Operational data downloaded onto a computer helps in formulating daily and monthly reports.

Security System

Engine Start Alarm

The system can be set an alarm if the machine is operated outside designated time.

Setting Condition
 Setting Condition Change
 Start time 20 : 00
 Release time 07 : 00
 No Working Whole Day
 Mon Tue Wed Thu Fri Sat Sun
 Clear

Engine start alarm outside prescribed work time

Area Alarm

It can be set an alarm if the machine is moved out of its designated area to another location.

Setting Condition
 Around the current (latest) location 1 Km
 Input Latitude and Longitude
 Latitude1
 Longitude1
 Latitude2
 Longitude2
 Map Clear
 Release

Alarm for outside of reset area

Specifications



Engine

Model	YANMAR 4TN107FTT
Type	Four-cycle, water-cooled, direct injection diesel engine, turbo charged, EU Stage V exhaust emission regulation
No. of cylinders	4
Bore and stroke	107 mm x 127 mm
Displacement	4.567 L
Rated power output	148 kW/2,200 min ⁻¹ (ISO 9249 : with fan)
	155 kW/2,200 min ⁻¹ (ISO 14396: without fan)
Max. torque	792 N-m/1,500 min ⁻¹ (ISO 9249: with fan)
	805 N-m/1,500 min ⁻¹ (ISO 14396: without fan)



Hydraulic System

Pump	
Type	Two variable displacement axial piston pumps + extra gear pump + pilot gear pump
Max. discharge flow	2 x 245 L/min, 1 x 42.6 L/min, 1 x 21 L/min
Relief valve setting	
Boom, arm and bucket	34.3 MPa
Power Boost*	37.8 MPa
Travel circuit	34.3 MPa
Swing circuit	28.4 MPa
Control circuit	5.0 MPa
Pilot control pump	Gear type
Main control valve	8-spool
Oil cooler	Air cooled type

*Not available for Long Reach



Swing System

Swing motor	One fixed displacement piston motor
Brake	Hydraulic; locking automatically when the swing control lever is in the neutral position
Parking brake	Wet multiple plate
Swing speed (Long Reach)	11.4 (9.2) min ⁻¹
Swing torque	85.9 kN-m
Maximum swing gradient (Loaded)*	26 % {15°}

*Value for the least favourable specification



Attachments

Backhoe bucket and combination

Use	Backhoe bucket						
	Normal digging				Light-duty		
Bucket capacity	ISO heaped	m ³	0.40	0.80	1.00	1.20	1.40
Opening width	With side cutter	mm	854	1,060	1,270	1,440	—
	Without side cutter	mm	754	960	1,180	1,340	1,510
No. of teeth			4	4	5	5	6
Bucket weight		kg	344	700	807	850	890
Combination	2.50 m short arm		—	○	○	◎	△
	2.98 m standard arm		—	○	◎	△	△
	3.66 m long arm		—	◎	△	△	×
	8.25 m arm (Long Reach)		◎	—	—	—	—

◎ Standard ○ Recommended △ Loading only × Not recommended



Travel System

Travel motors	2 x axial-piston, two-step motors
Travel brakes	Hydraulic brake per motor
Parking brakes	Oil disc brake per motor
Travel shoes	51 each side
Travel speed (Long Reach)	5.8/3.6 km/h (5.3/3.3 km/h)
Rated drawbar pull	243 kN (SAE J 1309)
Gradeability	70 % {35°}



Cab & Control

Cab

All-weather, sound-suppressed steel cab mounted on the high suspension mounts filled with silicone oil and equipped with a heavy, insulated floor mat.

Control

Two hand levers and two foot pedals for travel

Two hand levers for excavating and swing

Electric rotary-type engine throttle

Noise levels

External 104 dB(A) (2000/14/EC)

Operator 76 dB(A) (ISO 6396)

Vibration levels

Hand/arm* ≤ 2.5 m/s²

Body* ≤ 0.5 m/s²

*For the risk assessment according to 2002/44/EC, refer to ISO/TR 25398: 2006



Cylinders

Boom cylinders	135 mm x 1,235 mm
Arm cylinder	145 mm x 1,635 mm
Bucket cylinder (Long Reach)	125 mm x 1,200 mm (95 mm x 885 mm)
Jib cylinder*	150 mm x 990 mm

*For 2 Piece Boom only



Refilling Capacities & Lubrications

Fuel tank	403 L
Cooling system	23 L
Engine oil	20 L
Travel reduction gear	2 x 4.5 L
Swing reduction gear	1 x 5.0 L
Hydraulic oil tank	165 L tank oil level
	273 L hydraulic system
DEF/Urea tank	83 L



Working Ranges

Unit: mm

Range	Arm	6.02 m		
		Short 2.50 m	Standard 2.98 m	Long 3.66 m
a- Max. digging reach		9,890	10,300	10,970
b- Max. digging reach at ground level		9,720	10,140	10,820
c- Max. digging depth		6,520	7,000	7,680
d- Max. digging height		9,650	9,790	10,220
e- Max. dumping clearance		6,720	6,880	7,280
f- Min. dumping clearance		3,030	2,550	1,870
g- Max. vertical wall digging depth		5,820	6,150	6,970
h- Min. swing radius		3,910	3,910	3,920
i- Horizontal digging stroke at ground level		4,200	5,260	6,480
j- Digging depth for 2.4 m (8') flat bottom		6,320	6,820	7,540
Bucket capacity ISO heaped m ³		1.20	1.00	0.80

Digging Force (ISO 6015)

Unit: kN

Arm length	Short 2.50 m	Standard 2.98 m	Long 3.66 m
Bucket digging force	170 187*	170 187*	170 187*
Arm crowding force	142 156*	122 134*	104 114*

*Power Boost engaged

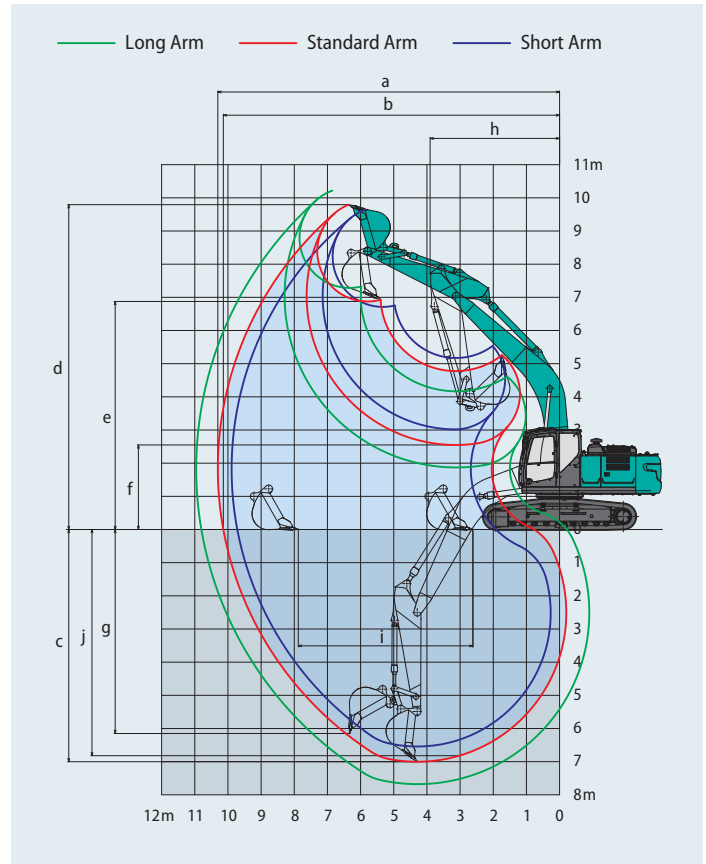

Dimensions

Arm length		Short 2.50 m	Standard 2.98 m	Long 3.66 m
A Overall length		10,270	10,210	10,220
B Overall height (to top of boom)		3,390	3,240	3,370
C Overall width of crawler	SK260LC	3,190		
	SK260NLC	2,990		
D Overall height (to top of cab)		3,090		
E Ground clearance of rear end*		1,090		
F Ground clearance*		440		

Unit: mm

G Tail swing radius		3,100
G' Distance from centre of swing to rear end		3,070
H Tumbler distance		3,850
I Overall length of crawler		4,640
J Track gauge	SK260LC	2,590
	SK260NLC	2,390
K Shoe width		600
L Overall width of upperstructure		2,980

*Without including height of shoe lug

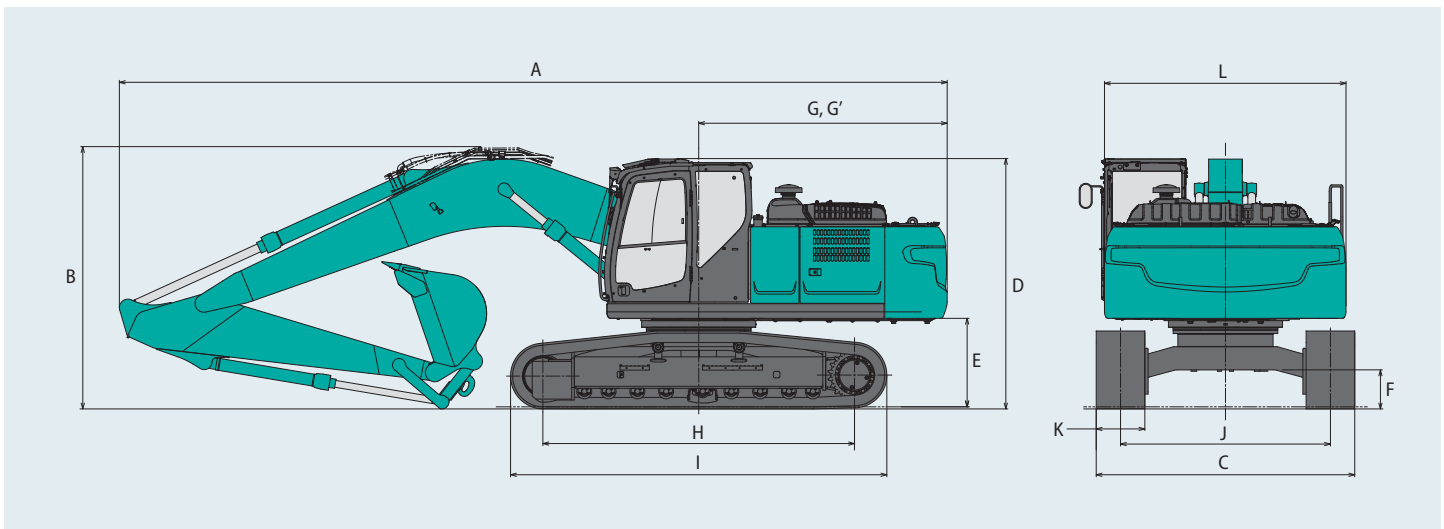

Operating Weight & Ground Pressure

In standard trim, with Standard Boom, 2.98 m arm, and 1.00 m³ ISO heaped bucket.

Shaped			Triple grouser shoes (even height)			
Shoe width	mm		600	700	800	900
Overall width of crawler	SK260LC	mm	3,190	3,290	3,390	3,490
	SK260NLC	mm	2,990	3,090	3,190	—
Ground pressure	SK260LC	kPa	53	46	41	37
	SK260NLC	kPa	53	46	40	—
Operating weight	SK260LC	kg	26,700	27,000	27,300	27,700
	SK260NLC	kg	26,600	27,000	27,200	—

Lift Capacities

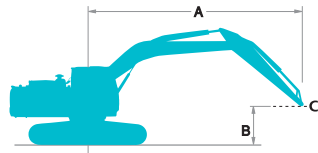

Rating over front



Rating over side or 360 degrees

A: Reach from swing centreline to arm top

B: Arm top height above/below ground

C: Lift point

Bucket: Without bucket

Relief valve setting: 37.8 MPa

SK260LC		Boom: 6.02 m		Arm: 2.98 m		Bucket: without		Counterweight: 5,580 kg		Shoe: 600 mm (Heavy Lift)						
B	A	1.5 m		3.0 m		4.5 m		6.0 m		7.5 m		At max. reach		Radius		
7.5 m	kg												*4,930	*4,930	6.70 m	
6.0 m	kg								*5,800	*5,800	*5,850	5,100	*4,660	*4,660	7.73 m	
4.5 m	kg								*6,590	*6,590	*6,110	5,000	*4,620	4,150	8.37 m	
3.0 m	kg							*10,070	*10,070	*7,720	6,710	*6,660	4,810	*4,750	3,800	8.71 m
1.5 m	kg							*12,240	9,500	*8,870	6,340	7,010	4,620	*5,060	3,660	8.78 m
G.L.	kg							*13,390	9,120	9,540	6,080	6,850	4,480	*5,620	3,720	8.58 m
-1.5 m	kg	*7,380	*7,380	*11,560	*11,560	*13,590	9,030	9,410	5,970	6,790	4,420	6,090	4,000			8.11 m
-3.0 m	kg	*13,010	*13,010	*18,450	18,270	*12,960	9,120	9,460	6,010				7,130	4,650		7.30 m
-4.5 m	kg			*15,600	*15,600	*11,200	9,400	*8,040	6,260				*8,010	6,240		6.01 m

SK260LC		Boom: 6.02 m		Arm: 3.66 m		Bucket: without		Counterweight: 5,580 kg		Shoe: 600 mm (Heavy Lift)						
B	A	1.5 m		3.0 m		4.5 m		6.0 m		7.5 m		9.0 m		At max. reach		Radius
7.5 m	kg									*3,870	*3,870			*3,610	*3,610	7.56 m
6.0 m	kg									*5,080	*5,080			*3,420	*3,420	8.49 m
4.5 m	kg							*5,760	*5,760	*5,450	5,050			*3,380	*3,380	9.08 m
3.0 m	kg			*13,780	*13,780	*8,770	*8,770	*6,950	6,810	*6,080	4,830	*5,250	3,600	*3,450	3,340	9.39 m
1.5 m	kg					*11,190	9,680	*8,210	6,380	*6,780	4,600	5,290	3,490	*3,630	3,230	9.45 m
G.L.	kg			*7,060	*7,060	*12,790	9,130	*9,230	6,050	6,800	4,420	5,200	3,400	*3,960	3,260	9.27 m
-1.5 m	kg	*6,500	*6,500	*10,570	*10,570	*13,440	8,910	9,320	5,880	6,680	4,310			*4,520	3,460	8.83 m
-3.0 m	kg	*10,600	*10,600	*15,510	*15,510	*13,240	8,910	9,290	5,850	6,680	4,310			*5,530	3,920	8.10 m
-4.5 m	kg	*15,650	*15,650	*17,320	*17,320	*12,080	9,100	*8,940	5,980					*7,250	4,920	6.96 m
-6.0 m	kg					*9,100	*9,100							*7,540	*7,540	5.17 m

SK260LC		Boom: 6.02 m Arm: 2.50 m Bucket: without Counterweight: 5,580 kg Shoe: 600 mm (Heavy Lift)										
A \ B		3.0 m		4.5 m		6.0 m		7.5 m		At max. reach		Radius
7.5 m	kg					*6,360	*6,360			*6,440	*6,440	6.14 m
6.0 m	kg					*6,330	*6,330			*6,400	5,260	7.26 m
4.5 m	kg			*8,450	*8,450	*7,060	6,970	*6,510	4,910	*6,400	4,450	7.94 m
3.0 m	kg			*10,850	9,970	*8,140	6,580	*6,960	4,740	6,090	4,050	8.29 m
1.5 m	kg			*12,780	9,290	*9,180	6,240	6,950	4,570	5,910	3,910	8.36 m
G.L.	kg			*13,550	9,030	9,470	6,020	6,820	4,450	6,060	3,980	8.16 m
-1.5 m	kg	*11,410	*11,410	*13,430	9,020	9,400	5,960	6,810	4,440	6,620	4,330	7.66 m
-3.0 m	kg	*17,240	*17,240	*12,500	9,170	*9,380	6,060			7,960	5,170	6.79 m
-4.5 m	kg	*13,930	*13,930	*10,190	9,550					*8,190	7,400	5.38 m

SK260NLC		Boom: 6.02 m Arm: 2.98 m Bucket: without Counterweight: 5,580 kg Shoe: 600 mm (Heavy Lift)												
A \ B		1.5 m		3.0 m		4.5 m		6.0 m		7.5 m		At max. reach		Radius
7.5 m	kg											*4,930	*4,930	6.70 m
6.0 m	kg							*5,800	*5,800	*5,850	4,700	*4,660	4,440	7.73 m
4.5 m	kg							*6,590	6,540	*6,110	4,600	*4,620	3,810	8.37 m
3.0 m	kg					*10,070	9,330	*7,720	6,150	*6,660	4,420	*4,750	3,480	8.71 m
1.5 m	kg					*12,240	8,590	*8,870	5,780	6,990	4,230	*5,060	3,350	8.78 m
G.L.	kg					*13,390	8,230	9,510	5,530	6,830	4,090	*5,620	3,400	8.58 m
-1.5 m	kg	*7,380	*7,380	*11,560	*11,560	*13,590	8,130	9,390	5,430	6,770	4,030	6,070	3,650	8.11 m
-3.0 m	kg	*13,010	*13,010	*18,450	16,070	*12,960	8,220	9,430	5,460			7,110	4,250	7.30 m
-4.5 m	kg			*15,600	*15,600	*11,200	8,500	*8,040	5,710			*8,010	5,690	6.01 m

SK260NLC		Boom: 6.02 m Arm: 3.66 m Bucket: without Counterweight: 5,580 kg Shoe: 600 mm (Heavy Lift)														
A \ B		1.5 m		3.0 m		4.5 m		6.0 m		7.5 m		9.0 m		At max. reach		Radius
7.5 m	kg									*3,870	*3,870			*3,610	*3,610	7.56 m
6.0 m	kg									*5,080	4,790			*3,420	*3,420	8.49 m
4.5 m	kg							*5,760	*5,760	*5,450	4,650	*3,790	3,380	*3,380	3,320	9.08 m
3.0 m	kg			*13,780	*13,780	*8,770	*8,770	*6,950	6,240	*6,080	4,430	*5,250	3,290	*3,450	3,060	9.39 m
1.5 m	kg					*11,190	8,760	*8,210	5,820	*6,780	4,210	5,280	3,190	*3,630	2,940	9.45 m
G.L.	kg			*7,060	*7,060	*12,790	8,230	*9,230	5,500	6,780	4,030	5,180	3,100	*3,960	2,970	9.27 m
-1.5 m	kg	*6,500	*6,500	*10,570	*10,570	*13,440	8,020	9,300	5,330	6,660	3,920			*4,520	3,150	8.83 m
-3.0 m	kg	*10,600	*10,600	*15,510	*15,510	*13,240	8,020	9,260	5,300	6,660	3,930			*5,530	3,570	8.10 m
-4.5 m	kg	*15,650	*15,650	*17,320	16,060	*12,080	8,200	*8,940	5,430					*7,250	4,490	6.96 m
-6.0 m	kg					*9,100	8,660							*7,540	7,120	5.17 m

SK260NLC		Boom: 6.02 m Arm: 2.50 m Bucket: without Counterweight: 5,580 kg Shoe: 600 mm (Heavy Lift)										
A \ B		3.0 m		4.5 m		6.0 m		7.5 m		At max. reach		Radius
7.5 m	kg					*6,360	*6,360			*6,440	*6,440	6.14 m
6.0 m	kg					*6,330	*6,330			*6,400	4,840	7.26 m
4.5 m	kg			*8,450	*8,450	*7,060	6,410	*6,510	4,510	*6,400	4,090	7.94 m
3.0 m	kg			*10,850	9,050	*8,140	6,030	*6,960	4,350	6,080	3,710	8.29 m
1.5 m	kg			*12,780	8,390	*9,180	5,690	6,930	4,180	5,890	3,570	8.36 m
G.L.	kg			*13,550	8,140	9,450	5,480	6,800	4,060	6,040	3,640	8.16 m
-1.5 m	kg	*11,410	*11,410	*13,430	8,120	9,380	5,420	6,790	4,050	6,600	3,950	7.66 m
-3.0 m	kg	*17,240	16,240	*12,500	8,270	*9,380	5,510			7,940	4,720	6.79 m
-4.5 m	kg	*13,930	*13,930	*10,190	8,640					*8,190	6,740	5.38 m

Notes:

- Do not attempt to lift or hold any load that is greater than these lift capacities at their specified lift point radius and heights. Weight of all accessories must be deducted from the above lift capacities.
- Lift capacities are based on machine standing on level, firm, and uniform ground. User must make allowance for job conditions such as soft or uneven ground, out of level conditions, side loads, sudden stopping of loads, hazardous conditions, experience of personnel, etc.
- Arm top defined as lift point.
- The above lift capacities are in compliance with ISO 10567. They do not exceed 87% of hydraulic lift

capacity or 75% of tipping load. Lift capacities marked with an asterisk(*) are limited by hydraulic capacity rather than tipping load.

- Operator should be fully acquainted with the Operator's and Maintenance Instructions before operating this machine. Rules for safe operation of equipment should be adhered to at all times.
- Lift capacities apply to only machine as originally manufactured and normally equipped by KOBELCO CONSTRUCTION MACHINERY CO., LTD.

2 Piece Boom Specifications



Working Ranges

Unit: mm

Boom	Arm	2 Piece Boom
		Standard 2.98 m
a- Max. digging reach		10,670
b- Max. digging reach at ground level		10,510
c- Max. digging depth		6,820
d- Max. digging height		11,670
e- Max. dumping clearance		8,650
f- Min. dumping clearance		3,580
g- Max. vertical wall digging depth		4,920
h- Min. swing radius		2,630
i- Horizontal digging stroke at ground level		8,050
j- Digging depth for 2.4 m (8') flat bottom		6,770
Bucket capacity ISO heaped m ³		1.00

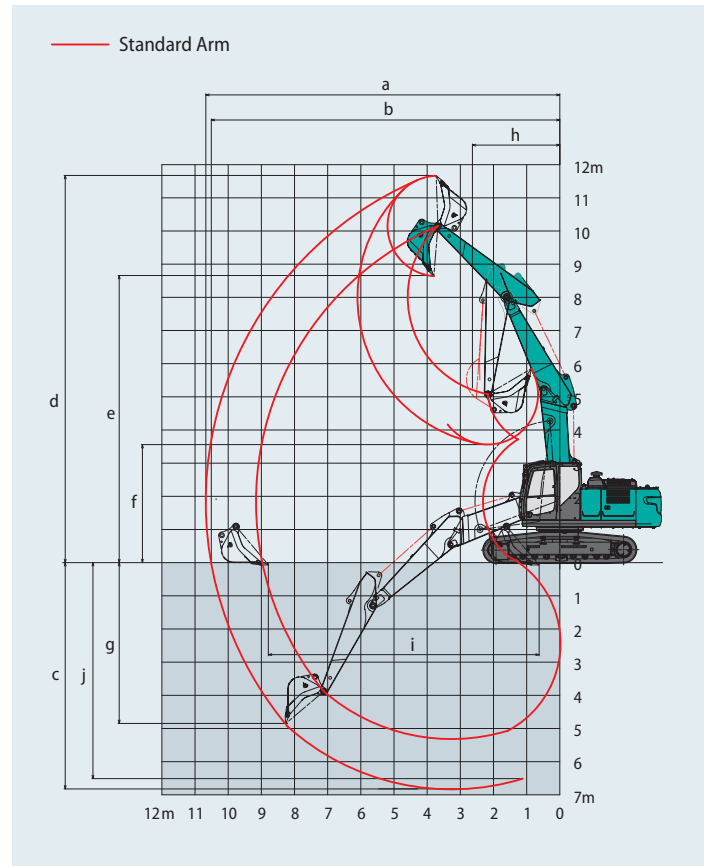

Digging Force (ISO 6015)

Unit: kN

Arm length	Standard 2.98 m
Bucket digging force	170 187*
Arm crowding force	122 134*

*Power Boost engaged.



Dimensions

Arm length		Standard 2.98 m
A Overall length		10,570
B Overall height (to top of boom)		3,050
C Overall width of crawler	SK260LC	3,190
	SK260NLC	2,990
D Overall height (to top of cab)		3,090
E Ground clearance of rear end*		1,090
F Ground clearance*		440

Unit: mm

G Tail swing radius		3,100
G' Distance from centre of swing to rear end		3,070
H Tumbler distance		3,850
I Overall length of crawler		4,640
J Track gauge	SK260LC	2,590
	SK260NLC	2,390
K Shoe width		600
L Overall width of upperstructure		2,980

*Without including height of shoe lug

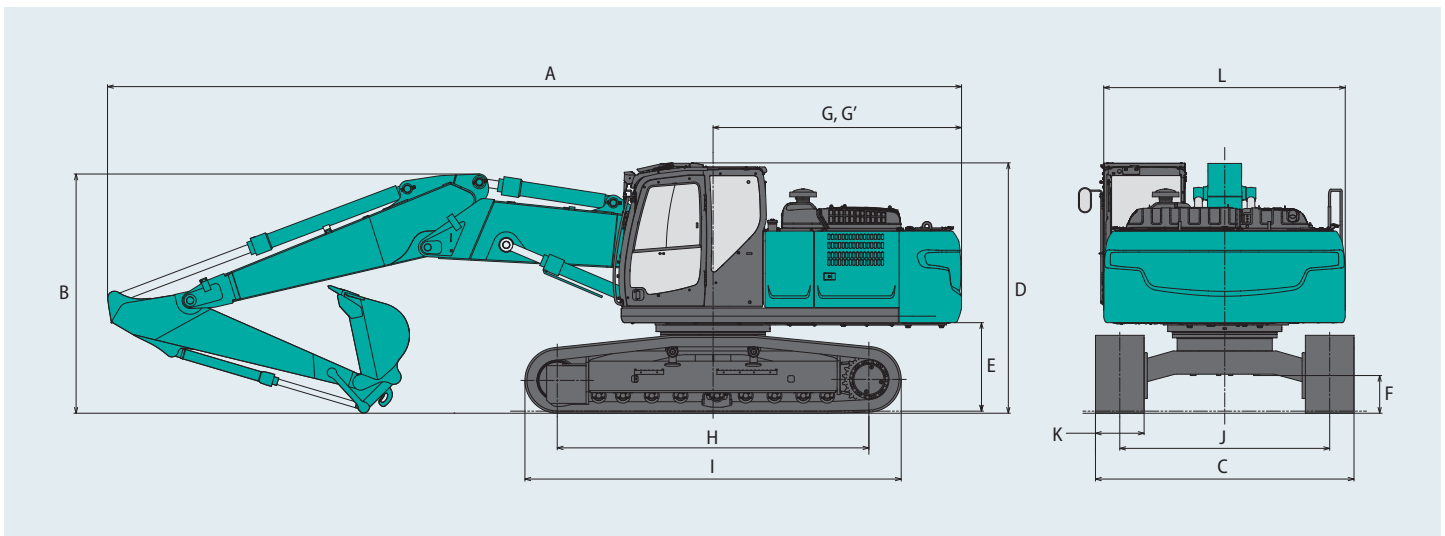

Operating weight & ground pressure

In standard trim, with 2 Piece Boom, 2.98 m arm, and 1.00 m³ ISO heaped bucket.

Shaped			Triple grouser shoes (even height)			
Shoe width	mm		600	700	800	900
Overall width of crawler	SK260LC	mm	3,190	3,290	3,390	3,490
	SK260NLC	mm	2,990	3,090	3,190	—
Ground pressure	SK260LC	kPa	55	47	42	38
	SK260NLC	kPa	55	47	42	—
Operating weight	SK260LC	kg	27,700	28,000	28,300	28,500
	SK260NLC	kg	27,600	27,900	28,200	—

Lift Capacities

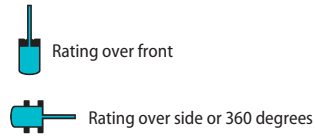
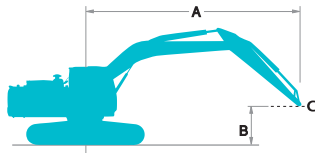

A: Reach from swing centreline to arm top
 B: Arm top height above/below ground
 C: Lift point
 Bucket: Without bucket
 Relief valve setting: 37.8 MPa

SK260LC		2 Piece Boom		Arm: 2.98 m		Bucket: without		Counterweight: 5,580 kg		Shoe: 600 mm (Heavy Lift)				
B	A	1.5 m		3.0 m		4.5 m		6.0 m		7.5 m		At max. reach		
														Radius
7.5 m	kg							*7,300	*7,300			*4,700	*4,700	7.14 m
6.0 m	kg					*8,300	*8,300	*7,600	7,400	*6,700	5,000	*4,200	*4,200	8.12 m
4.5 m	kg			*15,300	*15,300	*10,300	*10,300	*8,200	7,000	*6,900	5,100	*4,000	3,800	8.73 m
3.0 m	kg			*10,300	*10,300	*12,000	*10,100	*8,900	6,800	7,000	4,800	*3,900	3,500	9.06 m
1.5 m	kg			*16,800	*16,800	*12,800	*10,000	*9,400	6,800	7,000	*4,800	*4,000	3,400	9.12 m
G.L.	kg	*10,600	*10,600	*18,900	18,200	*12,800	9,600	*9,300	6,400	6,700	4,500	*4,200	3,400	8.94 m
-1.5 m	kg	*14,900	*14,900	*20,200	17,800	*13,000	9,200	9,500	6,100	6,600	4,500	*4,700	3,700	8.48 m
-3.0 m	kg	*26,700	*26,700	*19,600	17,900	*13,000	9,100	*9,300	5,900	*5,900	4,300	*5,300	4,200	7.71 m
-4.5 m	kg	*26,800	*26,800	*17,000	*17,000	*10,700	9,100	*6,200	5,900			*5,600	*5,600	6.20 m

SK260NLC		2 Piece Boom		Arm: 2.98 m		Bucket: without		Counterweight: 5,580 kg		Shoe: 600 mm (Heavy Lift)				
B	A	1.5 m		3.0 m		4.5 m		6.0 m		7.5 m		At max. reach		
														Radius
7.5 m	kg							*7,300	6,900			*4,700	*4,700	7.14 m
6.0 m	kg					*8,300	*8,300	*7,600	6,800	*6,700	*4,700	*4,200	4,000	8.12 m
4.5 m	kg			*15,300	*15,300	*10,300	10,000	*8,200	6,700	*6,900	4,700	*4,000	3,400	8.73 m
3.0 m	kg			*10,300	*10,300	*12,000	9,500	*8,900	*6,500	7,000	*4,400	*3,900	3,100	9.06 m
1.5 m	kg			*16,800	*16,800	*12,800	9,400	*9,400	6,200	7,000	4,400	*4,000	3,000	9.12 m
G.L.	kg	*10,600	*10,600	*18,900	16,000	*12,800	8,700	*9,300	5,800	6,700	4,100	*4,200	3,000	8.94 m
-1.5 m	kg	*14,900	*14,900	*20,200	15,600	*13,000	8,300	9,500	5,500	6,600	4,100	*4,700	3,200	8.48 m
-3.0 m	kg	*26,700	*26,700	*19,600	15,700	*13,000	8,200	*9,300	5,300	*5,900	3,900	*5,200	3,700	7.71 m
-4.5 m	kg	*26,800	*26,800	*17,000	16,200	*10,700	8,200	*6,200	5,400			*5,500	5,200	6.20 m

Notes:

- Do not attempt to lift or hold any load that is greater than these lift capacities at their specified lift point radius and heights. Weight of all accessories must be deducted from the above lift capacities.
- Lift capacities are based on machine standing on level, firm, and uniform ground. User must make allowance for job conditions such as soft or uneven ground, out of level conditions, side loads, sudden stopping of loads, hazardous conditions, experience of personnel, etc.
- Arm top defined as lift point.
- The above lift capacities are in compliance with ISO 10567. They do not exceed 87% of hydraulic lift

capacity or 75% of tipping load. Lift capacities marked with an asterisk(*) are limited by hydraulic capacity rather than tipping load.

- Operator should be fully acquainted with the Operator's and Maintenance Instructions before operating this machine. Rules for safe operation of equipment should be adhered to at all times.
- Lift capacities apply to only machine as originally manufactured and normally equipped by KOBELCO CONSTRUCTION MACHINERY CO., LTD.

Long Reach Attachment Specifications



Working Ranges

Unit: mm

Boom		10.35 m
	Arm	8.25 m
Range		
a- Max. digging reach		18,530
b- Max. digging reach at ground level		18,440
c- Max. digging depth		14,730
d- Max. digging height		14,590
e- Max. dumping clearance		12,320
f- Min. dumping clearance		1,570
g- Max. vertical wall digging depth		12,380
h- Min. swing radius		5,600
i- Horizontal digging stroke at ground level		14,770
j- Digging depth for 2.4 m (8') flat bottom		14,590
Bucket capacity ISO heaped m ³		0.40

Digging Force (ISO 6015)

Unit: kN

Arm length	Standard 8.25 m
Bucket digging force	88
Arm crowding force	52

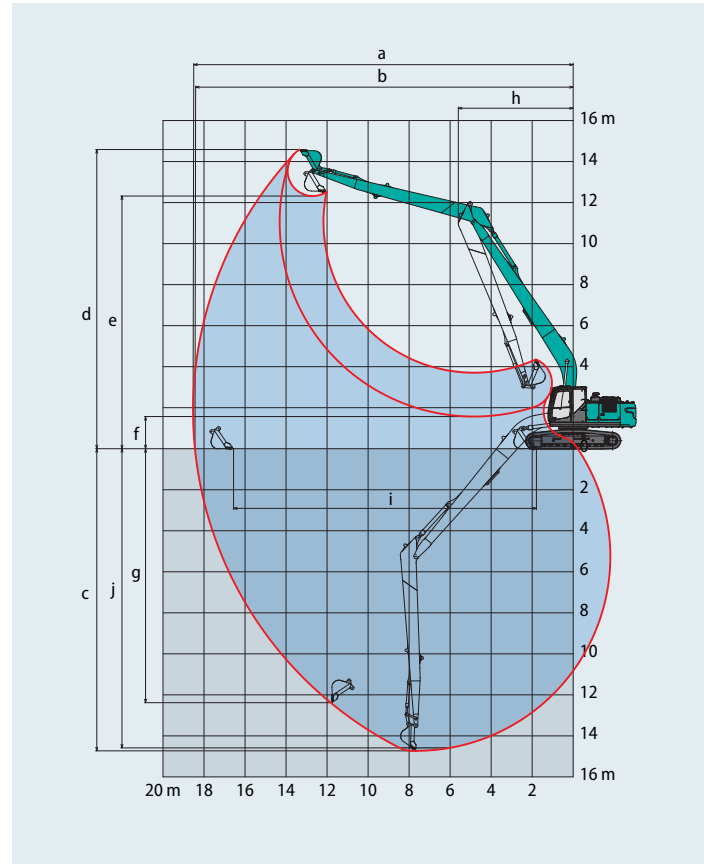



Dimensions

Arm length		Standard 8.25 m	
A	Overall length	14,520	
B	Overall height (to top of boom)	3,190	
C	Overall width of crawler	SK260LC	3,190
		SK260NLC	2,990
D	Overall height (to top of cab)	3,090	
E	Ground clearance of rear end*	1,090	
F	Ground clearance*	440	

		Unit: mm	
G	Tail swing radius	3,100	
G'	Distance from centre of swing to rear end	3,070	
H	Tumbler distance	3,850	
I	Overall length of crawler	4,640	
J	Track gauge	SK260LC	2,590
		SK260NLC	2,390
K	Shoe width	600	
L	Overall width of upperstructure	2,980	

*Without including height of shoe lug

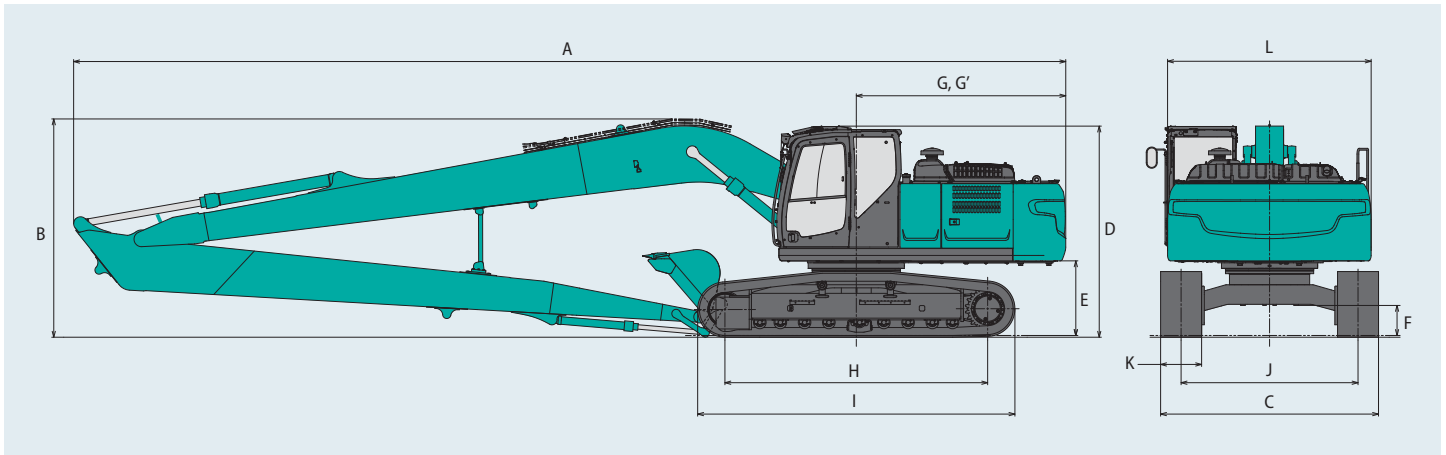

Operating Weight & Ground Pressure

In standard trim, with 10.35 m boom, 8.25 m arm, and 0.40 m³ ISO heaped bucket.

Shaped			Triple grouser shoes (even height)			
Shoe width		mm	600	700	800	900
Overall width of crawler	SK260LC	mm	3,190	3,290	3,390	3,490
	SK260NLC	mm	2,990	3,090	3,190	—
Ground pressure	SK260LC	kPa	55	48	42	38
	SK260NLC	kPa	55	48	42	—
Operating weight	SK260LC	kg	28,000	28,300	28,600	28,900
	SK260NLC	kg	27,900	28,200	28,500	—

Lift Capacities

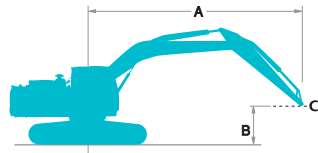

Rating over front



Rating over side or 360 degrees

A - Reach from swing centerline to arm top
 B - Arm top height above/below ground
 C - Lift point
 Bucket : Without bucket
 Relief valve setting: 34.3 MPa

SK260LC		Boom: 10.35m Arm: 8.25m Bucket: without Counterweight: 6,780 kg Shoe: 600mm																													
B	A	1.5 m		3.0 m		4.5 m		6.0 m		7.5 m		9.0 m		10.5 m		12.0 m		13.5 m		15.0 m		16.5 m		At max. reach		Radius					
		Rating over front	Rating over side or 360 degrees	Rating over front	Rating over side or 360 degrees	Rating over front	Rating over side or 360 degrees	Rating over front	Rating over side or 360 degrees	Rating over front	Rating over side or 360 degrees	Rating over front	Rating over side or 360 degrees	Rating over front	Rating over side or 360 degrees	Rating over front	Rating over side or 360 degrees	Rating over front	Rating over side or 360 degrees	Rating over front	Rating over side or 360 degrees	Rating over front	Rating over side or 360 degrees	Rating over front	Rating over side or 360 degrees						
13.5 m	kg																								*980	*980	12.76m				
12.0 m	kg																	*1,210	*1,210							*940	*940	13.99m			
10.5 m	kg																	*1,600	*1,600							*910	*910	14.97m			
9.0 m	kg																	*1,680	*1,680	*1,360	*1,360					*900	*900	15.75m			
7.5 m	kg																	*1,750	*1,750	*1,670	*1,670					*910	*910	16.35m			
6.0 m	kg																		*1,920	*1,920	*1,850	*1,850	*1,790	*1,790	*1,160	*1,160	*930	*930	16.80m		
4.5 m	kg														*2,260	*2,260	*2,090	*2,090	*1,970	*1,970	*1,880	1,750	*1,430	1,410	*960	*960	17.10m				
3.0 m	kg			*9,220	*9,220														*2,260	*2,260	*2,280	*2,280	*2,110	2,050	*1,980	1,670	*1,630	1,350	*1,000	*1,000	17.26m
1.5 m	kg			*2,630	*2,630	*7,310	*7,310	*5,080	*5,080	*3,930	*3,930	*3,240	*3,240	*2,800	*2,800	*2,480	2,370	*2,260	1,930	*2,090	1,580	*1,770	1,290	*1,060	*1,060	*1,140	*1,130	17.30m			
G.L.	kg			*2,400	*2,400	*5,030	*5,030	*5,860	5,730	*4,450	4,310	*3,610	3,370	*3,060	2,700	*2,680	2,200	*2,400	1,810	*2,200	1,490	*1,840	1,240	*1,140	*1,130	17.20m					
-1.5 m	kg	*2,140	*2,140	*2,830	*2,830	*4,600	*4,600	*6,420	5,210	*4,880	3,930	*3,930	3,100	*3,300	2,510	*2,860	2,060	*2,540	1,700	*2,290	1,420	*1,780	1,190	*1,240	1,120	*1,240	1,120	16.97m			
-3.0 m	kg	*2,780	*2,780	*3,410	*3,410	*4,850	*4,850	*6,760	4,920	*5,180	3,680	*4,170	2,900	*3,490	2,350	*3,000	1,940	*2,650	1,620	2,300	1,360	*1,510	1,150	*1,370	1,140	*1,370	1,140	16.60m			
-4.5 m	kg	*3,440	*3,440	*4,070	*4,070	*5,390	*5,390	*6,920	4,780	*5,360	3,540	*4,330	2,770	*3,620	2,250	3,100	1,860	2,630	1,560	2,260	1,320				*1,540	1,180	16.08m				
-6.0 m	kg	*4,110	*4,110	*4,800	*4,800	*6,100	*6,100	*6,920	4,750	*5,420	3,470	*4,410	2,710	3,670	2,190	3,060	1,820	2,600	1,530	2,250	1,310				*1,790	1,260	15.40m				
-7.5 m	kg	*4,820	*4,820	*5,590	*5,590	*6,960	*6,960	*6,770	4,800	*5,360	3,480	*4,390	2,700	3,660	2,180	3,050	1,810	2,610	1,540							*2,150	1,390	14.53m			
-9.0 m	kg	*5,580	*5,580	*6,470	*6,470	*7,990	7,670	*6,460	4,920	*5,160	3,560	*4,250	2,750	*3,570	2,220	*3,030	1,850									*2,580	1,600	13.44m			
-10.5 m	kg	*6,390	*6,390	*7,440	*7,440	*7,690	*7,690	*5,950	5,120	*4,800	3,690	*3,960	2,850	*3,310	2,310	*2,750	1,950									*2,720	1,940	12.06m			
-12.0 m	kg			*8,530	*8,530	*6,580	*6,580	*5,160	*5,160	*4,190	3,900	*3,440	3,030													*2,870	2,550	10.28m			

SK260NLC		Boom: 10.35m Arm: 8.25m Bucket: without Counterweight: 6,780 kg Shoe: 600mm																														
B	A	1.5 m		3.0 m		4.5 m		6.0 m		7.5 m		9.0 m		10.5 m		12.0 m		13.5 m		15.0 m		16.5 m		At max. reach		Radius						
		Rating over front	Rating over side or 360 degrees	Rating over front	Rating over side or 360 degrees	Rating over front	Rating over side or 360 degrees	Rating over front	Rating over side or 360 degrees	Rating over front	Rating over side or 360 degrees	Rating over front	Rating over side or 360 degrees	Rating over front	Rating over side or 360 degrees	Rating over front	Rating over side or 360 degrees	Rating over front	Rating over side or 360 degrees	Rating over front	Rating over side or 360 degrees	Rating over front	Rating over side or 360 degrees	Rating over front	Rating over side or 360 degrees							
13.5 m	kg																									*980	*980	12.76m				
12.0 m	kg																		*1,210	*1,210							*940	*940	13.99m			
10.5 m	kg																		*1,600	*1,600							*910	*910	14.97m			
9.0 m	kg																		*1,680	*1,680	*1,360	*1,360					*900	*900	15.75m			
7.5 m	kg																		*1,750	*1,750	*1,670	*1,670					*910	*910	16.35m			
6.0 m	kg																			*1,920	*1,920	*1,850	*1,850	*1,790	1,670	*1,160	*1,160	*930	*930	16.80m		
4.5 m	kg																			*2,260	*2,260	*2,090	*2,090	*1,970	*1,970	*1,880	1,590	*1,430	1,260	*960	*960	17.10m
3.0 m	kg			*9,220	*9,220															*2,260	*2,260	*2,280	*2,280	*2,110	1,870	*1,980	1,500	*1,630	1,210	*1,000	*1,000	17.26m
1.5 m	kg			*2,630	*2,630	*7,310	*7,310	*5,080	*5,080	*3,930	*3,930	*3,240	*3,240	*2,800	2,680	*2,480	2,150	*2,260	1,740	*2,090	1,410	*1,770	1,150	*1,060	1,150	*1,060	1,020	17.30m				
G.L.	kg			*2,400	*2,400	*5,030	*5,030	*5,860	5,160	*4,450	3,900	*3,610	3,060	*3,060	2,450	*2,680	1,980	*2,400	1,620	*2,200	1,330	*1,840	1,090	*1,140	990	17.20m						
-1.5 m	kg	*2,140	*2,140	*2,830	*2,830	*4,600	*4,600	*6,420	4,660	*4,880	3,530	*3,930	2,790	*3,300	2,250	*2,860	1,840	*2,540	1,520	*2,290	1,250	*1,780	1,040	*1,240	980	16.97m						
-3.0 m	kg	*2,780	*2,780	*3,410	*3,410	*4,850	*4,850	*6,760	4,370	*5,180	3,280	*4,170	2,590	*3,490	2,100	*3,000	1,730	*2,650	1,430	2,290	1,200	*1,510	1,010	*1,370	990	16.60m						
-4.5 m	kg	*3,440	*3,440	*4,070	*4,070	*5,390	*5,390	*6,920	4,230	*5,360	3,140	*4,330	2,460	*3,620	2,000	3,090	1,650	2,620	1,370	2,250	1,160				*1,540	1,030	16.08m					
-6.0 m	kg	*4,110	*4,110	*4,800	*4,800	*6,100	*6,100	*6,920	4,200	*5,420	3,080	*4,410	2,400	3,660	1,940	3,050	1,600	2,590	1,350	2,240	1,150				*1,790	1,110	15.40m					
-7.5 m	kg	*4,820	*4,820	*5,590	*5,590	*6,960	6,560	*6,770	4,250	*5,360	3,090	*4,390	2,390	3,650	1,930	3,040	1,600	2,600	1,350							*2,150	1,220	14.53m				
-9.0 m	kg	*5,580	*5,580	*6,470	*6,470	*7,990	6,780	*6,460	4,370	*5,160	3,160	*4,250	2,440	*3,570	1,970	*3,030	1,640									*2,580	1,410	13.44m				
-10.5 m	kg	*6,390	*6,390	*7,440	*7,440	*7,690	7,090	*5,950	4,560	*4,800	3,290	*3,960	2,540	*3,310	2,060	*2,750	1,730									*2,720	1,720	12.06m				
-12.0 m	kg			*8,530	*8,530	*6,580	*6,580	*5,160	4,840	*4,190	3,500	*3,440	2,720													*2,870	2,290	10.28m				

Notes:

- Do not attempt to lift or hold any load that is greater than these lift capacities at their specified lift point radius and heights. Weight of all accessories must be deducted from the above lift capacities.
- Lift capacities are based on machine standing on level, firm, and uniform ground. User must make allowance for job conditions such as soft or uneven ground, out of level conditions, side loads, sudden stopping of loads, hazardous conditions, experience of personnel, etc.
- Arm top defined as lift point.
- The above lift capacities are in compliance with ISO 10567. They do not exceed 87% of hydraulic lift capacity or 75% of tipping load. Lift capacities marked with an asterisk (*) are limited by hydraulic capacity rather than tipping load.
- Operator should be fully acquainted with the Operator's and Maintenance Instructions before operating this machine. Rules for safe operation of equipment should be adhered to at all times.
- Lift capacities apply to only machine as originally manufactured and normally equipped by KOBELCO CONSTRUCTION MACHINERY CO., LTD.

Standard and Optional Equipment

● = Std ○ = Opt — = N/A

Category	Description	SK260(N)LC-11E				
		Mono Boom / 2 Piece Boom		Long Reach		
		LC	NLC	LC	NLC	
ENGINE	YANMAR 4TN107FTT (EU Stage V compliant)	●	●	●	●	
	Exhaust DOC DPF SCR system	●	●	●	●	
	Alternator 24 V / 80 A	●	●	●	●	
	Starter motor 24 V / 5 kW	●	●	●	●	
	Batteries 2 x 12 V (130 Ah)	●	●	●	●	
	Fan suction type cooling system	●	●	●	●	
	Auto deceleration function	●	●	●	●	
	Auto Idle Stop (AIS)	●	●	●	●	
HYDRAULIC SYSTEM	3 work modes H, S, Eco	●	●	-	-	
	Power boost (37.8 MPa)	●	●	-	-	
	Heavy lift mode	●	●	-	-	
	Pressure release function	●	●	●	●	
	Independent travel function	●	●	●	●	
	Auto warm up system	●	●	●	●	
	Proportional Hand Control (for E&N&B piping)	●	●	-	-	
	Proportional Hand Control (for Extra piping)	-	-	-	-	
	Hydraulic oil VG32	●	●	●	●	
	Hydraulic oil VG46	○	○	○	○	
	Hydraulic oil VG68	○	○	○	○	
	PIPING	E & N&B piping	●	●	-	-
E & N&B piping + Bigger capacity P4 pump (93.9 L/min)		○	○	-	-	
Standard piping (only mono Boom spec)		○	-	-	-	
Extra piping		-	-	●	●	
QH piping		●	●	●	●	
CABIN	Air suspension seat with heating	●	●	●	●	
	10 inch colour monitor	●	●	●	●	
	LED door light	●	●	●	●	
	Air-conditioner	●	●	●	●	
	DAB+ radio (FM/AM & AUX & USB & Bluetooth* & hands free telephone)	●	●	●	●	
	Harness for CAB four lights and CAB yellow flasher	●	●	●	●	
	Parallel wiper	●	●	●	●	
	12 V power outlet	●	●	●	●	
	Rain visor	○	○	○	○	
	Sun screen	●	●	●	●	
	Large footrest	●	●	●	●	
	LIGHTS	LED work lights ; 2 on Boom, 1 on upper frame, 2 on rear counterweight	●	●	●	●
		LED work lights ; 2 on Cab top front	○	○	○	○
WORKING EQUIPMENT	Standard Boom (6.02 m)	●	●	-	-	
	2 Piece Boom	○	○	-	-	
	Long Reach (60 ft)	-	-	●	●	
	Standard HD arm (2.98 m) with rock guard	●	●	-	-	
	Short HD arm (2.50 m) with rock guard	○	○	-	-	
	Long HD arm (3.66 m) with rock guard	○	○	-	-	
	Long Reach arm (8.25 m)	-	-	●	●	
	Bucket link with lifting hook	●	●	●	●	
COUNTERWEIGHT	Standard C/W (TTL 5,580 kg)	●	●	-	-	
	Heavier C/W (TTL 6,780 kg)	-	-	●	●	
UNDERCARRIAGE	600 mm steel shoe	●	●	●	●	
	700 mm steel shoe	○	○	○	○	
	800 mm steel shoe	○	○	○	○	
	900 mm steel shoe	○	-	○	-	
	Track guide (one per side)	●	●	●	●	
	Additional track guides (two additional per side)	○	○	○	○	
SAFETY	Lower frame guard	●	●	●	●	
	Engine emergency stop switch	●	●	●	●	
	Pump emergency mode (KPSS release switch)	●	●	●	●	
	Emergency accel dial	●	●	●	●	
	Emergency manual valve for lowering attachment	●	●	●	●	
	Overload alarm	●	●	●	●	
	Safety valve for Boom & arm cylinder	●	●	●	●	
	ROPS compliant cab (ISO 12117-2:2008)	●	●	●	●	
	OPG Level II top guard (ISO 10262:1998)	●	●	●	●	
	OPG Level II front guard (ISO 10262:1998)	○	○	○	○	
	Eagle-eye view camera (Rear, Right, Left)	●	●	●	●	
	Seatbelt indicator on display	●	●	●	●	
	Travel alarm	○	○	○	○	
	Extended handrail	○	○	○	○	
Emergency escape hammer	●	●	●	●		
OTHERS	Refueling pump	●	●	●	●	
	Harness for engine room light	●	●	●	●	
	RAL color	○	○	○	○	
	KOMEXS	●	●	●	●	

*The air conditioning system on this machine contains fluorinated greenhouse gas HFC-134a (GWP 1430). Quantity of gas 0.8 kg (CO2 equivalent 1.2 t).

Note: Bluetooth* is a registered trademark of the Bluetooth SIG Inc.

Note: This catalogue may contain attachments and optional equipment that are not available in your area. And it may contain photographs of machines with specifications that differ from those of machines sold in your areas. Please consult your nearest KOBELCO distributor for those items you require.

Specialist equipment is needed to use this machine in demolition work. Before using it please contact your KOBELCO dealer.

Due to our policy of continuous product improvements all designs and specifications are subject to change without advance notice.

Copyright by **KOBELCO CONSTRUCTION MACHINERY CO., LTD.** No part of this catalogue may be reproduced in any manner without notice.

KOBELCO CONSTRUCTION MACHINERY EUROPE B.V.

Veluwezooom 15
1327 AE Almere
The Netherlands
www.kobelco-europe.com

Enquiries To: