

KOBELCO

SK260LC-11E SK260NLC-11E
SK300LC-11E SK300NLC-11E
SK350LC-11E SK350NLC-11E

Performance  Design

Straight Boom

SK260_{LC} **SK260_{NLC}**
SK300_{LC} **SK300_{NLC}**
SK350_{LC} **SK350_{NLC}**



■ Engine power

SK260(N)LC: 155 kW / 2,200 min⁻¹
SK300(N)LC: 210 kW / 1,900 min⁻¹
SK350(N)LC: 210 kW / 1,900 min⁻¹

■ Operating weight

SK260(N)LC: 26,800 – 27,700 kg
SK300(N)LC: 31,500 – 33,000 kg
SK350(N)LC: 37,100 – 38,800 kg



Complies with the EU Stage V
exhaust emission regulation

Built for Perfectionists

Perfect for mid-height demolitions. Exceptional efficiency with an extended reach and wider working range.

Reach new heights with the straight boom.

The straight shaped boom is designed to reach taller buildings and higher areas with greater precision and efficiency than the standard boom.

Max. working height to arm top		
	Standard arm	Long arm
SK260(N)LC-11E	10,550 mm	11,220 mm
SK300(N)LC-11E	10,950 mm	11,770 mm
SK350(N)LC-11E	11,320 mm	11,940 mm





**Tough and reliable:
Built to get the job done in even the
most challenging conditions.**

Additional track guides are fitted as standard for stable movement even on unstable ground. An under cover prevents damage when moving over rubble and an arm rock guard protects the arm from damage.

A handy lifting hook on the bucket link allows for lifting operations, and the model SK300 is equipped with semi heavier counterweight as standard for extra stability and lifting capacity.

**Greater flexibility:
Equipped with a drain circuit for more
attachments.**

Equipped with a drain circuit as standard, our latest excavator can now accommodate attachments that require drainage. This increases the choice of compatible various attachments.

**Unrivalled safety:
Designed to protect drivers and
improve construction site safety.**

Work smarter and safer on-site. In addition to the ROPS cab, front guard, and top guard helps ensure operator safety, while an optional travel alarm alerts surrounding workers. LED lights on the cab, boom, and counterweight improve visibility, and the Eagle Eye View system offers a wide field of vision, for unrivalled safety.

Specifications



Engine

Model	YANMAR 4TN107FTT
Type	Four-cycle, water-cooled, direct injection diesel engine, turbo charged, EU Stage V exhaust emission regulation
No. of cylinders	4
Bore and stroke	107 mm x 127 mm
Displacement	4.567 L
Rated power output	148 kW/2,200 min ⁻¹ (ISO 9249 : with fan)
	155 kW/2,200 min ⁻¹ (ISO 14396: without fan)
Max. torque	792 N-m/1,500 min ⁻¹ (ISO 9249: with fan)
	805 N-m/1,500 min ⁻¹ (ISO 14396: without fan)



Hydraulic System

Pump	
Type	Two variable displacement axial piston pumps + extra gear pump + pilot gear pump
Max. discharge flow	2 x 245 L/min, 1 x 42.6 L/min, 1 x 21 L/min
Relief valve setting	
Boom, arm and bucket	34.3 MPa
Power Boost	37.8 MPa
Travel circuit	34.3 MPa
Swing circuit	28.4 MPa
Control circuit	5.0 MPa
Pilot control pump	Gear type
Main control valve	8-spool
Oil cooler	Air cooled type



Swing System

Swing motor	One fixed displacement piston motor
Brake	Hydraulic; locking automatically when the swing control lever is in the neutral position
Parking brake	Wet multiple plate
Swing speed	11.4 min ⁻¹
Swing torque	85.9 kN-m
Maximum swing gradient (Loaded)*	26 % {15°}

*Value for the least favourable specification



Travel System

Travel motors	2 × axial-piston, two-step motors
Travel brakes	Hydraulic brake per motor
Parking brakes	Oil disc brake per motor
Travel shoes	51 each side
Travel speed	5.8/3.6 km/h
Rated drawbar pull	243 kN (SAE J 1309)
Gradeability	70 % {35°}



Cab & Control

Cab

All-weather, sound-suppressed steel cab mounted on the high suspension mounts filled with silicone oil and equipped with a heavy, insulated floor mat.

Control

Two hand levers and two foot pedals for travel

Two hand levers for excavating and swing

Electric rotary-type engine throttle

Noise levels

External 104 dB(A) (2000/14/EC)

Operator 76 dB(A) (ISO 6396)

Vibration levels

Hand/arm* ≤ 2.5 m/s²

Body* ≤ 0.5 m/s²

*For the risk assessment according to 2002/44/EC, refer to ISO/TR 25398: 2006



Cylinders

Boom cylinders	135 mm × 1,235 mm
Arm cylinder	145 mm × 1,635 mm
Bucket cylinder	125 mm × 1,200 mm



Refilling Capacities & Lubrications

Fuel tank	403 L
Cooling system	23 L
Engine oil	20 L
Travel reduction gear	2 × 4.5 L
Swing reduction gear	1 × 5.0 L
Hydraulic oil tank	165 L tank oil level
	273 L hydraulic system
DEF/Urea tank	83 L



Working Ranges

Unit: mm

Range	Arm	Straight boom	
		Standard 2.98 m	Long 3.66 m
a- Max. digging reach		10,520	11,210
b- Max. digging reach at ground level		10,360	11,050
c- Max. digging depth		4,900	5,580
d- Max. digging height		12,070	12,730
d'- Max. working height to arm top		10,550	11,220
e- Max. dumping clearance		9,170	9,850
f- Min. dumping clearance		3,760	3,140
g- Max. vertical wall digging depth		4,200	4,870
h- Min. swing radius		2,600	2,890
i- Horizontal digging stroke at ground level		4,920	5,960
j- Digging depth for 2.4 m (8') flat bottom		4,730	5,440
Bucket capacity ISO heaped m ³		1.00	0.80

Digging Force (ISO 6015)

Unit: kN

Arm length	Standard 2.98 m	Long 3.66 m
Bucket digging force	170 187*	170 187*
Arm crowding force	122 134*	104 114*

*Power Boost engaged

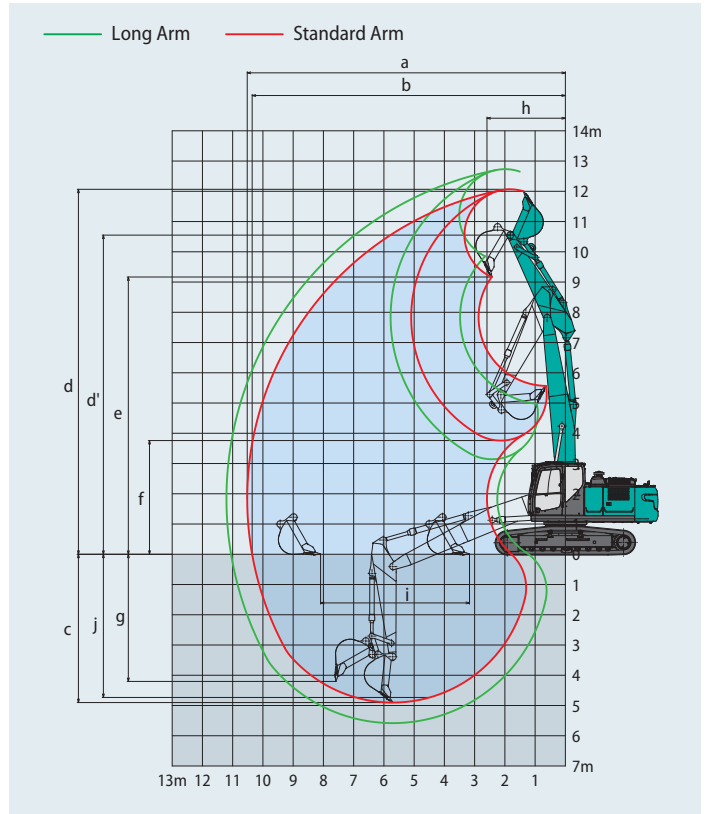

Dimensions

Arm length		Standard 2.98 m	Long 3.66 m
A Overall length		10,210	10,100 (10,200**)
B Overall height (to top of boom)		2,980	3,600 (2,990**)
C Overall width of crawler	SK260LC	3,190	
	SK260NLC	2,990	
D Overall height (to top of cab)		3,090	
E Ground clearance of rear end*		1,090	
F Ground clearance*		440	

Unit: mm

G Tail swing radius		3,100
G' Distance from centre of swing to rear end		3,070
H Tumbler distance		3,850
I Overall length of crawler		4,640
J Track gauge	SK260LC	2,590
	SK260NLC	2,390
K Shoe width		600
L Overall width of upperstructure		2,980

*Without including height of shoe lug ** Without bucket

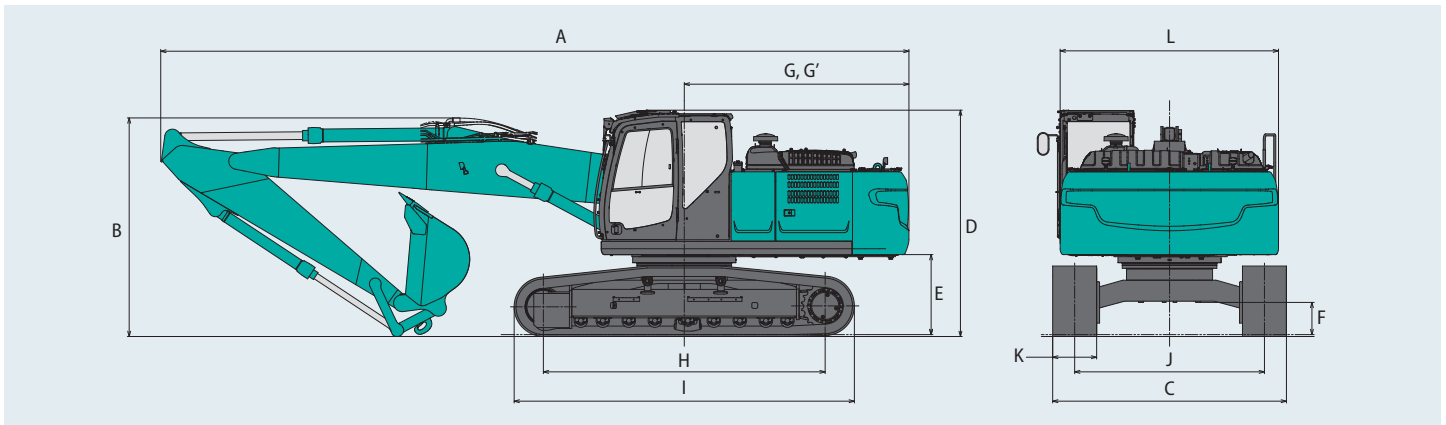

Operating Weight & Ground Pressure

In standard trim, with Straight boom, 2.98 m arm, and 1.00 m³ ISO heaped bucket

Shaped		Triple grouser shoes (even height)			
		600	700	800	900
Overall width of crawler	SK260LC	3,190	3,290	3,390	3,490
	SK260NLC	2,990	3,090	3,190	—
Ground pressure	SK260LC	53	46	41	37
	SK260NLC	53	46	41	—
Operating weight	SK260LC	26,800	27,100	27,400	27,700
	SK260NLC	26,700	27,000	27,300	—

Lift Capacities

SK260^{LC} **SK260^{NLC}**
SK260LC-11E SK260NLC-11E

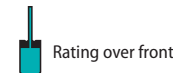
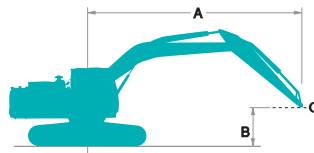

Rating over front



Rating over side or 360 degrees

A - Reach from swing centreline to arm top

B - Arm top height above/below ground

C - Lift point

Relief valve setting: 37.8 MPa

SK260LC		Straight boom		Arm: 2.98 m		Bucket: without		Counterweight: 5,580 kg		Shoe: 600 mm (Heavy Lift)				
B	A	3.0 m		4.5 m		6.0 m		7.5 m		At max. reach		Radius		
10.5 m	kg											*11,140	*11,140	2.17 m
9.0 m	kg			*8,310	*8,310							*6,290	*6,290	5.40 m
7.5 m	kg			*7,470	*7,470	*7,670	7,470					*5,240	*5,240	6.98 m
6.0 m	kg	*5,920	*5,920	*7,290	*7,290	*7,970	7,370	*7,060	5,100			*4,790	4,550	7.97 m
4.5 m	kg			*10,070	*10,070	*8,880	7,090	7,470	5,000			*4,610	3,980	8.60 m
3.0 m	kg					*9,590	6,720	7,280	4,830			*4,600	3,690	8.93 m
1.5 m	kg			*13,720	9,600	9,950	6,390	7,100	4,670			*4,740	3,600	8.99 m
G.L.	kg			*13,360	9,310	9,720	6,180	6,980	4,560			*5,050	3,690	8.80 m
-1.5 m	kg	*8,610	*8,610	*11,920	9,300	*9,170	6,130	6,970	4,540			*5,430	4,000	8.34 m
-3.0 m	kg			*9,440	*9,440	*7,370	6,220					*4,500	*4,500	7.55 m

SK260LC		Straight boom		Arm: 3.66 m		Bucket: without		Counterweight: 5,580 kg		Shoe: 600 mm (Heavy Lift)				
B	A	3.0 m		4.5 m		6.0 m		7.5 m		9.0 m		At max. reach		
														Radius
10.5 m	kg											*6,200	*6,200	4.23 m
9.0 m	kg			*6,450	*6,450	*5,910	*5,910					*4,450	*4,450	6.49 m
7.5 m	kg			*5,520	*5,520	*6,010	*6,010	*5,220	4,850			*3,820	*3,820	7.85 m
6.0 m	kg			*5,170	*5,170	*5,960	*5,960	*6,070	4,860			*3,520	*3,520	8.74 m
4.5 m	kg	*4,930	*4,930	*6,220	*6,220	*6,760	*6,760	*6,720	4,720	*5,040	3,450	*3,380	3,220	9.31 m
3.0 m	kg			*11,880	9,930	*9,080	6,380	6,910	4,520	5,170	3,370	*3,350	3,010	9.62 m
1.5 m	kg			*13,290	9,120	9,450	5,990	6,690	4,320	5,070	3,280	*3,430	2,940	9.68 m
G.L.	kg			*13,550	8,660	9,140	5,720	6,520	4,170	5,000	3,220	*3,620	3,000	9.50 m
-1.5 m	kg	*7,940	*7,940	*12,650	8,530	9,010	5,600	6,450	4,110	*4,920	3,240	*3,960	3,210	9.08 m
-3.0 m	kg			*10,690	8,610	*8,200	5,620	*6,060	4,150			*4,300	3,660	8.36 m

SK260NLC		Straight boom		Arm: 2.98 m		Bucket: without		Counterweight: 5,580 kg		Shoe: 600 mm (Heavy Lift)				
B	A	3.0 m		4.5 m		6.0 m		7.5 m		At max. reach		Radius		
10.5 m	kg											*11,140	*11,140	2.17 m
9.0 m	kg			*8,310	*8,310							*6,290	*6,290	5.40 m
7.5 m	kg			*7,470	*7,470	*7,670	6,870					*5,240	5,230	6.98 m
6.0 m	kg	*5,920	*5,920	*7,290	*7,290	*7,970	6,770	*7,060	4,680			*4,790	4,170	7.97 m
4.5 m	kg			*10,070	*10,070	*8,880	6,490	7,420	4,580			*4,610	3,630	8.60 m
3.0 m	kg			*12,770	9,300	*9,590	6,130	7,230	4,420			*4,600	3,370	8.93 m
1.5 m	kg			*13,720	8,650	9,880	5,810	7,050	4,250			*4,740	3,280	8.99 m
G.L.	kg			*13,360	8,370	9,650	5,610	6,930	4,150			*5,050	3,360	8.80 m
-1.5 m	kg	*8,610	*8,610	*11,920	8,360	*9,170	5,550	6,910	4,130			*5,430	3,640	8.34 m
-3.0 m	kg			*9,440	8,520	*7,370	5,650					*4,500	4,250	7.55 m

SK260NLC		Straight boom		Arm: 3.66 m		Bucket: without		Counterweight: 5,580 kg		Shoe: 600 mm (Heavy Lift)				
B	A	3.0 m		4.5 m		6.0 m		7.5 m		9.0 m		At max. reach		
														Radius
10.5 m	kg											*6,200	*6,200	4.23 m
9.0 m	kg			*6,450	*6,450	*5,910	*5,910					*4,450	*4,450	6.49 m
7.5 m	kg			*5,520	*5,520	*6,010	*6,010	*5,220	4,750			*3,820	*3,820	7.85 m
6.0 m	kg			*5,170	*5,170	*5,960	*5,960	*6,070	4,750			*3,520	*3,520	8.74 m
4.5 m	kg	*4,930	*4,930	*6,220	*6,220	*6,760	6,600	*6,720	4,620	*5,040	3,380	*3,380	3,160	9.31 m
3.0 m	kg			*11,880	9,560	*9,080	6,210	7,250	4,420	5,430	3,310	*3,350	2,950	9.62 m
1.5 m	kg			*13,290	8,780	*9,760	5,830	7,030	4,220	5,340	3,220	*3,430	2,880	9.68 m
G.L.	kg			*13,550	8,340	9,610	5,560	6,870	4,080	5,270	3,160	*3,620	2,940	9.50 m
-1.5 m	kg	*7,940	*7,940	*12,650	8,210	9,470	5,440	6,790	4,010	*4,920	3,170	*3,960	3,150	9.08 m
-3.0 m	kg			*10,690	8,290	*8,200	5,470	*6,060	4,060			*4,300	3,580	8.36 m

Notes:

- Do not attempt to lift or hold any load that is greater than these lift capacities at their specified lift point radius and heights. Weight of all accessories must be deducted from the above lift capacities.
- Lift capacities are based on machine standing on level, firm, and uniform ground. User must make allowance for job conditions such as soft or uneven ground, out of level conditions, side loads, sudden stopping of loads, hazardous conditions, experience of personnel, etc.
- Arm top defined as lift point.
- The above lift capacities are in compliance with ISO 10567. They do not exceed 87% of hydraulic lift capacity or 75% of tipping load. Lift capacities marked with an asterisk(*) are limited by hydraulic capacity rather than tipping load.
- Operator should be fully acquainted with the Operator's and Maintenance Instructions before operating this machine. Rules for safe operation of equipment should be adhered to at all times.
- Lift capacities apply to only machine as originally manufactured and normally equipped by KOBELCO CONSTRUCTION MACHINERY CO., LTD.

Specifications



Engine

Model	ISUZU 6HK1
Type	Four-cycle, water-cooled, direct injection diesel engine, turbo charged, EU Stage V exhaust emission regulation
No. of cylinders	6
Bore and stroke	115 mm × 125 mm
Displacement	7.790 L
Rated power output	198 kW /1,900 min ⁻¹ (ISO 9249: with fan)
	210 kW /1,900 min ⁻¹ (ISO 14396: without fan)
Max. torque	1,011 N·m /1,500 min ⁻¹ (ISO 9249: with fan)
	1,080 N·m /1,500 min ⁻¹ (ISO 14396: without fan)



Hydraulic System

Pump	
Type	Two variable displacement axial piston pumps + extra gear pump + pilot gear pump
Max. discharge flow	2 × 245 L/min , 1 × 44.3 L/min , 1 × 19 L/min
Relief valve setting	
Boom, arm and bucket	34.3 MPa
Power Boost	37.8 MPa
Travel circuit	34.3 MPa
Swing circuit	29.0 MPa
Control circuit	5.0 MPa
Pilot control pump	Gear type
Main control valve	8 - Spool valve
Oil cooler	Air cooled type



Swing System

Swing motor	One fixed displacement piston motor
Brake	Hydraulic; locking automatically when the swing control lever is in the neutral position
Parking brake	Wet multiple plate
Swing speed	10.2 min ⁻¹
Swing torque	101 kN·m
Maximum swing gradient (Loaded)*	23 % {13°}

*Value for the least favourable specification



Travel System

Travel motors	2 × axial-piston, two-step motors
Travel brakes	Hydraulic brake per motor
Parking brakes	Oil disc brake per motor
Travel shoes	50 each side
Travel speed	5.2/3.1 km/h
Rated drawbar pull	279 kN (SAE J 1309)
Gradeability	70 % {35°}



Cab & Control

Cab

All-weather, sound-suppressed steel cab mounted on the high suspension mounts filled with silicone oil and equipped with a heavy, insulated floor mat.

Control

Two hand levers and two foot pedals for travel

Two hand levers for excavating and swing

Electric rotary-type engine throttle

Noise levels

External	106 dB(A) (2000/14/EC)
Operator	72 dB(A) (ISO 6396: 2008)

Vibration levels

Hand/arm*	≤ 2.5 m/s ²
Body*	≤ 0.5 m/s ²

*For the risk assessment according to 2002/44/EC, refer to ISO/TR 25398: 2006



Cylinders

Boom cylinders	140 mm × 1,305 mm
Arm cylinder	150 mm × 1,675 mm
Bucket cylinder	130 mm × 1,208 mm



Refilling Capacities & Lubrications

Fuel tank	503 L
Cooling system	41.4 L
Engine oil	48.6 L
Travel reduction gear	2 × 7.5 L
Swing reduction gear	1 × 7.4 L
Hydraulic oil tank	245 L tank oil level
	410 L hydraulic system
DEF/Urea tank	83 L

Specifications



Working Ranges

Unit: mm

Range	Arm	Straight boom	
		Standard 3.10 m	Long 4.00 m
a- Max. digging reach		11,060	11,950
b- Max. digging reach at ground level		10,870	11,780
c- Max. digging depth		5,190	6,090
d- Max. digging height		12,520	13,340
d'- Max. working height to arm top		10,950	11,770
e- Max. dumping clearance		9,420	10,240
f- Min. dumping clearance		3,800	2,990
g- Max. vertical wall digging depth		4,520	5,370
h- Min. swing radius		3,020	3,430
i- Horizontal digging stroke at ground level		5,180	6,430
j- Digging depth for 2.4 m (8') flat bottom		5,030	5,960
Bucket capacity ISO heaped m ³		1.20	1.00

Digging Force (ISO 6015)

Unit: kN

Arm length	Standard 3.10 m	Long 4.00 m
Bucket digging force	188 208*	188 208*
Arm crowding force	126 139*	105 115*

*Power Boost engaged

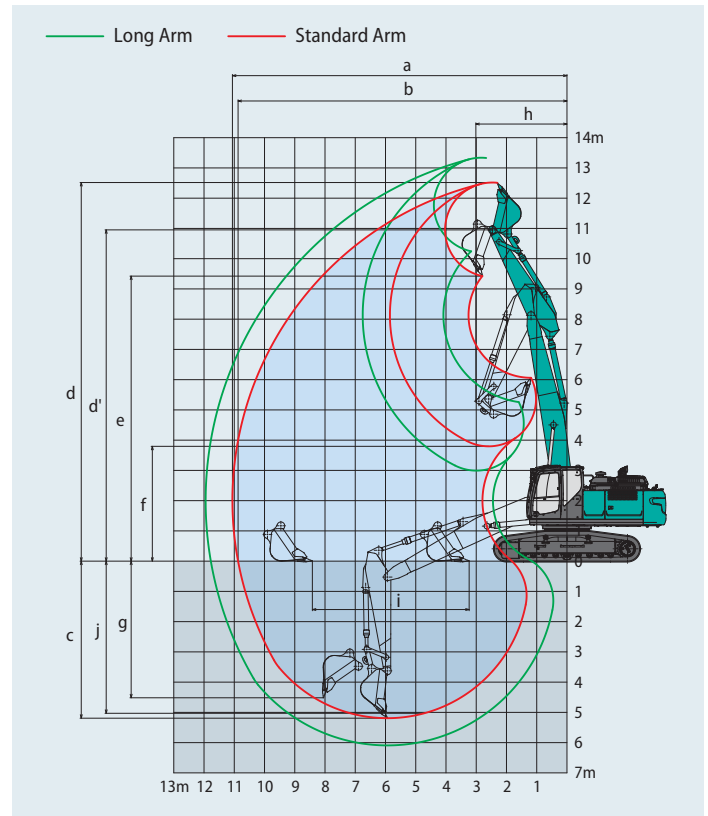

Dimensions

Arm length		Standard 3.10 m	Long 4.00 m
A Overall length		10,800	10,740 (10,850**)
B Overall height (to top of boom)		3,070	3,990 (3,310**)
C Overall width of crawler	SK300LC	3,190	
	SK300NLC	2,990	
D Overall height (to top of cab)		3,210	
E Ground clearance of rear end*		1,200	
F Ground clearance*		490	

Unit: mm

G Tail swing radius		3,300
G' Distance from centre of swing to rear end		3,270
H Tumbler distance		4,000
I Overall length of crawler		4,870
J Track gauge	SK300LC	2,590
	SK300NLC	2,390
K Shoe width		600
L Overall width of upperstructure		2,980

*Without including height of shoe lug ** Without bucket

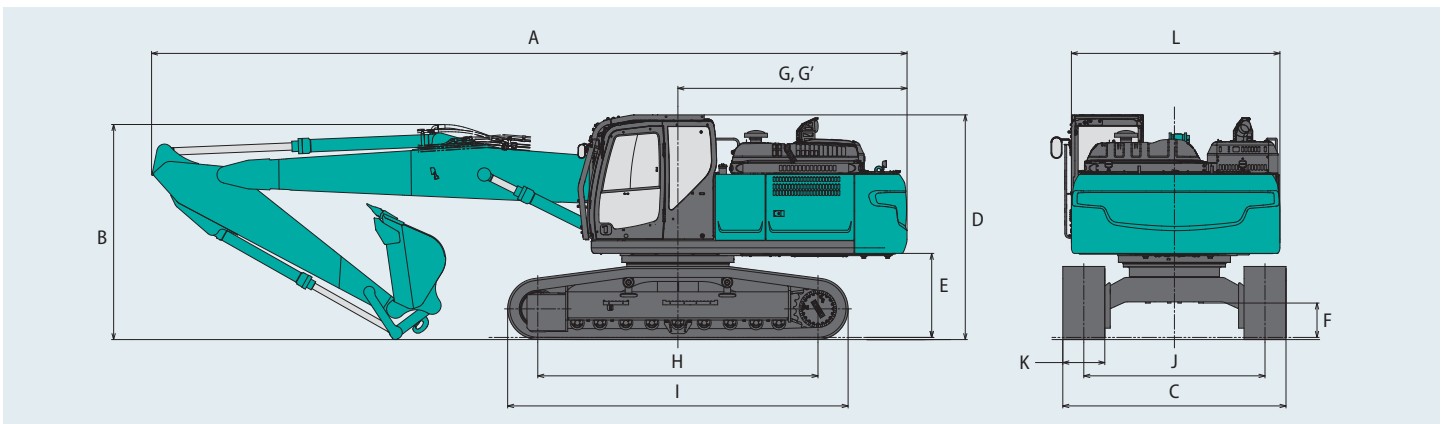

Operating Weight & Ground Pressure

In standard trim, with Straight boom, 3.10 m arm, and 1.20 m³ ISO heaped bucket.

Shaped			Triple grouser shoes (even height)				Double grouser shoes
Shoe width	mm		600	700	800	900	600
Overall width of crawler	SK300LC	mm	3,190	3,290	3,390	3,490	3,190
	SK300NLC	mm	2,990	3,090	—	—	2,990
Ground pressure	SK300LC	kPa	60	52	46	42	60
	SK300NLC	kPa	60	52	—	—	60
Operating weight	SK300LC	kg	31,500	32,200	32,600	33,000	31,700
	SK300NLC	kg	31,500	32,100	—	—	31,600

Lift Capacities

SK300^{LC} **SK300^{NLC}**
SK300LC-11E SK300NLC-11E

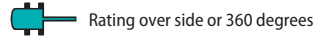
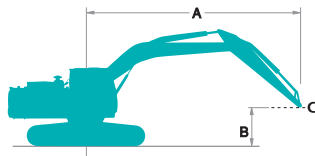

A - Reach from swing centerline to arm top
B - Arm top height above/below ground
C - Lift point
Relief valve setting: 37.8 MPa

SK300LC		Straight boom		Arm: 3.10 m		Bucket: without		Counterweight: 5,540 kg		Shoe: 600 mm (Heavy Lift)				
B	A	4.5 m		6.0 m		7.5 m		9.0 m		At max. reach		Radius		
10.5 m	kg											*7,820	*7,820	3.91 m
9.0 m	kg	*8,950	*8,950	*7,420	*7,420							*5,380	*5,380	6.30 m
7.5 m	kg	*8,030	*8,030	*8,550	*8,550	*6,330	6,060					*4,580	*4,580	7.69 m
6.0 m	kg	*8,220	*8,220	*9,000	8,660	*8,320	6,060					*4,200	*4,200	8.59 m
4.5 m	kg	*12,950	12,920	*10,180	8,290	*8,640	5,900	*5,880	4,410			*4,030	*4,030	9.15 m
3.0 m	kg	*15,210	11,890	*11,180	7,850	8,980	5,680	6,800	4,330			*4,010	*4,010	9.44 m
1.5 m	kg	*14,780	11,170	*11,880	7,470	8,760	5,480	6,710	4,250			*4,100	3,950	9.48 m
G.L.	kg	*14,730	10,920	*11,900	7,250	8,610	5,360	6,670	4,210			*4,340	4,070	9.27 m
-1.5 m	kg	*14,420	10,940	*11,100	7,200	8,590	5,330					*4,780	4,400	8.79 m
-3.0 m	kg	*11,760	11,130	*9,260	7,300	*6,720	5,450					*5,280	5,080	8.00 m

SK300LC		Straight boom		Arm: 4.00 m		Bucket: without		Counterweight: 5,540 kg		Shoe: 600 mm (Heavy Lift)						
B	A	3.0 m		4.5 m		6.0 m		7.5 m		9.0 m		At max. reach				
														Radius		
10.5 m	kg													5.78 m		
9.0 m	kg			*7,400	*7,400			*6,560	*6,560	*4,330	*4,330			*4,670	*4,670	7.59 m
7.5 m	kg							*6,240	*6,240	*6,250	6,240			*3,230	*3,230	8.77 m
6.0 m	kg							*6,290	*6,290	*6,620	6,150	*5,540	4,480	*2,990	*2,990	9.56 m
4.5 m	kg															10.07 m
3.0 m	kg															10.33 m
1.5 m	kg															10.36 m
G.L.	kg															10.17 m
-1.5 m	kg	*8,050	*8,050	*15,320	10,580	*11,410	6,960	8,370	5,120	6,470	4,010			*3,330	*3,330	9.74 m
-3.0 m	kg	*12,700	*12,700	*13,400	10,660	*10,230	6,970	*7,840	5,140	*4,460	4,120			*3,780	*3,780	9.04 m

SK300NLC		Straight boom		Arm: 3.10 m		Bucket: without		Counterweight: 5,540 kg		Shoe: 600 mm (Heavy Lift)				
B	A	4.5 m		6.0 m		7.5 m		9.0 m		At max. reach		Radius		
10.5 m	kg													3.91 m
9.0 m	kg	*8,950	*8,950	*7,420	*7,420									6.30 m
7.5 m	kg	*8,030	*8,030	*8,550	8,150	*6,330	5,570							7.69 m
6.0 m	kg	*8,220	*8,220	*9,000	7,970	*8,320	5,570							8.59 m
4.5 m	kg	*12,950	11,760	*10,180	7,600	*8,640	5,410	*5,880	4,030					9.15 m
3.0 m	kg	*15,210	10,770	*11,180	7,160	8,930	5,200	6,760	3,960					9.44 m
1.5 m	kg	*14,780	10,070	*11,880	6,790	8,710	5,010	6,670	3,880					9.48 m
G.L.	kg	*14,730	9,820	*11,900	6,580	8,570	4,880	6,630	3,840					9.27 m
-1.5 m	kg	*14,420	9,840	*11,100	6,530	8,540	4,860							8.79 m
-3.0 m	kg	*11,760	10,030	*9,260	6,630	*6,720	4,970							8.00 m

SK300NLC		Straight boom		Arm: 4.00 m		Bucket: without		Counterweight: 5,540 kg		Shoe: 600 mm (Heavy Lift)				
B	A	3.0 m		4.5 m		6.0 m		7.5 m		9.0 m		At max. reach		
														Radius
10.5 m	kg													5.78 m
9.0 m	kg													7.59 m
7.5 m	kg													8.77 m
6.0 m	kg													9.56 m
4.5 m	kg													10.07 m
3.0 m	kg													10.33 m
1.5 m	kg													10.36 m
G.L.	kg													10.17 m
-1.5 m	kg	*8,050	*8,050	*15,320	9,490	*11,410	6,290	8,320	4,640	6,430	3,640			9.74 m
-3.0 m	kg	*12,700	*12,700	*13,400	9,570	*10,230	6,310	*7,840	4,660	*4,460	3,750			9.04 m

Notes:

- Do not attempt to lift or hold any load that is greater than these lift capacities at their specified lift point radius and heights. Weight of all accessories must be deducted from the above lift capacities.
- Lift capacities are based on machine standing on level, firm, and uniform ground. User must make allowance for job conditions such as soft or uneven ground, out of level conditions, side loads, sudden stopping of loads, hazardous conditions, experience of personnel, etc.
- Arm top defined as lift point.
- The above lift capacities are in compliance with ISO 10567. They do not exceed 87% of hydraulic lift

capacity or 75% of tipping load. Lift capacities marked with an asterisk(*) are limited by hydraulic capacity rather than tipping load.

- Operator should be fully acquainted with the Operator's and Maintenance Instructions before operating this machine. Rules for safe operation of equipment should be adhered to at all times.
- Lift capacities apply to only machine as originally manufactured and normally equipped by KOBELCO CONSTRUCTION MACHINERY CO., LTD.

Specifications



Engine

Model	ISUZU 6HK1
Type	Four-cycle, water-cooled, direct injection diesel engine, turbo charged, EU Stage V exhaust emission regulation
No. of cylinders	6
Bore and stroke	115 mm x 125 mm
Displacement	7.790 L
Rated power output	198 kW/1,900 min ⁻¹ (ISO 9249 : with fan)
	210 kW/1,900 min ⁻¹ (ISO 14396: without fan)
Max. torque	1,011 N-m/1,500 min ⁻¹ (ISO 9249 : with fan)
	1,080 N-m/1,500 min ⁻¹ (ISO 14396: without fan)



Hydraulic System

Pump	
Type	Two variable displacement axial piston pumps + extra gear pump + pilot gear pump
Max. discharge flow	2 x 294 L/min, 1 x 44.3 L/min, 1 x 19 L/min
Relief valve setting	
Boom, arm and bucket	34.3 MPa
Power Boost	37.8 MPa
Travel circuit	35.8 MPa
Swing circuit	29.5 MPa
Control circuit	5.0 MPa
Pilot control pump	Gear type
Main control valve	8-spool valve
Oil cooler	Air cooled type



Swing System

Swing motor	One fixed displacement piston motor
Brake	Hydraulic; locking automatically when the swing control lever is in the neutral position
Parking brake	Wet multiple plate
Swing speed	10.0 min ⁻¹
Swing torque	120 kN-m
Maximum swing gradient (Loaded)*	30 % {17 °}

*Value for the least favourable specification



Travel System

Travel motors	2 × axial-piston, two-step motors
Travel brakes	Hydraulic brake per motor
Parking brakes	Oil disc brake per motor
Travel shoes	48 each side
Travel speed	5.6/3.3 km/h
Rated drawbar pull	321 kN (SAE J 1309)
Gradeability	70 % {35°}



Cab & Control

Cab

All-weather, sound-suppressed steel cab mounted on the high suspension mounts filled with silicone oil and equipped with a heavy, insulated floor mat.

Control

Two hand levers and two foot pedals for travel

Two hand levers for excavating and swing

Electric rotary-type engine throttle

Noise levels

External 106 dB(A) (2000/14/EC)

Operator 73 dB(A) (ISO 6396)

Vibration levels

Hand/arm* ≤ 2.5 m/s²

Body* ≤ 0.5 m/s²

*For the risk assessment according to 2002/44/EC, refer to ISO/TR 25398: 2006



Cylinders

Boom cylinders	140 mm x 1,550 mm
Arm cylinder	170 mm x 1,788 mm
Bucket cylinder	150 mm x 1,193 mm



Refilling Capacities & Lubrications

Fuel tank	503 L
Cooling system	41.4 L
Engine oil	48.6 L
Travel reduction gear	2 x 8.0 L
Swing reduction gear	1 x 7.4 L
Hydraulic oil tank	245 L tank oil level
	410 L hydraulic system
DEF/Urea tank	83 L



Working Ranges

Unit: mm

Range	Arm	Straight boom	
		Standard 3.30 m	Long 4.15 m
a- Max. digging reach		11,490	12,270
b- Max. digging reach at ground level		11,300	12,090
c- Max. digging depth		5,620	6,470
d- Max. digging height		13,010	13,630
d'- Max. working height to arm top		11,320	11,940
e- Max. dumping clearance		9,680	10,280
f- Min. dumping clearance		3,780	2,970
g- Max. vertical wall digging depth		4,850	5,670
h- Min. swing radius		3,180	3,440
i- Horizontal digging stroke at ground level		5,420	6,630
j- Digging depth for 2.4 m (8') flat bottom		5,470	6,340
Bucket capacity ISO heaped m ³		1.40	1.20

Digging Force (ISO 6015)

Unit: kN

Arm length	Standard 3.30 m	Long 4.15 m
Bucket digging force	222 244*	220 242*
Arm crowding force	163 180*	140 154*

*Power Boost engaged

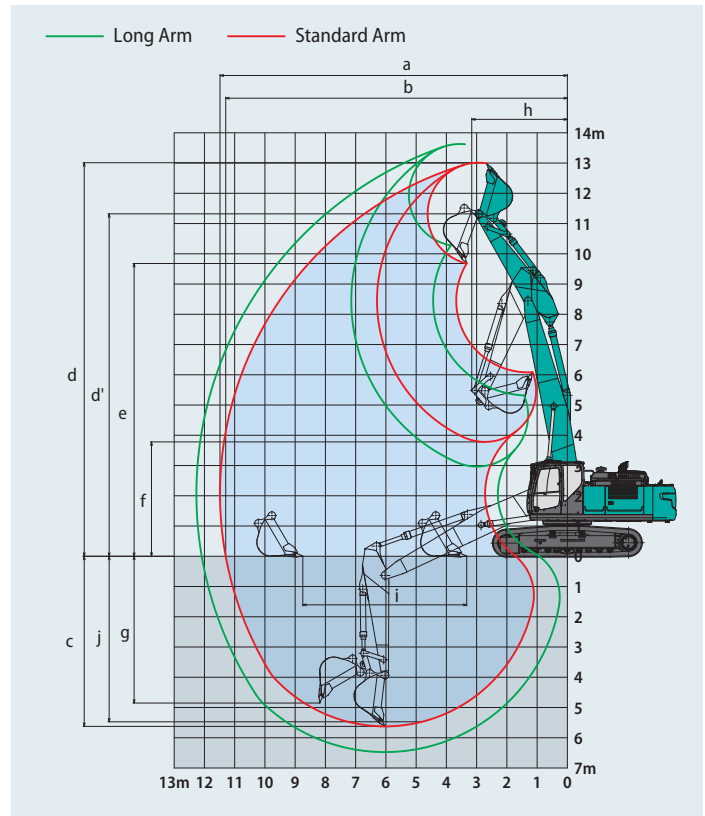

Dimensions

Arm length		Standard 3.30 m	Long 4.15 m
A Overall length		11,310	11,240 (11,330**)
B Overall height (to top of boom)		3,260	4,070 (3,390**)
C Overall width of crawler	SK350LC	3,190	
	SK350NLC	2,990	
D Overall height (to top of cab)		3,200	
E Ground clearance of rear end*		1,190	
F Ground clearance*		485	

Unit: mm

G Tail swing radius		3,600
G' Distance from centre of swing to rear end		3,600
H Tumbler distance		4,050
I Overall length of crawler		4,960
J Track gauge	SK350LC	2,590
	SK350NLC	2,390
K Shoe width		600
L Overall width of upperstructure		2,980

*Without including height of shoe lug ** Without bucket

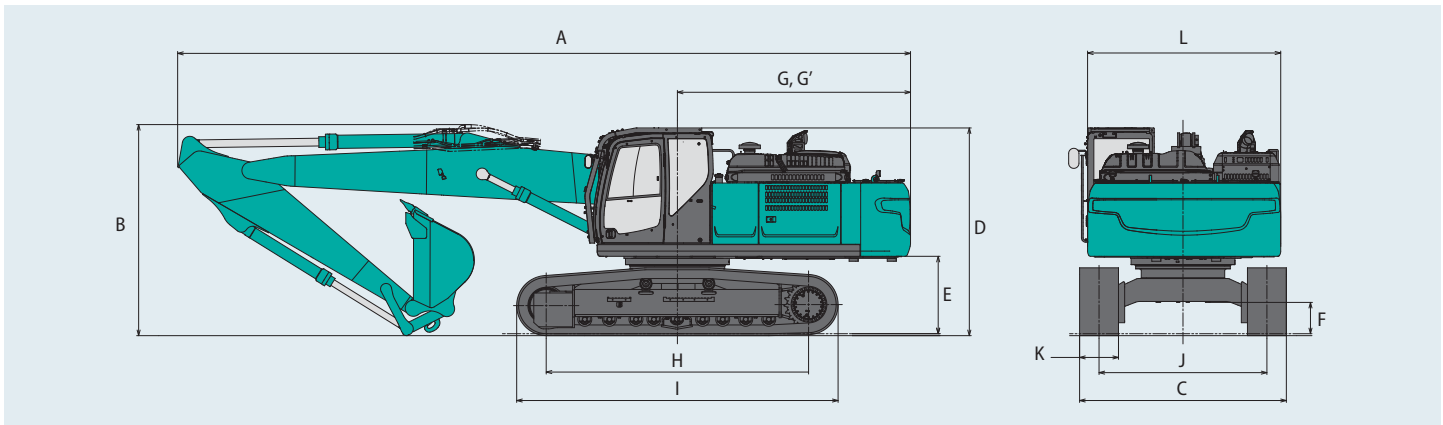

Operating Weight & Ground Pressure

In standard trim, with Straight boom, 3.30 m arm, and 1.40 m³ ISO heaped bucket.

Shaped		Triple grouser shoes (even height)				Double grouser shoes	
Shoe width	mm	600	700	800	900	600	
Overall width of crawler	SK350LC	mm	3,190	3,290	3,390	3,490	3,190
	SK350NLC	mm	2,990	3,090	—	—	2,990
Ground pressure	SK350LC	kPa	70	61	54	48	71
	SK350NLC	kPa	69	61	—	—	70
Operating weight	SK350LC	kg	37,200	38,000	38,400	38,800	37,700
	SK350NLC	kg	37,100	37,900	—	—	37,600

Lift Capacities

SK350^{LC} **SK350^{NLC}**
SK350LC-11E SK350NLC-11E

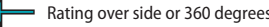
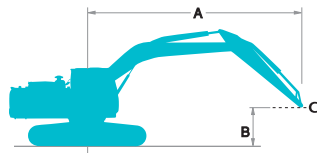

A - Reach from swing centreline to arm top
B - Arm top height above/below ground
C - Lift point
Relief valve setting: 37.8 MPa

SK350LC		Straight boom Arm: 3.30 m Bucket: without Counterweight: 8,590 kg Shoe: 600 mm (Heavy Lift)												
B	A	3.0 m		4.5 m		6.0 m		7.5 m		9.0 m		At max. reach		Radius
10.5 m	kg			*11,120	*11,120							*8,800	*8,800	4.90 m
9.0 m	kg					*10,720	*10,720					*6,890	*6,890	6.89 m
7.5 m	kg			*10,300	*10,300	*10,890	*10,890	*9,770	8,020			*6,110	*6,110	8.14 m
6.0 m	kg			*11,080	*11,080	*11,370	11,280	*9,840	7,920			*5,740	*5,740	8.97 m
4.5 m	kg			*15,790	*15,790	*12,230	10,760	*10,170	7,680	*8,770	5,770	*5,590	5,270	9.49 m
3.0 m	kg			*17,760	15,360	*13,110	10,160	*10,530	7,380	8,660	5,640	*5,610	4,980	9.75 m
1.5 m	kg			*18,380	14,430	*13,540	9,660	*10,670	7,100	8,520	5,510	*5,790	4,910	9.77 m
G.L.	kg			*17,290	14,090	*13,180	9,370	*10,330	6,930	*8,070	5,430	*6,150	5,040	9.56 m
-1.5 m	kg	*11,530	*11,530	*15,000	14,100	*11,900	9,290	*9,290	6,880	*6,500	5,480	*6,150	5,420	9.10 m
-3.0 m	kg			*11,580	*11,580	*9,500	9,400	*7,080	6,980			*4,890	*4,890	8.34 m

SK350LC		Straight boom Arm: 4.15 m Bucket: without Counterweight: 8,590 kg Shoe: 600 mm (Heavy Lift)														
B	A	3.0 m		4.5 m		6.0 m		7.5 m		9.0 m		10.5 m		At max. reach		Radius
10.5 m	kg					*7,540	*7,540							*6,020	*6,020	6.33 m
9.0 m	kg					*8,640	*8,640	*7,200	*7,200					*5,080	*5,080	7.96 m
7.5 m	kg					*8,430	*8,430	*8,460	8,180	*5,160	*5,160			*4,630	*4,630	9.06 m
6.0 m	kg					*8,830	*8,830	*9,050	8,030	*7,890	5,890			*4,400	*4,400	9.81 m
4.5 m	kg			*10,880	*10,880	*10,920	*10,920	*9,490	7,730	*8,280	5,760			*4,320	*4,320	10.29 m
3.0 m	kg			*16,410	15,840	*12,300	10,290	*9,990	7,370	*8,450	5,570	*4,740	4,340	*4,360	4,310	10.53 m
1.5 m	kg			*17,880	14,580	*13,070	9,660	*10,340	7,030	8,410	5,390	*5,160	4,280	*4,500	4,240	10.55 m
G.L.	kg			*17,800	13,910	*13,180	9,230	*10,310	6,770	8,260	5,250			*4,780	4,320	10.36 m
-1.5 m	kg	*11,640	*11,640	*16,320	13,700	*12,430	9,020	*9,710	6,640	*7,520	5,190			*5,250	4,590	9.93 m
-3.0 m	kg	*16,850	*16,850	*13,620	*13,620	*10,700	9,030	*8,270	6,650	*5,680	5,280			*4,970	*4,970	9.25 m
-4.5 m	kg					*7,690	*7,690							*3,530	*3,530	8.23 m

SK350NLC		Straight boom Arm: 3.30 m Bucket: without Counterweight: 8,590 kg Shoe: 600 mm (Heavy Lift)												
B	A	3.0 m		4.5 m		6.0 m		7.5 m		9.0 m		At max. reach		Radius
10.5 m	kg			*11,120	*11,120							*8,800	*8,800	4.90 m
9.0 m	kg					*10,720	*10,720					*6,890	*6,890	6.89 m
7.5 m	kg			*10,300	*10,300	*10,890	10,750	*9,770	7,440			*6,110	*6,110	8.14 m
6.0 m	kg			*11,080	*11,080	*11,370	10,450	*9,840	7,340			*5,740	5,400	8.97 m
4.5 m	kg			*15,790	15,320	*12,230	9,930	*10,170	7,100	8,750	5,330	*5,590	4,860	9.49 m
3.0 m	kg			*17,760	14,000	*13,110	9,340	*10,530	6,800	8,610	5,200	*5,610	4,590	9.75 m
1.5 m	kg			*18,380	13,110	*13,540	8,850	*10,670	6,540	8,470	5,070	*5,790	4,520	9.77 m
G.L.	kg			*17,290	12,780	*13,180	8,570	*10,330	6,360	*8,070	5,000	*6,150	4,640	9.56 m
-1.5 m	kg	*11,530	*11,530	*15,000	12,790	*11,900	8,490	*9,290	6,310	*6,500	5,040	*6,150	4,990	9.10 m
-3.0 m	kg			*11,580	*11,580	*9,500	8,600	*7,080	6,420			*4,890	*4,890	8.34 m

SK350NLC		Straight boom Arm: 4.15 m Bucket: without Counterweight: 8,590 kg Shoe: 600 mm (Heavy Lift)														
B	A	3.0 m		4.5 m		6.0 m		7.5 m		9.0 m		10.5 m		At max. reach		Radius
10.5 m	kg					*7,540	*7,540							*6,020	*6,020	6.33 m
9.0 m	kg					*8,640	*8,640	*7,200	*7,200					*5,080	*5,080	7.96 m
7.5 m	kg					*8,430	*8,430	*8,460	7,600	*5,160	*5,160			*4,630	*4,630	9.06 m
6.0 m	kg					*8,830	*8,830	*9,050	7,440	*7,890	5,450			*4,400	*4,400	9.81 m
4.5 m	kg			*10,880	*10,880	*10,920	10,140	*9,490	7,150	*8,280	5,320			*4,320	4,190	10.29 m
3.0 m	kg			*16,410	14,470	*12,300	9,470	*9,990	6,800	*8,450	5,130	*4,740	3,980	*4,360	3,960	10.53 m
1.5 m	kg			*17,880	13,250	*13,070	8,850	*10,340	6,460	8,360	4,950	*5,160	3,920	*4,500	3,890	10.55 m
G.L.	kg			*17,800	12,590	*13,180	8,430	*10,310	6,200	8,210	4,810			*4,780	3,960	10.36 m
-1.5 m	kg	*11,640	*11,640	*16,320	12,390	*12,430	8,230	*9,710	6,070	*7,520	4,760			*5,250	4,210	9.93 m
-3.0 m	kg	*16,850	*16,850	*13,620	12,480	*10,700	8,230	*8,270	6,080	*5,680	4,840			*4,970	4,710	9.25 m
-4.5 m	kg					*7,690	*7,690							*3,530	*3,530	8.23 m

Notes:

- Do not attempt to lift or hold any load that is greater than these lift capacities at their specified lift point radius and heights. Weight of all accessories must be deducted from the above lift capacities.
- Lift capacities are based on machine standing on level, firm, and uniform ground. User must make allowance for job conditions such as soft or uneven ground, out of level conditions, side loads, sudden stopping of loads, hazardous conditions, experience of personnel, etc.
- Arm top defined as lift point.
- The above lift capacities are in compliance with ISO 10567. They do not exceed 87% of hydraulic lift capacity or 75% of tipping load. Lift capacities marked with an asterisk(*) are limited by hydraulic capacity rather than tipping load.
- Operator should be fully acquainted with the Operator's and Maintenance Instructions before operating this machine. Rules for safe operation of equipment should be adhered to at all times.
- Lift capacities apply to only machine as originally manufactured and normally equipped by KOBELCO CONSTRUCTION MACHINERY CO., LTD.

Standard and Optional Equipment

● = Std ○ = Opt — = N/A

Category	Description	SK260LC/NLC-11E		SK300LC/NLC-11E		SK350LC/NLC-11E	
		LC	NLC	LC	NLC	LC	NLC
ENGINE	YANMAR 4TN107FTT (EU Stage V compliant)	●	●	—	—	—	—
	ISUZU 6HK1 (EU Stage V compliant)	—	—	●	●	●	●
	Exhaust DOC DPF SCR system	●	●	●	●	●	●
	Alternator 24 V / 80 A	●	●	—	—	—	—
	Alternator 24 V / 90 A	—	—	●	●	●	●
	Starter motor 24 V / 5 kW	●	●	●	●	●	●
	Batteries 2 x 12 V (130 Ah)	●	●	—	—	—	—
	Batteries 2 x 12 V (140 Ah)	—	—	●	●	●	●
	Fan suction type cooling system	●	●	●	●	●	●
	Auto deceleration function	●	●	●	●	●	●
	Auto Idle Stop (AIS)	●	●	●	●	●	●
	HYDRAULIC SYSTEM	3 work modes H,S,Eco	●	●	●	●	●
Power Boost (37.8 MPa)		●	●	●	●	●	●
Heavy lift mode		●	●	●	●	●	●
Pressure release function		●	●	●	●	●	●
Independent travel function		●	●	●	●	●	●
Auto warm up system		●	●	●	●	●	●
Proportional Hand Control (for R & N&B piping)		●	●	●	●	●	●
Hydraulic oil VG32		●	●	●	●	●	●
PIPING	Hydraulic oil VG46	○	○	○	○	○	○
	Hydraulic oil VG68	○	○	○	○	○	○
	R & N&B piping	●	●	●	●	●	●
CABIN	QH piping	●	●	●	●	●	●
	Air suspension seat with heating	●	●	●	●	●	●
CABIN	10-inch colour monitor	●	●	●	●	●	●
	LED door light	●	●	●	●	●	●
	Air-conditioner	●	●	●	●	●	●
	DAB+ radio (FM/AM & AUX & USB & Bluetooth* & hands free telephone)	●	●	●	●	●	●
	Harness for CAB four lights and CAB yellow flasher	●	●	●	●	●	●
	Parallel wiper	●	●	●	●	●	●
	12 V power outlet	●	●	●	●	●	●
	Rain visor	●	●	●	●	●	●
	Sun screen	●	●	●	●	●	●
	Large footrest	●	●	●	●	●	●
LIGHTS	LED work lights ; 2 on Boom, 2 on Cab top front, 1 on upper frame, 2 on rear counterweight	●	●	●	●	●	●
WORKING EQUIPMENT	Straight boom (6.02 m)	●	●	—	—	—	—
	Straight boom (6.20 m)	—	—	●	●	—	—
	Straight boom (6.50 m)	—	—	—	—	●	●
	Standard HD arm (2.98 m) with rock guard	●	●	—	—	—	—
	Standard HD arm (3.10 m) with rock guard	—	—	●	●	—	—
	Standard HD arm (3.30 m) with rock guard	—	—	—	—	●	●
	Long HD arm (3.66 m) with rock guard	○	○	—	—	—	—
	Long HD arm (4.00 m) with rock guard	—	—	○	○	—	—
	Long HD arm (4.15 m) with rock guard	—	—	—	—	○	○
	Bucket link with lifting hook	●	●	●	●	●	●
COUNTERWEIGHT	Standard C/W (TTL 5,580 kg)	●	●	—	—	—	—
	Semi heavier C/W (TTL 5,540 kg)	—	—	●	●	—	—
	Semi heavier C/W (TTL 8,590 kg)	—	—	—	—	●	●
UNDERCARRIAGE	600 mm steel shoe	●	●	●	●	●	●
	600 mm double grouser shoe	—	—	○	○	○	○
	700 mm steel shoe	○	○	○	○	○	○
	800 mm steel shoe	○	○	○	—	○	—
	900 mm steel shoe	○	—	○	—	○	—
	Track guide (one per side)	●	●	●	●	●	●
	Additional track guides (two additional per side)	●	●	●	●	●	●
	Lower frame guard	●	●	●	●	●	●
SAFETY	Engine emergency stop switch	●	●	●	●	●	●
	Pump emergency mode (KPSS release switch)	●	●	●	●	●	●
	Emergency accel dial	●	●	●	●	●	●
	Emergency manual valve for lowering attachment	●	●	●	●	●	●
	Overload alarm	●	●	●	●	●	●
	Safety valve for boom & arm cylinder	●	●	●	●	●	●
	ROPS compliant cab (ISO 12117-2:2008)	●	●	●	●	●	●
	OPG Level II top guard (ISO 10262:1998)	●	●	●	●	●	●
	OPG Level II front guard (ISO 10262:1998)	●	●	●	●	●	●
	Eagle-eye view camera (Rear, Right, Left)	●	●	●	●	●	●
	Seatbelt indicator on display	●	●	●	●	●	●
	Travel alarm	○	○	○	○	○	○
	Extended handrail	○	○	○	○	○	○
	Emergency escape hammer	●	●	●	●	●	●
OTHERS	Refuelling pump	●	●	●	●	●	●
	Harness for engine room light	●	●	●	●	●	●
	RAL color	○	○	○	○	○	○
	KOMEXS	●	●	●	●	●	●

*The air conditioning system on SK260(N)LC-11E contains fluorinated greenhouse gas HFC-134a (GWP 1430). Quantity of gas 0.8 kg (CO₂ equivalent 1.2 t).

*The air conditioning system on SK300(N)LC-11E/ SK350(N)LC-11E contains fluorinated greenhouse gas HFC-134a (GWP 1430). Quantity of gas 0.9 kg (CO₂ equivalent 1.3 t).

Note: Bluetooth* is a registered trademark of the Bluetooth SIG Inc.

Note: This catalogue may contain attachments and optional equipment that are not available in your area. And it may contain photographs of machines with specifications that differ from those of machines sold in your areas. Please consult your nearest KOBELCO distributor for those items you require.
Specialist equipment is needed to use this machine in demolition work. Before using it please contact your KOBELCO dealer.
Due to our policy of continuous product improvements all designs and specifications are subject to change without advance notice.
Copyright by **KOBELCO CONSTRUCTION MACHINERY CO., LTD.** No part of this catalogue may be reproduced in any manner without notice.

KOBELCO CONSTRUCTION MACHINERY EUROPE B.V.

www.kobelco-europe.com



Enquiries To: