

KOBELCO

Performance  Design

SK380SRLC

- Bucket capacity:
1.20 m³
- Engine power:
210 kW / 1,900 min⁻¹
- Operating weight:
36,800 – 39,400 kg



Complies with the EU Stage V
exhaust emission regulation

Built for Perfectionists™



SK380SR_{LC}



Performance



Design

SK380SRLC of KOBELCO has realised a completely new value by harmonising PERFORMANCE and DESIGN.

Performance enhancements offer greater efficiency and productivity along with increased power and speed. Design improvements provide the ultimate in comfort and control.

KOBELCO refuses to compromise, creating machines that meet every challenge.

THE ULTIMATE IN SIMPLE DESIGN

In our pursuit of functional beauty and styling,
we created an all new interior design focused with the operator in mind.

Jog dial

This dial integrates multiple functions into a single, easy to use interface.
Even with gloves on, the operator can make the adjustments they need.

LED Illumination

Dials and buttons are now backlit to provide a bright, clear view
in any lighting condition.







UNFORGETTABLE COMFORT

Air suspension seat

A GRAMMER* seat is installed as standard equipment, which achieves excellent shock absorption and superior ride comfort.

*GRAMMER is trademark of GRAMMER AG, registered in Germany and other countries.

Multi Vent Air Conditioner

Cool air is blown from multiple outlets toward the operator's body for more comfortable operation.

Ergonomic Lever Angles

Operators can move levers horizontally without twisting their wrists, reducing fatigue.



New hydraulic control

Our newly upgraded hydraulic control system responds to shorter lever strokes than previous models, delivering swifter, more precise movement and improved lever operability.

LED Interior Light

Interior lights turn on and off automatically when the door is open or the ignition is turned to the OFF position. This ensures safe entry and exit in the dark.

Parallel wipers secure a wide field of view



KOBELCO



04:33



SETTING MENU



PICTURE OF CAMERA



CLOCK SETTING



SCREEN BRIGHTNESS



MAINTENANCE



CONSUMPTION



LANGUAGE SELECTION



PRESSURE RELEASE



SAFETY ON FULL DISPLAY

Standard 3 Sides Safety Camera System

Our high-resolution, large display shows right, left and rear side cameras together. Multiple display allows the operator to customize viewing needs to enhance operator awareness and jobsite safety.

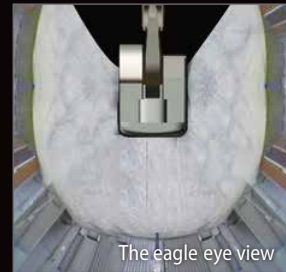
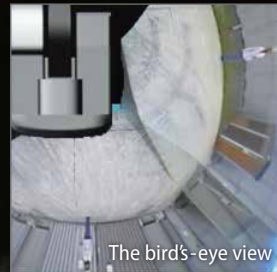
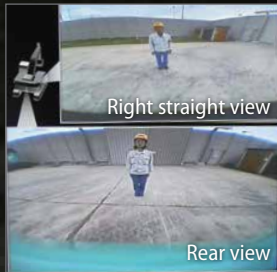

Large 10-Inch Color Monitor

The easy-to-operate menu screen and recognizable icons assist the operator to select the most important information needed to ensure jobsite safety and machine control.



Dial in the Right Information

Simply turn the jog dial to the right or left to select an operational feature, then press the dial to confirm selection.



IDEAL FOR URBAN WORK SITES PROVIDES A BROAD WORKING RANGE

Minimal swing radius improves efficiency

The tail of the upper body extends very little past the crawlers, so the operator can concentrate on the job at hand. This also reduces the risk of collision damage.

Easy workability even in Close Quarters

The compact design allows continuous 180° dig, and load operations within a working space of just 5.35m.



Figures above show the value for standard boom and standard arm spec.

EXPERIENCING A COMPETENT PERFORMANCE

Higher Efficiency, plus a EU Stage V Compliant Engine

The new SK380SRLC is equipped with a Stage V compliant engine, which has a higher torque value. Superior balance between engine output and torque contributes to more efficient performance than the previous models.

In addition, the DPF maintenance interval has been extended.



Model: ISUZU 6HK1

Engine output

210 kW / 1,900 min⁻¹

Power Boost

When you need more power instantly, engage Power Boost to get 10% more power with no time limit.

■ Max. Bucket Digging Force (Arm 3.10 m)

Normal: **189 kN**

With Power Boost: **208 kN**

■ Max. Arm Crowding Force (Arm 3.10 m)

Normal: **126 kN**

With Power Boost: **139 kN**



EXCELLENT LIFTING PERFORMANCE IN NARROW SPACES

Drawbar Pulling Force (SAE)

Excellent drawbar force lets you conquer rough terrain and slopes.

314 kN

Lift Capacity

12,390 kg

(Reach: 6.00 m Boom: 6.20 m Arm: 3.10 m Bucket: Without Shoe: 600 mm <Heavy Lift> At Ground Level)

Heavy Lift

This switch is used when lifting a heavy load and power is required for it. Heavy Lift provides 10% more hydraulic pressure and provide greater lifting power at close radius. This allows for a smooth and steady operation while moving heavy objects.

Independent Travel

Selecting Independent Travel dedicates one hydraulic pump to travel and one to the attachment on a continuous basis, allowing for a smooth and constant movement speed even while swinging or using the boom or attachment. With Independent Travel, safely carrying a large pipe across a job site is a breeze.

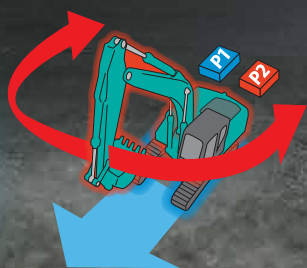



*The picture shows 850mm shoe. 850mm shoe is optional equipment.

GREATER MULTI-FUNCTION CAPABILITIES

Attachment mode selection

The auxiliary flow rates for the bucket, breaker, nibbler, and rotating are all now adjustable by the operator through the monitor, allowing you to change tools quickly and easily. Mode settings for other attachments like the tilt rotator can be added or changed.



CONVENIENT AND SENSIBLE EQUIPMENT



Rear camera

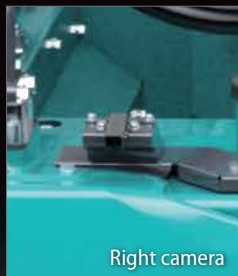

Right camera



Left camera

Standard Rear, Left and Right Side Cameras

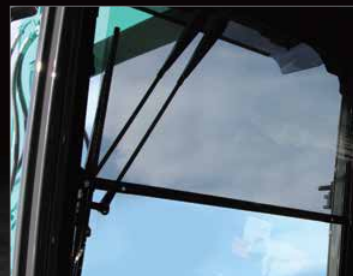

Parallel wiper
Sun screen



Arm



Boom



Bucket link



Counterweight

Machine Guidance Ready Brackets

Pre-welded brackets for quicker and easier installation of Machine Guidance Systems.



Seatbelt Unfastened Indicator On
Monitor



Console mount

The console-integrated seat allows for comfortable operation.



DAB+ radio (FM/AM & AUX & USB & Bluetooth® & hands-free telephone)



USB port/12 V power outlet



Smartphone holder

You can use the holder with your smartphone connected to the USB port.



Engine start password

A password is required when starting the engine for greater security.



Wiper adjustment function

In addition to the intermittent wiper mode and continuous wiper mode, the one-time wiper mode was added.

Note: Bluetooth® is a registered trademark of the Bluetooth SIG Inc.



KOBELCO MONITORING EXCAVATOR SYSTEM

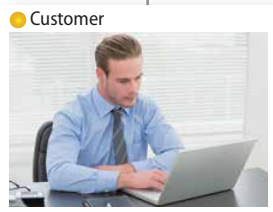

Remote Monitoring for Peace of Mind

KOMEXS (Kobelco Monitoring Excavator System) uses satellite communication and internet to relay data, and therefore can be deployed in areas where other forms of communication are difficult. When a hydraulic excavator is fitted with this system, data on the machine's operation, such as operating hours, location, fuel consumption, and maintenance status can be obtained remotely.

Direct Access to Operational Status

Location Data

Accurate location data can be obtained even from sites where communications are difficult.

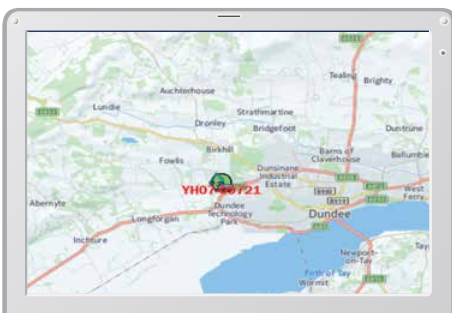

Latest location

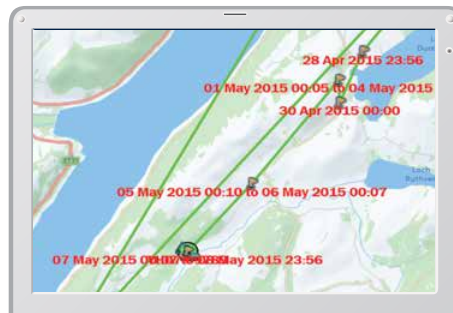

Location records

Period - 11 Apr, 2015		to 10 May, 2015		Search	
Type of Operation	Working Hrs		Ratio		
Total Working Hrs	169 Hrs	100%			
Digging Hrs	72.2 Hrs	43%			
Traveling Hrs	18.3 Hrs	11%			
Idle Hrs	15.9 Hrs	9%			
Opt Att Hrs	62.5 Hrs	37%			
Crane Mode Hrs	0 Hrs	0%			

Work data

Operating Hours

- A comparison of operating times of machines at multiple locations shows which locations are busier and more profitable.
- Operating hours on site can be accurately recorded, for running time calculations needed for rental machines, etc.

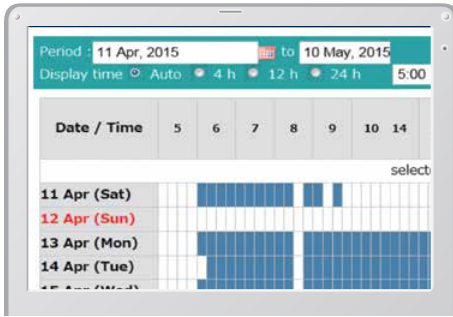

Daily report

Fuel Consumption Data

Data on fuel consumption and idling times can be used to indicate improvements in fuel consumption.

Work mode	Working Hrs	Total Fuel Consumption
H mode	2:06	24.5 L
S mode	0:00	0.0 L
E mode	169:19	1489.7 L
TOTAL	171:25	1514.2 L

Fuel consumption

Graph of Work Content

The graph shows how working hours are divided among different operating categories, including digging, idling, travelling and optional operations.

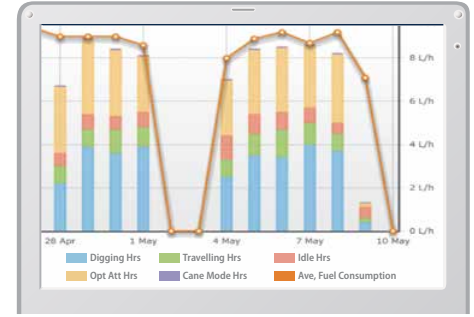

Work status

Maintenance Data and Warning Alerts

Machine Maintenance Data

- Provides maintenance status of separate machines operating at multiple sites.
- Maintenance data is also relayed to KOBELCO service personnel, for more efficient planning of periodic servicing.

Model	Serial No.	Hour Meter	Engine Oil
SK135SRLC-3/SK140SRL	YH07-09721 0.38/0.35	734 Hr	434
SK135SRLC-3/SK140SRL	YH07-09789 0.38/0.35	73 Hr	429
SK210LC-9	YQ13-10454 0.8/0.7	960 Hr	58
SK210LC-9	YQ13-10481 0.8/0.7	549 Hr	498
SK75SR-	YT08-30374		

Maintenance

Warning Alerts

This system warns an alert if an anomaly is sensed, preventing damage that could result in machine downtime.

Alarm Information Can Be Received through E-mail

Alarm information or maintenance notice can be received through E-mail, using a computer or cell phone.



Alarm messages can be received on mobile device.

Daily/Monthly Reports

Operational data downloaded onto a computer helps in formulating daily and monthly reports.

Security System

Engine Start Alarm

The system can be set an alarm if the machine is operated outside designated time.

Setting Condition

Setting Condition Change

Start time 20 : 00

Release time 07 : 00

No Working Whole Day

Mon Tue Wed Thu Fri Sat Sun

Clear

Engine start alarm outside prescribed work time

Area Alarm

It can be set an alarm if the machine is moved out of its designated area to another location.

Setting Condition

Around the current (latest) location 1 Km

Input Latitude and Longitude

Latitude1

Longitude1

Latitude2

Longitude2

Map Clear

Release

Alarm for outside of reset area

EASY MAINTENANCE



Standard Overhead Top Guard Level II

The standard overhead cab guard can be tilted open with gas damper* for easy window cleaning. Meets standard top guard level II requirements. (ISO 10262)



Two-Stage Air Filter



Ground level storage compartment access



DEF/AdBlue[®] Tank

The DEF/AdBlue[®] fill is placed on the step for easy access.

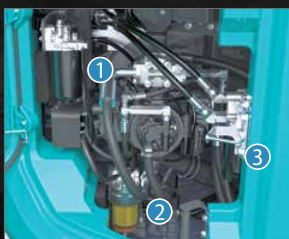

Right Side (Ground Level Maintenance)

Hydraulic pump and engine filter compartment.



Fuel Filter



Pre-Filter with Integrated Water Separator



Engine Oil Filter

Note: AdBlue[®] is a registered trademark of the Verband der Automobilindustrie e.V. (VDA).

*Gas damper is not applicable for 2 piece boom specification.

Specifications

Engine

Model	ISUZU 6HK1
Type	Direct Injection, water-cooled, 4-cycle diesel engine with turbocharger, intercooler complies with EU stage V exhaust emission regulation
No. of cylinders	6
Bore and stroke	115 mm x 125 mm
Displacement	7.790 L
Rated power output	198 kW/1,900 min ⁻¹ (ISO 9249: with fan)
	210 kW/1,900 min ⁻¹ (ISO 14396: without fan)
Max. torque	1,011 N·m/1,500 min ⁻¹ (ISO 9249: with fan)
	1,080 N·m/1,500 min ⁻¹ (ISO 14396: without fan)

Hydraulic system

Pump	
Type	Axial piston pumps + extra gear pump + pilot gear pump
Max. discharge flow	2 x 245 L/min, 1 x 44.3 L/min, 1 x 19 L/min
Relief valve setting	
Boom, arm and bucket	34.3 MPa {350 kgf/cm ² }
Power Boost	37.8 MPa {385 kgf/cm ² }
Travel circuit	34.3 MPa {350 kgf/cm ² }
Swing circuit	29.0 MPa {296 kgf/cm ² }
Control circuit	5.0 MPa {50 kgf/cm ² }
Pilot control pump	Gear type
Main control valves	8-spool
Oil cooler	Air cooled type

Swing system

Swing motor	One fixed displacement piston pump
Parking brake	Wet multiple plate
Swing speed	8.4 min ⁻¹
Swing torque	122.1 kN (SAE)
Maximum swing gradient (loaded)*	32 % {18°}

*Value for the least favourable specification

Attachments

Backhoe bucket and combination

Use	Backhoe bucket		
	Normal digging		
Bucket capacity	ISO heaped	m ³	1.20
Opening width	With side cutter	mm	1,490
	Without side cutter	mm	1,300
No. of teeth			5
Bucket weight		kg	1,060
Combination	3.10 m standard arm		○
	2.40 m short arm		○

○ Recommended

Travel system

Travel motors	2 x axial-piston, two-step motors
Parking brakes	Wet multiple plate
Travel shoes	48 each side
Travel speed	4.6/2.8 km/h
Drawbar pulling force	314 kN (SAE)
Gradeability	70 % {35°}

Cab & control

Cab	
All-weather, sound-suppressed steel cab mounted on the silicon-sealed suspension mounts and equipped with a heavy, insulated floor mat.	
Control	
Two hand levers and two foot pedals for travel	
Two hand levers for excavating and swing	
Electric rotary-type engine throttle	
Noise levels	
External	106 dB(A) (2000/14/EC)
Operator	72 dB(A) (ISO 6396)
Vibration levels	
Hand/arm*	≤ 2.5 m/s ²
Body*	≤ 0.5 m/s ²

*For the risk assessment according to 2002/44/EC, refer to ISO/TR 25398: 2006.

Boom, arm & bucket

Boom cylinders	145 mm x 1,361 mm
Arm cylinder	150 mm x 1,675 mm
Bucket cylinder	130 mm x 1,208 mm
Jib cylinder*	150 mm x 1,230 mm

*For 2 Piece Boom only

Refilling capacities & lubrications

Fuel tank	350 L
Cooling system	41.2 L
Engine oil	48.6 L
Travel reduction gear	2 x 7.5 L
Swing reduction gear	1 x 7.4 L
Hydraulic oil tank	245 L tank oil level
	440 L hydraulic system
DEF/Urea tank	20.7 L

Specifications

Working ranges

Unit: mm

Boom	6.20 m		
Range	Arm	Short 2.40 m	Standard 3.10 m
a- Max. digging reach		10,300	10,930
b- Max. digging reach at ground level		10,090	10,740
c- Max. digging depth		6,290	6,990
d- Max. digging height		10,780	11,170
e- Max. dumping clearance		7,750	8,150
f- Min. dumping clearance		3,870	3,110
g- Max. vertical wall digging depth		5,690	6,110
h- Min. swing radius		3,560	3,450
i- Horizontal digging stroke at ground level		3,990	5,590
j- Digging depth for 2.4 m (8') flat bottom		6,100	6,830
Bucket capacity ISO heaped m ³		1.20	

Digging force (ISO 6015)

Unit: kN

Arm length	Short 2.40 m	Standard 3.10 m
Bucket digging force	189 208*	189 208*
Arm crowding force	158 174*	126 139*

*Power Boost engaged.

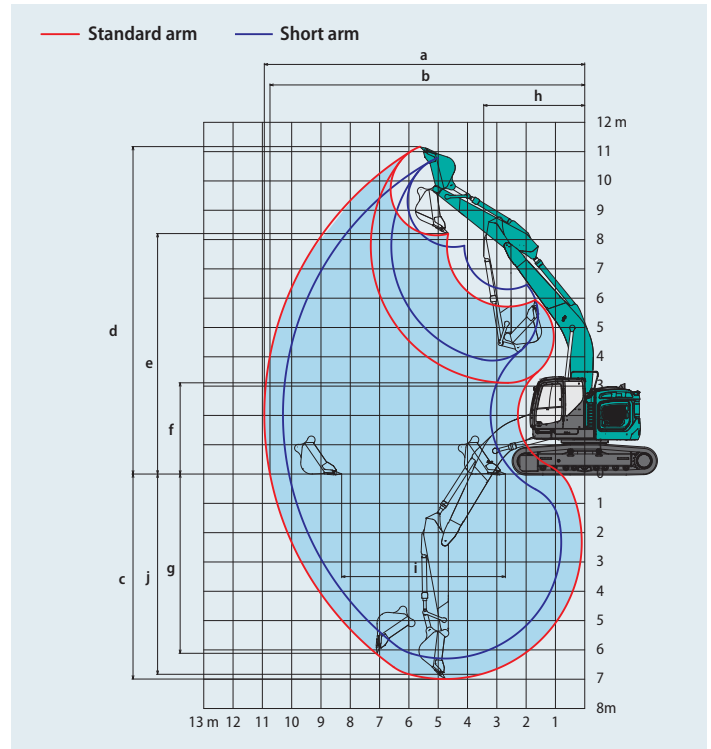

Dimensions

Unit: mm

Arm length	Short 2.40 m	Standard 3.10 m
A Overall length	10,100	9,980
B Overall height (to top of boom)	3,520	3,310
C Overall width	3,190	
D Overall height (to top of handrail)	3,510	
D' Overall height (to top of cab)	3,350	
E Ground clearance of rear end*	1,160	

F Ground clearance*	485
G Tail swing radius	1,900
G' Distance from center of swing to rear end	1,900
H Tumbler distance	4,050
I Overall length of crawler	4,960
J Track gauge	2,590
K Shoe width	600
L Overall width of upperstructure	3,180

*Without including height of shoe lug

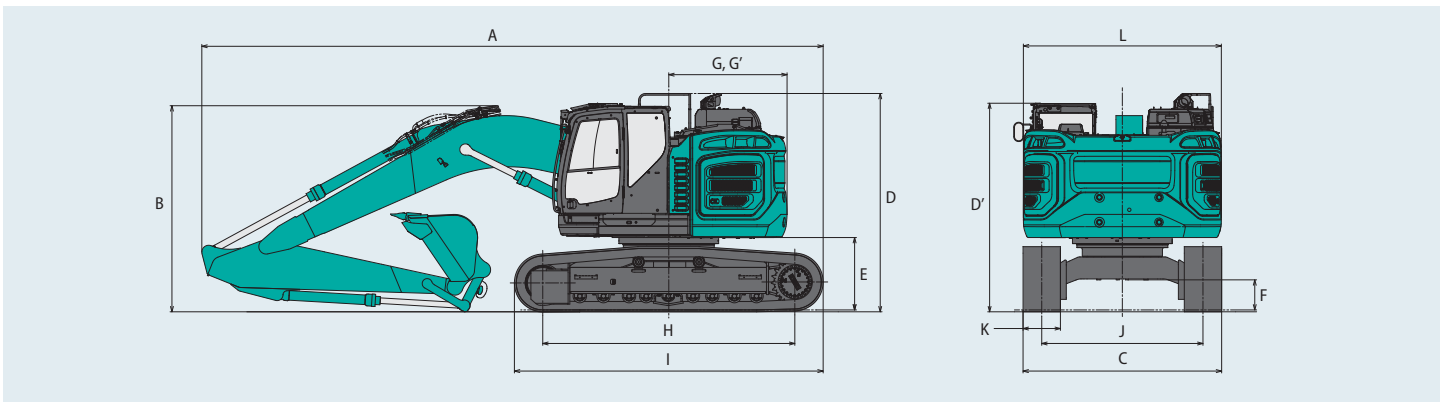

Operating weight & ground pressure

In standard trim, with standard boom, 2.40 m arm, and 1.20 m³ ISO heaped bucket

Type of Grouser	Triple grouser				Double grouser	
Shoes	mm	600	700	800	850	600
Overall width of crawler	mm	3,190	3,290	3,390	3,440	3,190
Ground pressure	kPa	69	60	53	51	70
Operating weight	kg	36,800	37,700	38,100	38,300	37,300

In standard trim, with standard boom, 3.10 m arm, and 1.20 m³ ISO heaped bucket

Type of Grouser	Triple grouser				Double grouser	
Shoes	mm	600	700	800	850	600
Overall width of crawler	mm	3,190	3,290	3,390	3,440	3,190
Ground pressure	kPa	69	61	54	51	70
Operating weight	kg	37,000	37,900	38,300	38,500	37,500

Lift Capacities

SK380SR_{LC}
SK380SR_{LC}-7

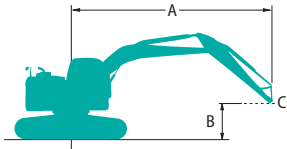

Rating over front



Rating over side or 360 degrees

A - Reach from swing centerline to arm top
B - Arm top height above/below ground
C - Lift point
Relief valve setting: 37.8 MPa {385 kgf/cm²}

SK380SR _{LC}		Boom: 6.20 m Arm: 2.40 m Bucket: without Counterweight: 9,000 kg Shoe: 600 mm (Heavy Lift)										
A \ B		3.0 m		4.5 m		6.0 m		7.5 m		At Max. Reach		Radius
9.0 m	kg									*8,950	*8,950	5.04 m
7.5 m	kg					*8,630	*8,630			*7,680	7,080	6.72 m
6.0 m	kg			*10,240	*10,240	*9,010	8,450	*8,510	5,870	*7,230	5,540	7.74 m
4.5 m	kg			*13,030	12,370	*10,150	8,040	*8,840	5,720	*7,150	4,780	8.36 m
3.0 m	kg					*11,540	7,550	9,330	5,500	*7,340	4,410	8.67 m
1.5 m	kg					*12,610	7,150	9,090	5,280	7,310	4,290	8.71 m
G.L.	kg			*15,460	10,410	12,440	6,940	8,940	5,150	7,530	4,390	8.47 m
-1.5 m	kg	*11,100	*11,100	*16,530	10,460	12,390	6,890	8,920	5,130	8,260	4,790	7.94 m
-3.0 m	kg	*18,730	*18,730	*14,550	10,650	*11,150	7,010			*8,880	5,720	7.03 m
-4.5 m	kg			*10,840	*10,840					*8,260	8,180	5.58 m

SK380SR _{LC}		Boom: 6.20 m Arm: 3.10 m Bucket: without Counterweight: 9,000 kg Shoe: 600 mm (Heavy Lift)												
A \ B		3.0 m		4.5 m		6.0 m		7.5 m		9.0 m		At Max. Reach		Radius
9.0 m	kg					*5,380	*5,380					*4,790	*4,790	6.10 m
7.5 m	kg					*7,420	*7,420	*4,530	*4,530			*4,240	*4,240	7.53 m
6.0 m	kg					*7,960	*7,960	*7,600	5,960			*4,030	*4,030	8.45 m
4.5 m	kg	*16,910	*16,910	*11,300	*11,300	*9,180	8,170	*8,110	5,770	*4,280	4,250	*3,990	*3,990	9.03 m
3.0 m	kg			*14,640	11,590	*10,700	7,640	*8,860	5,500	*6,770	4,140	*4,090	3,910	9.31 m
1.5 m	kg			*17,010	10,690	*12,030	7,180	9,070	5,250	6,910	4,020	*4,330	3,800	9.35 m
G.L.	kg			*17,670	10,320	12,390	6,870	8,860	5,070	*6,450	3,940	*4,770	3,860	9.13 m
-1.5 m	kg	*11,420	*11,420	*17,140	10,250	12,250	6,750	8,770	4,990			*5,530	4,150	8.64 m
-3.0 m	kg	*18,020	*18,020	*15,650	10,370	*11,810	6,790	8,840	5,050			*6,960	4,800	7.82 m
-4.5 m	kg	*17,300	*17,300	*12,830	10,690	*9,480	7,040					*8,160	6,290	6.54 m

Note:

- Do not attempt to lift or hold any load that is greater than these lift capacities at their specified lift point radius and heights. Weight of all accessories must be deducted from the above lift capacities.
- Lift capacities are based on machine standing on level, firm, and uniform ground. User must make allowance for job conditions such as soft or uneven ground, out of level conditions, side loads, sudden stopping of loads, hazardous conditions, experience of personnel, etc.
- Bucket pin attachment point defined as lift point.
- The above lift capacities are in compliance with ISO 10567. They do not exceed 87% of hydraulic lift capacity or 75% of tipping load. Lift capacities marked with an asterisk(*) are limited by hydraulic capacity rather than tipping load.
- Operator should be fully acquainted with the Operator's and Maintenance Instructions before operating this machine. Rules for safe operation of equipment should be adhered to at all times.
- Lift capacities apply to only machine as originally manufactured and normally equipped by KOBELCO CONSTRUCTION MACHINERY CO., LTD.

2 Piece Boom Specifications



Working ranges

Unit: mm

Range	Arm	2 Piece Boom	
		Short 2.40 m	Standard 3.10 m
a- Max. digging reach		10,360	11,010
b- Max. digging reach at ground level		10,160	10,820
c- Max. digging depth		6,170	6,860
d- Max. digging height		11,300	11,770
e- Max. dumping clearance		8,200	8,680
f- Min. dumping clearance		1,060	360
g- Max. vertical wall digging depth		4,300	4,920
h- Min. swing radius		3,410	2,990
i- Horizontal digging stroke at ground level		6,150	7,460
j- Digging depth for 2.4 m (8') flat bottom		6,060	6,760
Bucket capacity ISO heaped m ³		1.20	

Digging force (ISO 6015)

Unit: kN

Arm length	Short 2.40 m	Standard 3.10 m
Bucket digging force	189 208*	189 208*
Arm crowding force	158 174*	126 139*

*Power Boost engaged.

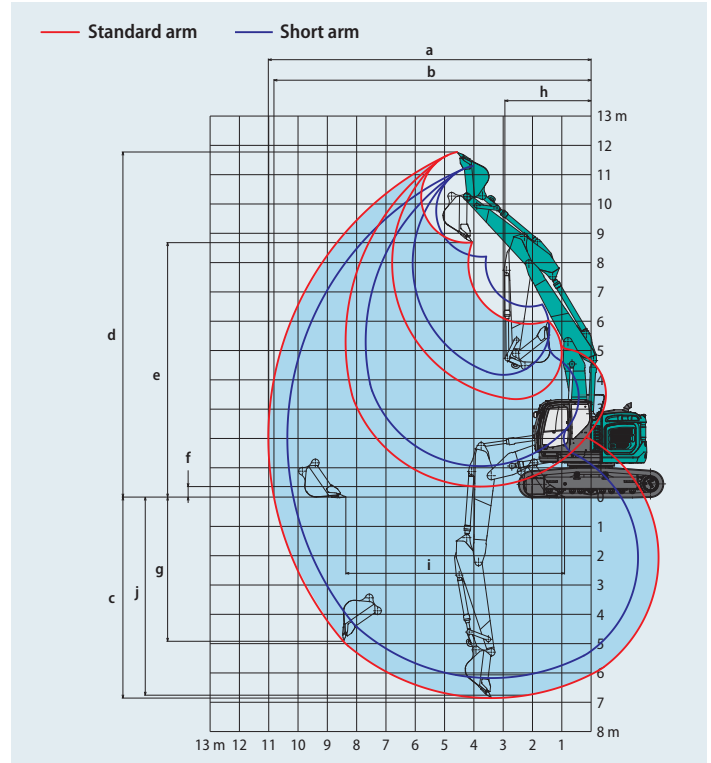

Dimensions

Unit: mm

Arm length	Short 2.40 m	Standard 3.10 m
A Overall length	10,110	10,050
B Overall height (to top of boom)	3,290	3,110
C Overall width	3,190	
D Overall height (to top of handrail)	3,510	
D' Overall height (to top of cab)	3,360	
E Ground clearance of rear end*	1,160	

F Ground clearance*	485
G Tail swing radius	1,900
G' Distance from center of swing to rear end	1,900
H Tumbler distance	4,050
I Overall length of crawler	4,960
J Track gauge	2,590
K Shoe width	600
L Overall width of upperstructure	3,180

*Without including height of shoe lug

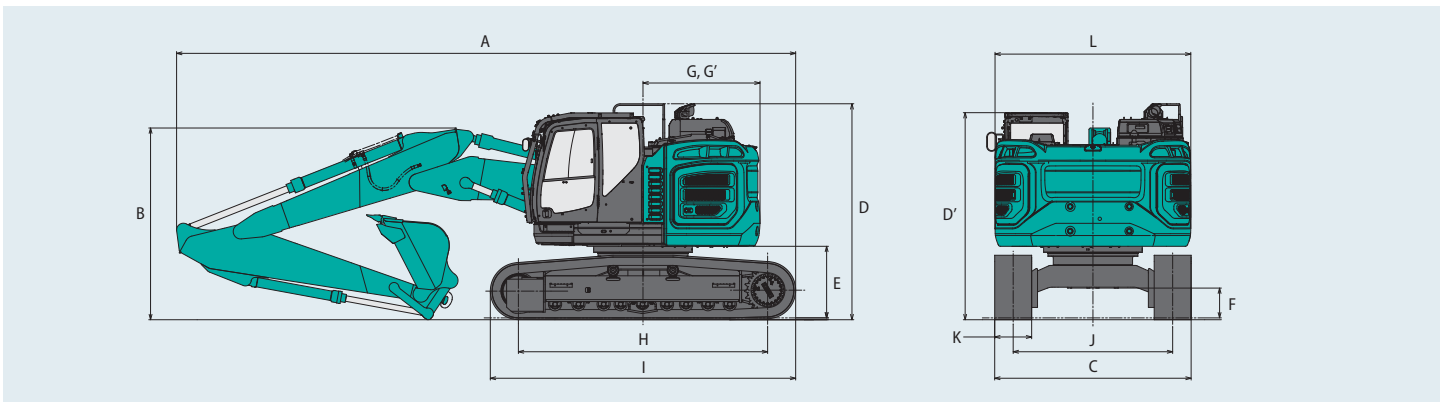

Operating weight & ground pressure

In standard trim, with 2 piece boom, 2.40 m arm, and 1.20 m³ ISO heaped bucket

Type of Grouser			Triple grouser		Double grouser	
Shoes	mm	600	700	800	850	600
Overall width of crawler	mm	3,190	3,290	3,390	3,440	3,190
Ground pressure	kPa	70	61	54	52	71
Operating weight	kg	37,500	38,300	38,800	39,000	38,000

In standard trim, with 2 piece boom, 3.10 m arm, and 1.20 m³ ISO heaped bucket

Type of Grouser			Triple grouser		Double grouser	
Shoes	mm	600	700	800	850	600
Overall width of crawler	mm	3,190	3,290	3,390	3,440	3,190
Ground pressure	kPa	71	62	55	52	71
Operating weight	kg	37,700	38,500	39,000	39,200	38,200

Lift Capacities

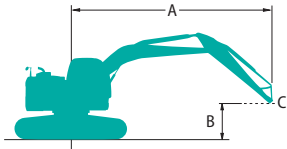

Rating over front



Rating over side or 360 degrees

A - Reach from swing centerline to arm top
B - Arm top height above/below ground
C - Lift point
Relief valve setting: 37.8 MPa {385 kgf/cm²}

SK380SRLC		2 Piece Boom		Arm: 2.40 m		Bucket: without		Counterweight: 9,000 kg		Shoe: 600 mm (Heavy Lift)				
A \ B		1.5 m		3.0 m		4.5 m		6.0 m		7.5 m		At Max. Reach		Radius
		Rating over front	Rating over side or 360 degrees	Rating over front	Rating over side or 360 degrees	Rating over front	Rating over side or 360 degrees	Rating over front	Rating over side or 360 degrees	Rating over front	Rating over side or 360 degrees	Rating over front	Rating over side or 360 degrees	
9.0 m	kg					*11,430	*11,430					*9,190	*9,190	5.15 m
7.5 m	kg					*11,020	*11,020	*9,830	8,510			*7,800	6,780	6.80 m
6.0 m	kg					*12,150	*12,150	*10,130	8,320	*9,090	5,730	*7,280	5,310	7.81 m
4.5 m	kg			*14,910	*14,910	*14,450	12,150	*11,040	7,870	9,260	5,580	*7,130	4,580	8.43 m
3.0 m	kg			*22,210	*22,210	*16,060	11,280	*12,080	7,350	8,990	5,340	7,090	4,220	8.74 m
1.5 m	kg			*27,900	21,720	*17,630	10,600	12,220	6,940	8,750	5,120	6,950	4,110	8.78 m
G.L.	kg	*26,800	*26,800	*26,870	21,160	*13,930	10,140	11,980	6,730	8,610	5,000	7,180	4,220	8.54 m
-1.5 m	kg					*14,710	10,230	*11,590	6,710	8,610	5,000	*7,800	4,630	8.02 m
-3.0 m	kg					*11,860	10,490	*9,420	6,880			*6,990	5,550	7.13 m
-4.5 m	kg			*19,290	*19,290							*4,880	*4,880	5.69 m

SK380SRLC		2 Piece Boom		Arm: 3.10 m		Bucket: without		Counterweight: 9,000 kg		Shoe: 600 mm (Heavy Lift)						
A \ B		1.5 m		3.0 m		4.5 m		6.0 m		7.5 m		9.0 m		At Max. Reach		Radius
		Rating over front	Rating over side or 360 degrees	Rating over front	Rating over side or 360 degrees	Rating over front	Rating over side or 360 degrees	Rating over front	Rating over side or 360 degrees	Rating over front	Rating over side or 360 degrees	Rating over front	Rating over side or 360 degrees			
9.0 m	kg							*6,130	*6,130					*4,890	*4,890	6.21 m
7.5 m	kg							*8,440	*8,440	*5,260	*5,260			*4,300	*4,300	7.63 m
6.0 m	kg					*9,280	*9,280	*9,250	8,490	*8,310	5,840			*4,050	*4,050	8.54 m
4.5 m	kg			*15,860	*15,860	*13,010	12,620	*10,240	8,030	*8,740	5,630	*5,020	4,120	*3,980	*3,980	9.11 m
3.0 m	kg			*24,000	22,660	*15,670	11,310	*11,430	7,460	9,020	5,350	6,770	4,020	*4,040	3,730	9.39 m
1.5 m	kg			*27,940	20,830	*16,980	10,380	12,270	6,970	8,730	5,090	6,640	3,890	*4,250	3,630	9.43 m
G.L.	kg			*24,510	20,530	*16,740	10,020	11,920	6,660	8,520	4,910	6,560	3,820	*4,620	3,700	9.21 m
-1.5 m	kg			*10,560	*10,560	*15,830	9,990	11,800	6,560	8,450	4,840			*5,280	3,990	8.73 m
-3.0 m	kg					*13,490	10,170	*10,470	6,640	*7,790	4,930			*6,500	4,630	7.92 m
-4.5 m	kg	*25,510	*25,510	*24,300	21,970	*14,930	10,830	*8,950	7,020					*5,650	*5,650	6.67 m

Note:

- Do not attempt to lift or hold any load that is greater than these lift capacities at their specified lift point radius and heights. Weight of all accessories must be deducted from the above lift capacities.
- Lift capacities are based on machine standing on level, firm, and uniform ground. User must make allowance for job conditions such as soft or uneven ground, out of level conditions, side loads, sudden stopping of loads, hazardous conditions, experience of personnel, etc.
- Bucket pin attachment point defined as lift point.
- The above lift capacities are in compliance with ISO 10567. They do not exceed 87% of hydraulic lift capacity or 75% of tipping load. Lift capacities marked with an asterisk (*) are limited by hydraulic capacity rather than tipping load.
- Operator should be fully acquainted with the Operator's and Maintenance Instructions before operating this machine. Rules for safe operation of equipment should be adhered to at all times.
- Lift capacities apply to only machine as originally manufactured and normally equipped by KOBELCO CONSTRUCTION MACHINERY CO., LTD.

Standard and Optional Equipment

● = Std ○ = Opt

Category	Description	SK380SRLC-7		
		Mono Boom / 2 Piece Boom		
ENGINE	ISUZU 6HK1 engine (EU Stage V compliant)	●		
	Exhaust DOC DPF SCR system	●		
	Alternator 24 V /90 A	●		
	Starter motor 24 V/5 kW	●		
	Batteries 2 x 12V (140Ah)	●		
	Fan suction type cooling system	●		
	Auto deceleration function	●		
	Auto Idle Stop (AIS)	●		
HYDRAULIC SYSTEM	3 work modes H, S, Eco	●		
	Power boost (37.8 MPa)	●		
	Heavy lift mode	●		
	Pressure release function	●		
	Independent travel function	●		
	Auto warm up system	●		
	Proportional Hand Control (for E & N&B piping)	●		
	Hydraulic oil VG32	●		
	Hydraulic oil VG46	○		
	Hydraulic oil VG68	○		
PIPING	E & N&B piping	●		
	QH piping	●		
CABIN	Air suspension seat with heating	●		
	10 inch colour monitor	●		
	LED door light	●		
	Air-conditioner	●		
	DAB+ radio (FM/AM & AUX & USB & Bluetooth* & hands free telephone)	●		
	Harness for cab four lights and cab yellow flasher	●		
	Parallel wiper	●		
	12V power outlet	●		
	Rain visor	○		
	Sun screen	●		
	Large footrest	●		
LIGHTS	LED work lights ; 2 on boom, 1 on upper frame, 2 on rear counterweight	●		
	LED work lights ; 2 on cab top front	○		
WORKING EQUIPMENT	Standard Boom (6.20 m)	●		
	2 Piece Boom	○		
	Standard arm (3.10 m)	●		
	Short arm (2.40 m)	○		
	Bucket link with lifting hook	●		
COUNTERWEIGHT	Standard C/W	●		
UNDERCARRIAGE	600 mm steel shoe	●		
	600 mm double grouser shoe	○		
	700 mm steel shoe	○		
	800 mm steel shoe	○		
	850 mm steel shoe	○		
	Track guide (one per side)	●		
	Additional track guides (two additional per side)	○		
	Lower frame guard	●		
	SAFETY	Engine emergency stop switch	●	
		Pump emergency mode (KPSS release switch)	●	
Emergency accel dial		●		
Emergency manual valve for lowering attachment		●		
Overload alarm		●		
Safety valve for boom & arm cylinder		●		
ROPS compliant cab (ISO 12117-2:2008)		●		
OPG Level II top guard (ISO 10262:1998)		●		
OPG Level II front guard (ISO 10262:1998)		○		
Eagle-eye view camera (Rear, Right, Left)		●		
Seatbelt indicator on display		●		
Travel alarm		○		
Emergency escape hammer		●		
OTHERS	Refueling pump	●		
	Harness for engine room light	●		
	RAL color	○		
	KOMEXS	●		

*The air conditioning system on this machine contains fluorinated greenhouse gas HFC-134a (GWP 1430). Quantity of gas 0.8 kg (CO2 equivalent 1.2 t).

Note: Bluetooth* is a registered trademark of the Bluetooth SIG Inc.

Note: This catalogue may contain attachments and optional equipment that are not available in your area. And it may contain photographs of machines with specifications that differ from those of machines sold in your areas. Please consult your nearest KOBELCO distributor for those items you require.

Specialist equipment is needed to use this machine in demolition work. Before using it please contact your KOBELCO dealer.

Due to our policy of continuous product improvements all designs and specifications are subject to change without advance notice.

Copyright by **KOBELCO CONSTRUCTION MACHINERY CO., LTD.** No part of this catalogue may be reproduced in any manner without notice.

KOBELCO CONSTRUCTION MACHINERY EUROPE B.V.

Veluwezoom 15
 1327 AE Almere
 The Netherlands
 www.kobelco-europe.com

Enquiries To: